

SOLAR POWERED AUTONOMOUS RAFT (SPAR)
FINAL YEAR RESEARCH PROJECT THESIS

Written by

Johnathon Borella

20916793

Bachelor of Science (Engineering Science, Management)



THE UNIVERSITY OF
WESTERN
AUSTRALIA

This thesis is presented for the degree of Master of Professional Engineering of
The University of Western Australia
School of Mechanical and Chemical Engineering

Academic Supervisor:

Professor Thomas Bräunl

School of Electrical, Electronic and Computer Engineering

Submitted: 28/05/2018

Word Count: 7381

THESIS DECLARATION

I, Johnathon Borella, certify that:

This thesis has been substantially accomplished during enrolment in the degree.

This thesis does not contain material which has been accepted for the award of any other degree or diploma in my name, in any university or other tertiary institution.

No part of this work will, in the future, be used in a submission in my name, for any other degree or diploma in any university or other tertiary institution without the prior approval of The University of Western Australia and where applicable, any partner institution responsible for the joint-award of this degree.

This thesis does not contain any material previously published or written by another person, except where due reference has been made in the text.

The work(s) are not in any way a violation or infringement of any copyright, trademark, patent, or other rights whatsoever of any person.

This thesis contains only sole-authored work, some of which has been published and/or prepared for publication under sole authorship.

Signature: 

Date: 28/05/2018

EXECUTIVE SUMMARY

The purpose of this research project was to send a solar-powered boat off the coast of Perth to Rottnest Island autonomously. This crossing is a proof of concept for the more significant problem to cross an ocean. An autonomous marine vessel has never completed an ocean crossing due to the sustainability of the boats. Relevant research has confirmed the suitability of solar panels as a form of sustainable power. Studies have also suggested painting the hull to avoid metal corrosion from seawater. Furthermore, the need for small prototype autonomous models to be tested extensively to fill the lack of current relevant research. This research project begun six months after the initial electrical system was designed and built. It takes the perspective of a mechanical engineer to create the physical systems of the SPAR. This report discusses in detail the relevant design considerations around a solar-powered autonomous raft (SPAR). The constructed multihull SPAR has undergone multiple tests in pools and the Swan River to prepare it for its maiden voyage to Rottnest Island. Overall the tests went productively with the majority of the time spent fine-tuning the internal electrical and software systems. Long range two-way communication is required to before the boat is ready for it's maiden voyage to Rottnest Island.

TABLE OF CONTENTS

SOLAR POWERED AUTONOMOUS RAFT (SPAR).....	1
FINAL YEAR RESEARCH PROJECT THESIS	1
THESIS DECLARATION.....	2
EXECUTIVE SUMMARY	3
TABLE OF CONTENTS.....	4
TABLE OF FIGURES	6
TABLE OF TABLES	7
TABLE OF GRAPHS.....	7
ACKNOWLEDGEMENTS	8
AUTHORSHIP DECLARATION	9
1. INTRODUCTION	10
1.1 BACKGROUND.....	10
1.2 PROBLEM STATEMENT	11
1.3 PROJECT AIM	11
2. LITERATURE REVIEW	12
2.1 SMALL AUTONOMOUS UNMANNED SURFACE VESSELS.....	12
2.2 CORROSION IN SEVERE ENVIRONMENTS.....	14
2.3 SOLAR POWER.....	14
2.4 AUTONOMOUS VEHICLES	15
2.5 STRENGTHS AND WEAKNESSES ANALYSIS.....	15
3. DESIGN PROCESS	16
3.1 APPROACH	16
3.2 REQUIREMENTS	16
3.3 CONSTRAINTS	18
3.4 QUALITY FUNCTION DEPLOYMENT (QFD)	18
4. FINAL DESIGN.....	19
4.1 BILL OF MATERIALS	19
3.5 ACCEPTANCE CRITERIA	20
4.2 PHYSICAL SYSTEM	21
4.3 ELECTRICAL SYSTEM.....	22
4.4 SOFTWARE SYSTEM	24
5. RESULTS.....	25
5.1 MODELLING	25
5.2 TESTING	25
6. DISCUSSION.....	26
6.1 EVALUATION OF FINAL DESIGN	26
6.2 DRAG ANALYSIS.....	26

6.3	WAVE ANALYSIS	27
6.4	RISK ANALYSIS	27
6.5	CORROSION	29
7.	CONCLUSION	31
8.	FURTHER INVESTIGATION	32
9.	REFERENCES	34
10.	APPENDICES	38
10.1	REQUIREMENTS OMITTED FROM MAIN REPORT	38
10.2	RESOURCES	38
10.2.1	Physical Hardware	38
10.2.2	Computer Software	39
10.2.3	Literature Database	39
10.2.4	Facilities	40
10.3	PERSONNEL	40
10.4	EXPERIMENTAL TESTING NOTES	41
10.5	BOUYANCY CALCULATIONS	50
10.6	STRUCTURAL INTEGRITY CALCULATIONS	51
10.7	CORROSION	52
10.8	WAVE ANALYSIS CONTINUED	53
10.9	THESIS RESEARCH PROJECT FUNDING	56
10.10	MAINTENANCE	57
10.11	USER GUIDE	58
10.12	SMALL MARINE VESSEL COMPARISON	60
10.13	SOLIDWORKS DRAWINGS	60
10.14	RISK MATRIX	60
10.15	RISK REGISTER	60
10.16	BILL OF MATERIALS	60
10.17	GANTT CHART	60
10.18	QUALITY FUNCTION DEPLOYMENT	60
10.19	ELECTRICAL BLOCK DIAGRAM	60

TABLE OF FIGURES

Figure 1: The SPAR Side View	10
Figure 2: The SPAR on the Swan River	11
Figure 3: The SPAR Tested at the UWA Swimming Pool	13
Figure 4: The SPAR Sitting Buoyantly in Pool Water	17
Figure 5: The SPAR On Ledge Prior to Testing	20
Figure 6: Front View of the SPAR while testing	21
Figure 7: External Switch.....	22
Figure 8: Plastic Coverings	23
Figure 9: Electrical Board (Hodge, 2017).....	23
Figure 10: Panorama Photo During Testing on the Swan River.....	24
Figure 11: Corrosion at Key Fixture	29
Figure 12: Thruster Fixed While Epoxy Sets.....	29
Figure 13: Final Coat of Spray Paint.....	30
Figure 14: Author Testing the SPAR on the Swan River	31
Figure 15: Sight Glass Designed and Build for Future Camera.....	33
Figure 16: First Swan River Test	43
Figure 17: APM User Interface.....	44
Figure 18: GPS Shift	44
Figure 19: Path Taken	45
Figure 20: Overview of Testing	46
Figure 21: Test 2	47
Figure 22: Test 3	47
Figure 23: Post Test Battery Check	48
Figure 24: Initial Test of the Day	49
Figure 25: Major Test Route	49
Figure 26: Ocean Testing Plan	50
Figure 27: Ocean Test Beach Closure.....	50
Figure 29: Galvanic Corrosion Visualisation.....	52
Figure 30: View of Complexity of Wires During Maintenance	57

TABLE OF TABLES

Table 1:	Results of Quality Function Deployment Analysis	18
Table 2:	Summary Bill of Materials	19
Table 3:	Overview of Electrical System. Sourced from (Hodge, 2017).....	22
Table 4:	Key Navigation Parameters	24
Table 5:	Physical Hardware	39
Table 6:	Computer Software.....	39
Table 7:	Literature Database	40
Table 8:	Facilities & Expertise Available	40
Table 9:	Project Team Members.....	41
Table 10:	Results of Solar Test.....	44
Table 11:	Buoyancy Calculations	51
Table 12:	Galvanic Corrosion Calculations.....	52
Table 13:	Relevant Types of Corrosion (Lui 2017).....	53
Table 14:	Relevant Types of Corrosion Protection (Lui 2017)	53
Table 15:	Wave Analysis Known Values	54
Table 16:	Wave Analysis Deep Water Values.....	54
Table 17:	Wave Analysis Breaking Calculations	55
Table 18:	Wave Analysis Predictions	55
Table 19:	Wave Analysis Forces Analysis	55

TABLE OF GRAPHS

Graph 1:	Drag Analysis of the SPAR	26
Graph 2:	Overall Plot of Wave Elevation.....	54

ACKNOWLEDGEMENTS

I would like to thank my academic supervisor, Professor Thomas Bräunl, for his help and guidance throughout the duration of my research project. I would also like to thank the members of the project team for their expertise and collaboration throughout the project. Finally, I would like to thank my friends and family for their support and encouragement over the course of the year.

AUTHORSHIP DECLARATION

I, Johnathon Borella, hereby declare that:

This document is my own unaided work. All direct or indirect sources used are acknowledged as references.

Signature: .. 

Date: 28/05/2018

1. INTRODUCTION

1.1 BACKGROUND

No solar powered autonomous marine vessel has traversed an entire ocean non-stop at the time this of this report. Autonomous vehicles are receiving greater media attention due to companies like Google, General Motors & Tesla making headway into the ‘self-driving’ car industry (Muoio, 2017). Drone Companies such as the Chinese company DJI Innovations are utilising part-autonomy to create smart drones that can proactively function in their environment, these are called ‘Intelligent Flight Modes’ (DJI, 2017). Newmont Mining in Western Australia cites the aspiration of a ‘people-less pit’ at their surface gold mines (Clough & Tan, 2010). Additionally, the European Union’s Maritime Unmanned Navigation through Intelligence in Networks (MUNIN) is researching the technical, economic and legal feasibility of un-crewed merchant vessels (Levander, 2017). Autonomous vehicles are therefore becoming commonplace within industry, recreation and education.

Two autonomous marine vehicle projects, “Solar Voyager” (Penny & Soon, 2017) and “Scout” (Subbaraman, 2013) have attempted to cross the Atlantic Ocean using only solar power. While “Seacharger” (McMillan, 2017), another autonomous marine vehicle, attempted to traverse the Pacific Ocean on solar power in 2016. Seacharger succeeded to cross from California to Hawaii then failed to make it to New Zealand. The designs of the vessels and reasons for failure are discussed further in this report. The Ocean is a severe environment, so the design of boats must involve consideration for high waves, salinity levels, large marine vessels and floating waste. The three ships described earlier lacked a reasonable functional test before they attempted to traverse their respective Oceans. Rottnest Island, based 18km from the coast of Perth, Western Australia. Crossing from Perth to Rottnest Island would have been the perfect test for any of these vessels to ensure the integrity of the mechanical, electrical and software systems before attempting an ocean crossing.



Figure 1: The SPAR Side View

1.2 PROBLEM STATEMENT

The problem of traversing an ocean is too significant to propose due to the resources, time and expertise required in such a long-term project. Perth is within reasonable proximity to Rottnest Island and so traversing to it acts as an ideal proof of concept for the scope of this project. The project commenced in February of 2017 by an electrical engineering thesis student. However, this component of the project begun in August 2017 and was started to give a mechanical engineering perspective to the project. The previous student finished his final report in November 2017, and the scope of this report developed from pure mechanical engineering to include electrical and software engineering. This project can be considered a marine systems engineering project and has involved further mechanical and electrical design, testing and software utilisation.

1.3 PROJECT AIM

To research, design, construct, test and implement a proof of concept low-cost solar powered autonomous marine vessel that will be able to autonomously travel from the coast of Perth to Rottnest Island.



Figure 2: The SPAR on the Swan River

2. LITERATURE REVIEW

2.1 SMALL AUTONOMOUS UNMANNED SURFACE VESSELS

There are a numerous small autonomous unmanned surface vessels (USV) constructed in the last decade. They use one or a mixture of solar, wind and wave energy for propulsion. A comparison table of ten small autonomous USVs, including the SPAR, are listed in Appendix 12. The SPAR was included after the literature review for increased understanding through this document; it is reference further in the report. Through comparison of the vessels, some trends can will be discussed and justified through literature. The vast majority of the ships analysed use fibreglass as the primary material for the hull. Aluminium and steel are the most common materials used in marine vessels (Håkansson, Johnson and Ringsberg, 2017). Fibreglass offers many advantages including corrosion resistance, significant weight reductions and easily moulded into hull forms (Håkansson, Johnson and Ringsberg, 2017). However, these advantages come at a substantial material and production cost. Fibreglass requires a hull mould to justify its shape; this mould is time-consuming and costly to manufacture. However, once the mould is made, it can be used multiple times without disrupting the design. Therefore, using fibreglass is suited for mass production of similar designs and offers many advantages if the initial investment can be overcome. Only three of the vessels are commercially used, they all use solar to power their electrical components and are reliant on either wind or wave for propulsion. Additionally, they happen to be the most robust and highly tested with each travelling over 5000 nautical miles. In particular, Wave Gilder, which uses wave energy as propulsion crossed the Pacific Ocean in 2012 only stopping at Hawaii (Lam, 2012). Using multiple forms of energy increases the total energy generated and allows the vessels to include a diverse range of electrical instrumentation. However, wave and wind power involve a complex mechanical system which in turn, increases the cost and expertise required to construct. Additionally, wave and wind power force the vessel to take specific routes, maintain velocity and other restrictions due to the variable nature of the energy.

All the vessels have a satellite connection, exploring further displayed that the majority used the company Iridium. The Iridium Satellite Network enables the largest area of coverage of any communication system in the marine environment. This feature is discussed in section 8 Further Investigation.

Of the research vessels, a number have been built to take part in a transatlantic race for autonomous boats, known as the Microtransat Challenge (Microtransat.org, 2018). The challenge started in early 2006 and had been running yearly since this the historical start of the small autonomous marine vessel frenzy. The competition has sailing and non-sailing divisions, which could be the reason why many of the vessels compared use wind power.

As of yet, according to their records, no autonomous boat has crossed the Atlantic Ocean (Microtransat.org, 2018). Every vessel used a single or monohull design with varying keels. Significantly, the Wave Glider uses a wire connection to the keel which also makes use of deeper wave currents as propulsion (Liquid Robotics, 2018). Additionally, the AutoNaut has little to no keel due to its radical horizontal hydrofoil design (AutoNaut USV, 2018). Using a monohull allows for simplicity in design, common designs in literature and a sizeable single-hull volume to utilise. However, multihulls don't require a keel for stability, have a more extensive 'deck' area and reduced risk because they have multiple buoyancy volumes (Davis and Holloway, 2007). Further research indicates that a majority of the monohull sailing boats are using a 'MaxiMOOP' hull designed by the U.S. Naval Academy and Aberystwyth University specifically for autonomous sailing (Miller et al., 2015). The MaxiMOOP is a 1.2 m long fibreglass monohull sailboat with a single sharp keel. It usually has one mast and at least one solar panel, but the vessel has multiple different configurations based on the user. As discussed earlier, a considerable cost of fibreglass hulls is the original mould and design. It is stated that as of June 2017 over 25 teams have used the MaxiMOOP design and hull mould, doing so would significantly reduce overall costs (Sailbot.org, 2017).

The research has shown that none of the vessels has object detection to prevent collisions which would seem a requirement for travelling across shipping lanes. Upon further investigation into maritime laws; the International Rules for Prevention of Collisions at Sea (COLREG, 2003) define a vessel as carrying passengers or cargo. It is understood that this doesn't class a small autonomous boat as a vessel and therefore exempts it from these rules. The ship compared that have failed did so due to impact or unknown causes. Having a video feed and in turn, object detection would have allowed this vessel greater intelligence and data analytics. Researching and comparing current small autonomous unmanned surface vessels allows for the foundation to meet the design requirements and produce a quality project.

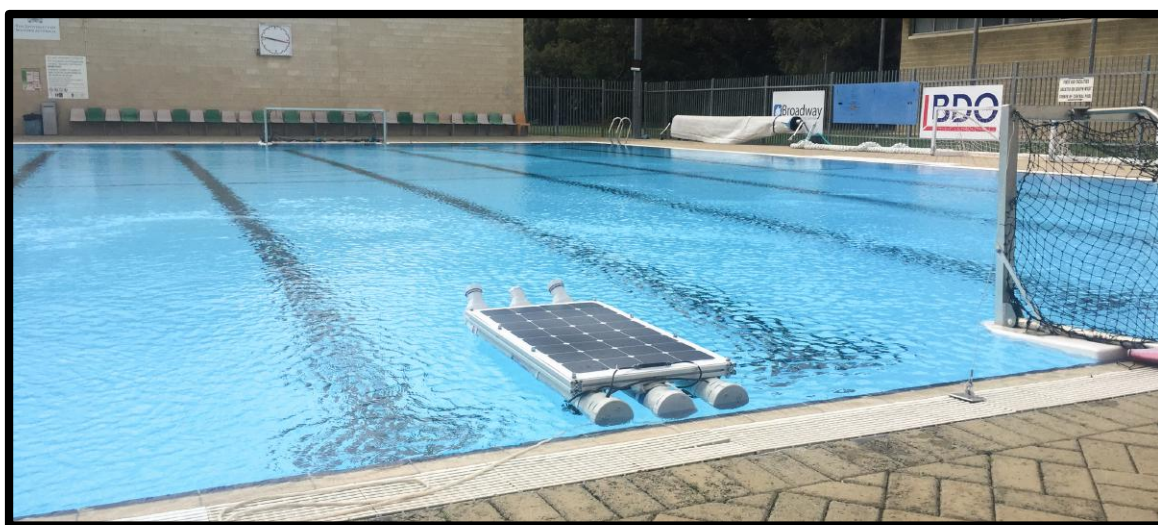

Figure 3: The SPAR Tested at the UWA Swimming Pool

2.2 CORROSION IN SEVERE ENVIRONMENTS

Corrosion is a naturally occurring phenomenon commonly defined as the deterioration of a material that results from a chemical or electrochemical reaction with its environment (Rudolf, 2008). The ocean is a notoriously corrosive environment and must be considered with care in marine design (Panosky, 2007). For example, although Aluminium has exceptional physical and chemical properties. There are multiple ways to protect materials from corrosion. The three most useful being the use of a sacrificial anode for cathodic protection, impressed current cathodic protection (ICCP) and surface covering. A sacrificial anode, for example, galvanised steel, is when a highly corrosive material - zinc - is used to corrode in place of the critical material – iron – to increase the lifespan of the structure (Mouanga, 2013). ICCP uses an external power supply to suppress the electron flow in a structure and thereby to reduce the corrosion rate to zero (Arendt, 2005). Surface covering is the use of paints and wraps to separate the material from the environment. From (Panosky, 2007) it is justified that colour continues to be the primary mechanism to prevent metal corrosion. Merely removing the corrosive metal from the environment can, with proper maintenance, reduce the corrosion rate down to zero.

2.3 SOLAR POWER

Solar Panels have no moving parts, and the only significant maintenance cost comes from cleaning the panels. Due to these factors, solar panels are incredibly useful for functions that occur over an extended period of time in the open environment. Solar panels can produce a consistent base load power for the duration of exposure to sunlight, this enables strong assumptions about the efficiency of a specific solar panel, and when a stable work period can occur (Rodríguez, 2005). Additionally, solar panels have been developed over time to become lighter and are now made out of plastics instead of metals, which negates corrosion considerations; as well as weight issues (Rodríguez, 2005). Finally, the most valuable function of a solar panel is the ability of the batteries to charge during the daytime, enabling solar energy to be used at night when the solar panels are not receiving power (Garcia-Cordova, 2013). These functions allow solar panels to be a robust, long-term solution for energy harvesting. In an investigation by (Gorter, 2011), fifteen photovoltaic polymers for marine applications were compared as marine environments offer additional benefits to solar energy is utilised. Potential benefits cited in the study include high reflection levels off the water, an unobstructed sun enabling more extended use hours and self-cleaning using wave wash. (Gorter, 2011) Concludes that if cost is an important factor, then epoxy is the best all-around polymer with excellent UV resistance and tensile strength. Through extensive innovation, it costs under \$1 USD to produce one Watt of electricity in 2017 (Solar Choice, 2017). Solar power is a fantastic source of energy for autonomous vehicles as it requires very little maintenance due to a lack of moving parts.

2.4 AUTONOMOUS VEHICLES

Autonomous vehicles are becoming increasingly prominent across industries, due to their utility in long-term functions and the advancement of autonomous technology such as self-driving cars. The economic viability of autonomous vehicles was argued by (Kretschman, 2017). The article conveys specifically that autonomous ships are a vital element of a competitive and sustainable shipping future. The article claims that costs are significantly reduced by crew reduction, fewer stops into port, more space for commercial goods and less fuel spent on internal needs (Kretschman, 2017). A number of Unmanned Surface Vehicles (USV's) have been compared and detailed by (Caccia, 2007) used in commercial industries, scientific studies and military applications. The paper discusses the patterns that occur from their research including hull shape, power supply, cost development and goal discussion. In the document, it is outlined that a catamaran shaped vessel or multihull boat optimises mounting and loading capacity due to its minimisation of movement from waves (Caccia, 2007). However, it also discusses that a monohull vessel can carry a more considerable amount of fuel and is favoured in military application. The paper goes on to examine the use of long-term power sources and reducing environmental impacts from fuel pollutants (Caccia, 2007). It is highly essential to have a sustainable and reliable power source when testing a prototype as multiple destructive and unforeseeable events can occur. (Caccia, 2007) Considers that low-cost prototypes are highly valuable, as greater research is needed; additionally, that "conversion kits" are desirable to convert existing vessels into autonomous ones. The discussion demonstrates that a low-cost solar power multihull marine vessel is a good option for prototyping.

2.5 STRENGTHS AND WEAKNESSES ANALYSIS

The literature review used diverse sources of information with blog posts to peer-reviewed journal articles and indicated that the degree to which they should be relied on. Unfortunately, there was a lack of relevant peer-reviewed journal articles due to the current subject matter. The literature review fills the lack of research with background into the multiple factors that go into an involved marine vessel from hobbyists, open source platforms and commercial developments. There is a lack of diversity in some designs due to the high initial costs involved with manufacturing, so errors haven't been designed out over time. On the other hand, the literature review has shown some radical designs coming out of commercial industries and the justification for this research project. Furthermore, it has conveyed an ideal hull design, material and energy generation selection to base the final design on.

3. DESIGN PROCESS

3.1 APPROACH

The approach of this report can be most easily viewed by breaking down the aim into four major sections. The parts are chronological and are dependant on the previous tasks completion.

Section 1 Design & construct a floating vessel which meets the acceptance criteria

The SPAR must be based on the project requirements and meet the acceptance criteria to be viewed as successful.

Section 2 Support the other team member's systems integration with the designed SPAR

The project has a multidisciplinary team, and the SPAR has to integrate the multiple engineering systems into a complete system.

Section 3 Implement and test a long-range communication system

The SPAR needs to be equipped with multiple communication systems that will enable constant two-way communication with the land during voyages.

Section 4 Send the SPAR from the coast of Perth to Rottnest Island

The ultimate goal of the project is to send the SPAR to Rottnest Island; all previous sections must be ratified before this can be accomplished.

3.2 REQUIREMENTS

The five significant requirements are shown below, the full set of requirements are shown in Appendix 1 and also in the quality function deployment detailed in Appendix 18. The requirements have a direct effect on the final design of the SPAR.

Requirement 1 Integrity and sustainability of the SPAR

An ocean with a severe environment to design within due to the random forces, corrosion and great total area. Therefore, the SPAR is required to resist random impacts, shear and bending forces (pitching, yawing and rolling) from waves and ocean debris. Additionally, the SPAR needs corrosion considerations to reduce continuous damage to the integrity of joints and fixtures. Furthermore, the SPAR must be able to sustain itself for the duration of the voyage. Whether that sustainment is through ongoing communication to land, constant movement or relying on currents for propulsion.

Requirement 2 Buoyancy and distribution of weight

The SPAR need to be sufficiently buoyant to offset the importance of the components. Additionally, the elements need to be arranged thoughtfully to consider weight distribution. These two parts of the requirement are essential to reduce the overall drag of the SPAR, wasted energy in correcting the navigation course and effect of wave/ocean forces.

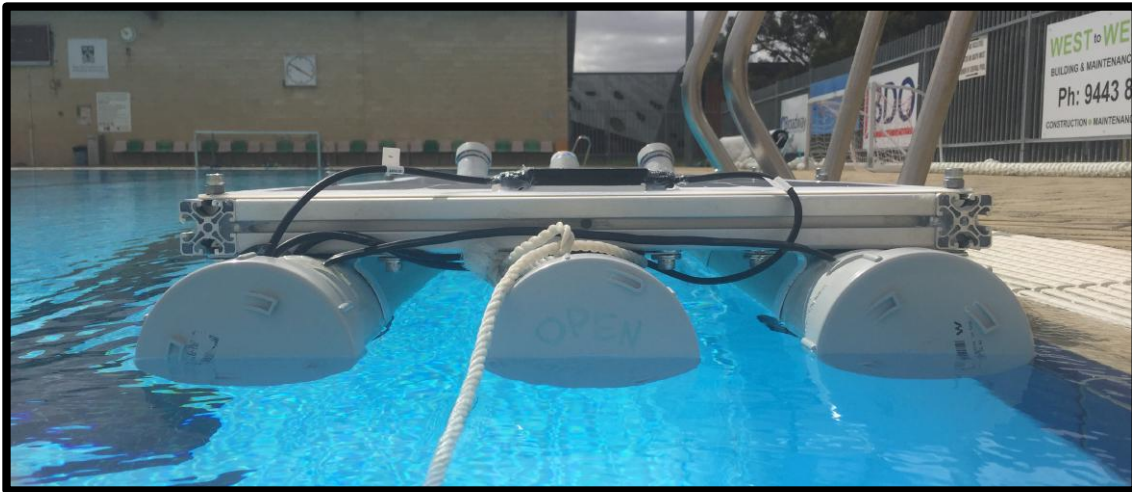

Figure 4: The SPAR Sitting Buoyantly in Pool Water

Requirement 3 Cost and feasibility

The University of Western Australia allocates \$500 per student for their research project according to Appendix 9 Therefore, the total cost for the SPAR needed to be under \$1000. A significant amount of the parts was bought previously, so the allowable for this report design was \$500. Additionally, it was necessary for the components of the SPAR to be easily sourced and replicated. This was in case something was damaged, or future students working on the SPAR wanted to reproduce it.

Requirement 4 Integration with the other engineering systems

As discussed previously, a large part of the design had already been completed to my commencement of the project. Therefore, the model proposed had to work around these engineering characteristics and constraints.

Requirement 5 Testing

The SPAR had to be simple to setup and test, with an easily repeatable method that would give similar results in different environments. This condition links in with other requirements but is necessary to mention as it must be established through repetitive physical testing.

3.3 CONSTRAINTS

The constraints are significant factors that influenced the outcome of the final design and project.

Constraint 1 Previous design work

The thrusters and the majority of the electrical components, including the solar panel, were bought with the other students funding, before the commencement of the project. They are detailed in the bill of materials in section 4.1 and Appendix 16.

Constraint 2 Aluminium frame material given

During the frame design phase, Critical Room Solutions based in Forrestfield Western Australia sponsored the project and gave the aluminium item beam extrusions, fixtures and bolts free of charge.

Constraint 3 Time allocated to project

Due to the professional practicum requirements within the Master of Professional Engineering, the project progress was reduced during November, December, January and February.

3.4 QUALITY FUNCTION DEPLOYMENT (QFD)

The Quality function deployment is an engineering design tool to justify the link between the requirements of the design and engineering characteristics of parts used. It is shown in Appendix 18 and the results are shown in Table 1 below. This tool displays that the reliability, weight and dimensions of the SPAR are the most important characteristics when planning to the design requirements. Additionally, that test cycle, power and time to set up are the least important. These results seem reasonable and inform the acceptance criteria of the final design.

Table 1: Results of Quality Function Deployment Analysis

Engineering Characteristics Results			
1	Reliability (%)	6	Cost (AU\$)
2	Weight (kg)	7	Velocity (m/s)
3	Dimensions (m)	8	Test cycle (min)
4	Expected life (yr.)	9	Power (KW)
5	Testing distance (m)	10	Time to set up (min)

4. FINAL DESIGN

4.1 BILL OF MATERIALS

The bill of materials is discussed here but due to its size it is shown in Appendix 16, and it is broken into three parts:

1. Purchased Materials Semester 1
2. Purchased Materials Semester 2
3. Electronic and other components

The three parts are divided to enable acute discussion of cost as the project is multidisciplinary and the different systems require their budgets. A summary of the Bill of Materials is shown below in Table 1. The current cost is \$1m054.02, as two thesis students were working on the project with a budget each of \$500.00. The electrical parts need to be considered in the total cost scheme but are not the focus of this report. The most significant costs include the solar panel and motors due to the complexity and requirements of the parts. The project saved money on the frame as a local company fabricated it at no cost. The semester two prices include paint, pipe materials, lights and maintenance parts. Unfortunately, it was discovered that the \$500.00 allocation was supposed to be split fifty-fifty into materials and labour hire, the specific reference is shown in Appendix 9. There is the project team completed an ongoing discussion at the time of this report as the labour of the SPAR. With the expectation that saved costs on employment could be used for materials. The costs went over budget due to the design and construction of the image processing sight glass discussed in section 8 further investigation. The sight glass wasn't in the original scope of the project but has been developed as the basis for future development.

Table 2: Summary Bill of Materials

BILL OF MATERIALS		
DESCRIPTION	Number of Components	COST (AUD)
Purchased Materials Semester 1	27	\$ 553.84
Purchased Materials Semester 2	17	\$ 179.68
Electronic & Other Components	10	\$ 320.5
Total	54	\$1054.02

3.5 ACCEPTANCE CRITERIA

The acceptance criteria are linked to the aims, requirements and engineering characteristic of the project, they have been made into questions to increase the sensitivity when assessing them.

Acceptance Criterion 1 Does it float?

This criterion involved the weight and dimension engineering characteristics. It has been proven to be true based on testing and buoyancy calculations.

Acceptance Criterion 2 Does it fit all the electrical components?

This criterion involved the dimension, time to set up, power and reliability engineering characteristics. It is a close fit to include all the electrical components in the 100 mm PVC pipe and involved a few improvements to ensure this criterion stays true into the future.



Figure 5: The SPAR On Ledge Prior to Testing

Acceptance Criterion 3 Is it to the budget?

This criterion involved the cost engineering characteristic. It was thought to be true, but with new information regarding the requirement for 50% of the budget to be spent on labour hire, it may prove to be false, as per Appendix 9. If this is not the case, then the project is under budget shown in section 4.1.

Acceptance Criterion 4 Will it sustain testing and a voyage to Rottnest Island?

This criterion involved the reliability, testing distance, velocity, test cycle, power and expected life engineering characteristics. It is the culmination of the years' project. Unfortunately, while it may be possible that the criterion is valid, without long-range communication, it can not be tested. The criterion can be justified to be close because of testing on the Swan River and off the coast.

4.2 PHYSICAL SYSTEM

The SPAR is a PVC multihull marine vessel with an aluminium frame, steel fixtures and some 3D printed parts. The issues with having multiple metals in the severely corrosive environment is discussed further in this report. All the parts except for the aluminium frame can be purchased from local hardware stores. This difference is because the structure is a very robust patented, anodised extrusion that was given to the project team for free by a local manufacturer. If it is damaged in the future, it can be switched out for a steel frame with only a few design changes. The physical system revolved mostly around the dimensions of the solar panel shown in the technical drawings, Appendix 13. These dimensions determined the frame size and in turn the number of PVC pipes needed. The saddles are designed to attach PVC pipes to walls as downpipes, they were cold worked and adjusted to fit the needs of the project. The front hull angle utilises 45-degree bends and reducer parts to create the high profile, shown in Figure 6 below. The design team decided the front of the PVC pipes needed to be accessed for future improvements so a screw cap was made up that allows access while not letting water in to the internal pipe. The rear of the PVC pipe uses an end screw cap with a rubber O-ring, these were well tested for leaks before putting electrical equipment inside. The SPAR has a velocity between 1-2 m/s while experimenting on the Swan River; it was designed for 1.3 m/s (Hodge, 2017) and so is within a reasonable range. Current testing is focusing on making the propulsion system efficient to gain a more accurate estimate of the SPAR's velocity. Through trial and maintenance, some smaller revisions have been made to the overall physical design. 3D printed parts are notoriously porous and some wear and tear was noticed; so they have been filled with epoxy resin and have been robust since. A solar garden light has been retrofitted onto a flagpole and can be attached to the SPAR for overnight voyages. This is used for the safety of the SPAR and to meet Maritime Standards (COLREG, 2003). Metallic fixtures that have corroded have been switched with galvanic elements and covered with paint. This is discussed further in section 6.2 along with how silicon was used to reduce residual water build-up.



Figure 6: Front View of the SPAR while testing

4.3 ELECTRICAL SYSTEM

The electrical system is designed by the other project team thesis student John Hodge, refer to his thesis report for additional information to this report (Hodge, 2017). The electrical block diagram is shown in Appendix 19; it was drafted by John Hodge and finalised for this report. It is currently at the submission of this report on the 28th of May 2018. Additionally, the electrical component bill of materials is shown in Appendix 16. An overview of the electrical system is shown below, the thrusters have a massive potential propulsion capacity and as discussed in testing, were able to drag a person on a stand-up paddleboard. This significant power draw could be the reason for voltage warnings during the trial. Shown in Table 3, the solar panel could support up to six additional batteries. This project report details the following improvements to the established electrical system:

Table 3: Overview of Electrical System. Sourced from (Hodge, 2017)

Solar Panel Power Generation	400 Wh/day
4x Battery Storage Capabilities	158.4 Wh
2x Allowable Thruster Power Draw	16.62 W
2x Thruster Max Possible Power Draw	260 W

Improvement 1 Including an external switch

The external switch wasn't initially considered to be vital, but the 7th Test in Appendix 4 displayed its importance. It is connected to the Arducopter switch so the boat's solar regulator can be turned on without the controller and electrical equipment turned on. Having an external switch has increased the amount of testing possible. Additionally, the sustainability of the electrical components increased because the electrical board doesn't need to be removed.



Figure 7: External Switch

Improvement 2 Covering sensitive parts with plastic to reduce

The significant portion of the damage occurring to the electrical board occurs when the board is loaded into the PVC pipes. This was shown to be an unavoidable issue during the 5th test and needed to be remedied before any significant testing was conducted. A few solutions were considered, but due to the dimension restrictions, a plastic covering from a water bottle was used. This gave the wiring convex protection that fits well with the PVC pipes. There has been no significant damage since the covers were implemented. Additionally, the plastic covers can be unscrewed when work needs to be done on the electrical components underneath.

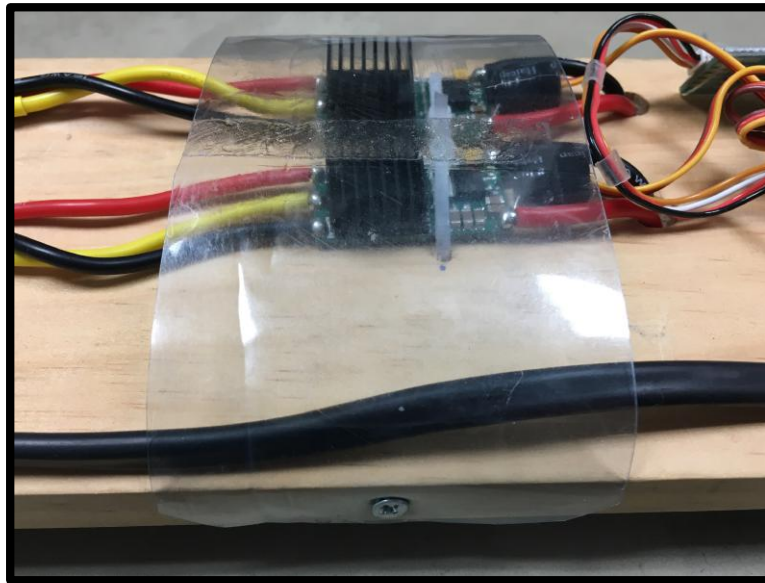

Figure 8: Plastic Coverings

Improvement 3 Wire Management

The motor controller connections were unnecessarily large, so smaller plugs were researched and bought. Furthermore, multiple wires were worn out and required resoldering, adjusting and splicing. The solution has reduced the number of cables being dislodged and the overall sustainability of the electrical system.

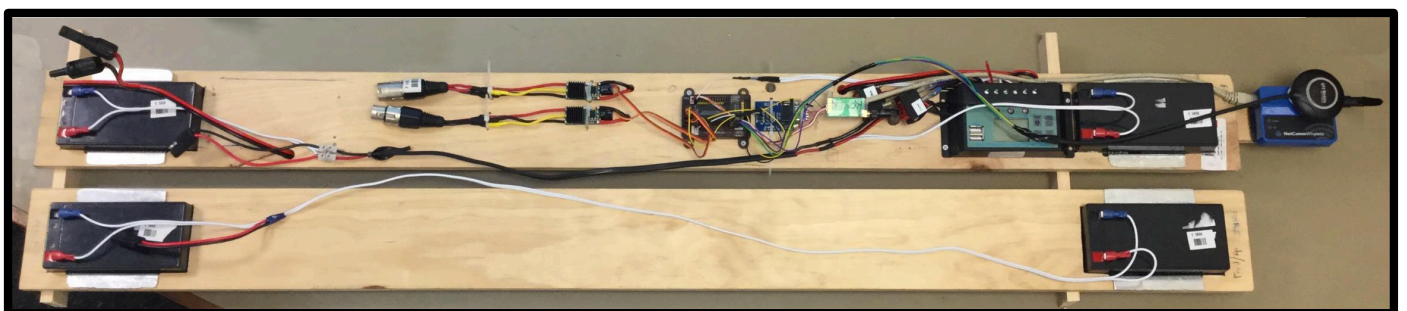

Figure 9: Electrical Board (Hodge, 2017)

4.4 SOFTWARE SYSTEM

The SPAR uses APM Planner 2.0 to read and write waypoints through a radio connection. Which, enables the SPAR to cycle through the desired path autonomously. This system was established by the other project team thesis student John Hodge, refer to his thesis report for additional information to this report (Hodge, 2017). Testing has focused on increasing the efficiency of this system and is discussed in section 5.2, but the project report details the following improvements to the software system:

Improvement 1 Adjustable navigation autopilot parameters

The navigation parameters control the SPAR's processes as it cycles through the waypoints, there are some additional ones to the focus of this report, and the full list can be found online (ArduPilot.org, 2016). It is important to note that the SPAR needs to be connected to APM Planner to view and change the navigation parameters, refer to the user manual in Appendix 11. The following parameters were adjusted through testing to create a smoother turn; the results are shown in section 5.2.

Table 4: Key Navigation Parameters

Parameter Name	Before	After	Description
STEER2SRV_P	1.8	5.0	The turning circle (Diameter) is for the SPAR
NAVL1_PERIOD	10	40	Aggressiveness of turning, larger tends to smoother turns
NAVL1_DAMPING	0.75	.70	Control damping to reduce overshoot
SPEED_TURN_GAIN	50	100	To not slow down at all in turns set this to 100

Improvement 2 Data Logging of crucial system outputs

Being able to understand and communicate the data logged is an integral part of this project. Many options were considered, but the use of APM Planner's additional graphing software was the one chosen. An 'apmlog' is created by the software after each test and can be loaded into the APM Planner for analysis; this enables the project team to understand where the most essential issues are and what can be improved.



Figure 10: Panorama Photo During Testing on the Swan River

5. RESULTS

5.1 MODELLING

The full design drawings don't include specific drawings of parts because they are bought, not manufactured. The Modelling was done in the software Solidworks and is shown as technical drawings in Appendix 13. Refer to the Bill of Materials in Appendix 16 for a full list of parts used.

5.2 TESTING

Multiple tests have been performed with the full discussion and analysis shown in Appendix 4; it is highly recommended to read these. The tests can be broken into two types:

Type 1 Function Testing

The first seven tests can be considered function testing; they test various parts of the SPAR. The pipe seal testing was used to check the PVC pipes before any electrical equipment was put in. This was reviews again along with a buoyancy test, ensuring the pressure wouldn't negatively affect the pipe seals. Many water tests were conducted to evaluate the different systems on the SPAR and one land test to check the solar and GPS capabilities of the SPAR. Of the water function tests, the majority were conducted at the University of Western Australia's pool. This was to reduce the risk of the SPAR getting outside of the manageable range. The tests progressed to the swan river, and once the SPAR was considered reliable, the testing was able to move onto the second type.

Type 2 Efficiency Testing

The efficiency testing occurred after the SPAR had undergone enough tests aimed at specific areas of the system. The main aim of the efficiency testing was to shift the SPAR's capabilities from the Swan River to the Ocean. This involves a lot of trust with the SPAR and preparing the correct measures if something did go wrong. An inflatable stand-up paddleboard was purchased at a personal cost to enable solo testing, as both could now fit in one car. A new location was also chosen on the swan river, where the parking lot was immediately next to the water. This lets the tester lock the car with the laptop inside, and go out on the water with the SPAR while still maintaining a connection. These tests also focused on finding unknown issues, such as the voltage drop occurring in analysis ten after an extended period. This issue is thought to be due to the immense power consumption potential of the thrusters which needs further calibration. The highlight of the testing was sending the SPAR on a long voyage on the Swan River to try and drain the batteries, the SPAR performed well and made it all the way. Through the trial, it can be seen that the SPAR is effectively progressing towards voyaging to Rottnest Island.

6. DISCUSSION

6.1 EVALUATION OF FINAL DESIGN

The design of the SPAR is born out of the requirements of the project. It is considered to be a good solution due to meeting the acceptance criteria shown in section 4.1 and being modular enough that plans can develop the robust design. The main disadvantages include being unable to right itself if the SPAR capsizes, no object detection to stop collisions and an underutilisation of the generated solar power. These issues are solvable with further resources and expertise.

6.2 DRAG ANALYSIS

A wave and viscosity drag force analysis has been conducted on the SPAR and shown in graph one below. The study shows that as the velocity increases, the drag increases. This doesn't take into account the "planar effect" where a boat skips along the water, significantly decreasing its drag. It isn't believed that the SPAR can build up enough velocity to produce this effect. What the analysis does display is that the drag from ploughing through waves will significantly increase as the velocity increases. The forces acting aren't enough to do lasting damage to the integrity of the SPAR. The SPAR has been designed to travel at around 1.3 m/s which produces a total drag of under 20 N.

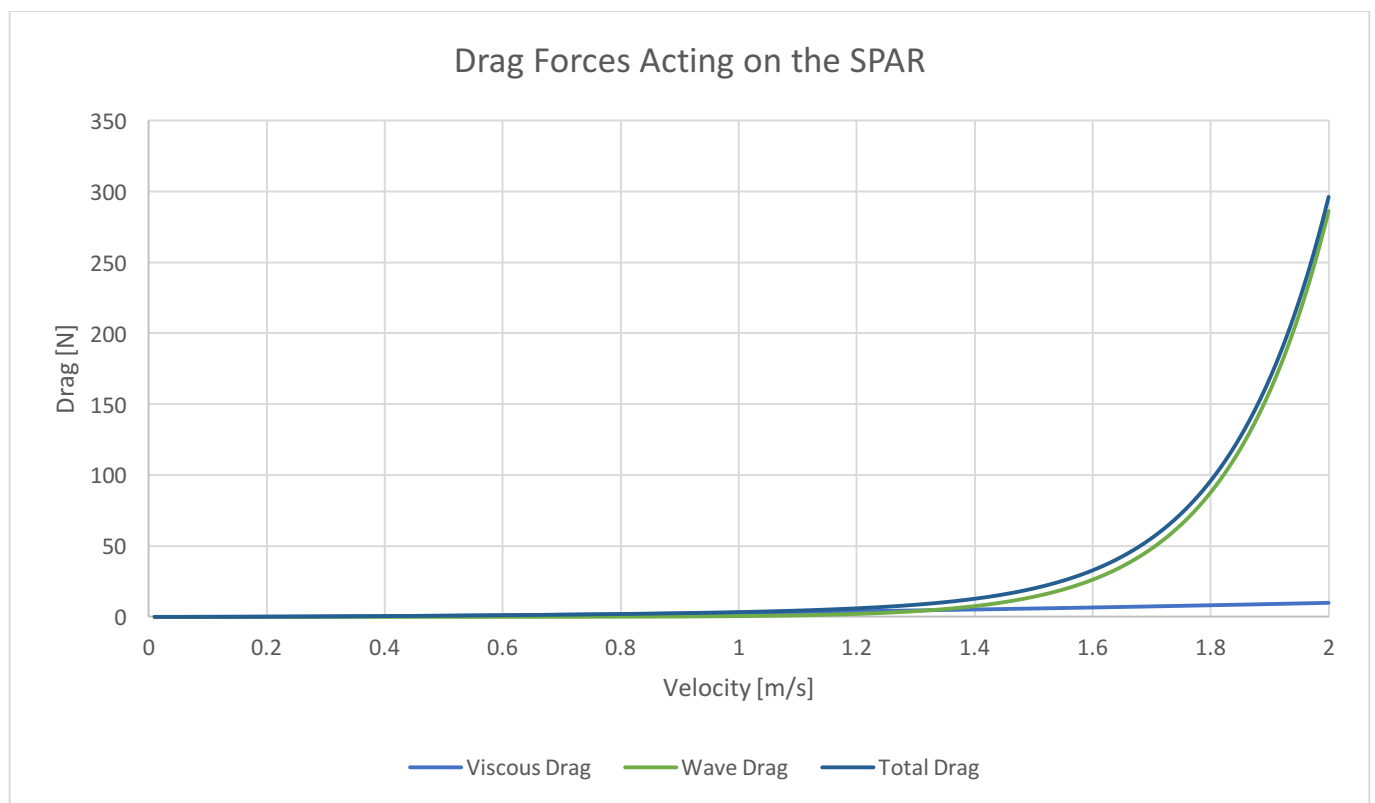

Graph 1: Drag Analysis of the SPAR

6.3 WAVE ANALYSIS

It is essential to understand and discuss the environment the SPAR is voyaging on to justify the final design. The specific importance of this study is regarding impact forces and predicting the size of wave required to capsize it. The significant wave height off the coast of Western Australia was found to be 2.696 m and wave period 5.833 s. The significant wave height and wave period allow essential values to be estimated.

If we consider the SPAR to be mostly voyaging in deep water, then the length of the wave can be calculated as 53.122 m and velocity as 9.107 m/s. This is a fast wave, but more importantly, the breaking wave height can be estimated as 7.588 m. With this value, it is possible to predict the number of days required to pass before the SPAR comes in contact with deep water breaking wave. It was found that over 515 days are needed for a surge higher than 7.588 m to occur. This value is only an estimate and is used to show that it is highly unlikely for the SPAR to be capsized by a breaking wave offshore.

Calculating the forces acting on the SPAR using the wave data gives a reasonable result using the full diameter of the 100 mm pipe. However, it is essential to question the validity of the effect due to an oversimplification of the study. The drag, lift and inline max forces calculated are 129.799 N/m, 108.166 N/m and 320.804 N/m. They have been considered to act perpendicular to the pipes, as tipping forces. This was because it would seem more comfortable for the SPAR to capsize by rolling on its side rather than over its back or front. The overall effects on the SPAR are very hard to calculate and require the use of modelling software to correctly understand. To offset these uncertainties, the SPAR has been designed with safety factors and reinforced at vital stress points such as the frame/saddle fixture.

6.4 RISK ANALYSIS

The risk register was started before the proposal, it is a live document and has been updated and attached in Appendix 15. The principal risks have been assessed and mitigated through implementing different solutions. The following three key risks are the ones believed to be most important to the outcomes of the SPAR.

Risk 1 Lost Connection between the Server and SPAR

A loss of connection can occur for many reasons such as the SPAR going outside of range like test 7 in Appendix 11.6 which was a user error where the home coordinate wasn't submitted to the SPAR. The main issue occurred because the SPAR was unable to be turned off from the outside. This was rectified by adding an IP67 waterproof switch to the front of the boat.

On longer voyages where the SPAR will be connected via 3G or satellite physically turning it off becomes harder. Instead, if the journey is planned well in advance, the SPAR should continue without a connection so it can be picked up at the end. Additionally, once setup it will attempt to reconnect to the server through the same ports. If the connection is completely lost for an extended period and the SPAR is considered lost it can be assumed that it has capsized or water has gotten inside the pipes. The capsizing issue is discussed further in Risk 2 below.

Risk 2 The SPAR becomes capsized

It is unlikely that the SPAR will become capsized, but if it does, it is highly improbable that it will be able to right itself. This risk can be mitigated by estimating the environments that could cause the SPAR to capsize and keeping it out of them. It is possible to proactively attach contact details to the SPAR if a person comes across it. Additionally, alerting the local marine authorities to the failure would increase the chances of recovering it and learning from it.

Risk 3 Scope of Project Shifts

As the project develops the scope of the project could shift into territories where the current team's expertise is limited. This could slow the project or halt it altogether. The strategy to implement is communicating the plan to a broader audience thus enabling input from a more critical skill set. University Clubs are ideal environments for getting access to these levels of expertise with the limited resources of the project. Additionally, a student can start a thesis each semester so a new team member could join roughly every six months. This would allow the team to intentionally change the scope as the project develops, turning risk into an opportunity.

The risk matrix for a catastrophic failure of the SPAR in Appendix 14 shows that the overall risk is low. This is because the potential for it to occur is unlikely during the lifecycle of the SPAR. Additionally, while other small marine vessels have failed the impact was low, and they can be recovered. The environmental effect is quite low with the worst result being a battery leakage. However, this would be contained by the PVC pipes, and the SPAR could be recovered from its connection to the server. The overall cost of the SPAR is under \$1,000 dollars, and repair costs would be a fraction of that sum. Failure wouldn't necessarily cause a stain on personal, professional and institutional reputations as the project is a proof of concept. Nevertheless, any failure will and should be cleaned up by removing the SPAR from the ocean. The only realist risk to human life the SPAR could cause is if it runs into their head while they are swimming in the water. It would at worst cause a small bruise and shock. In summary, the probability of a catastrophic failure is low, and the likelihood of it causing significant repercussions is even lower.

6.5 CORROSION

Many types of corrosion could occur in the different metal parts of the SPAR. Carbon steel, aluminium and galvanic steel are all used on the SPAR. When considering the materials used and the environment, the relevant types of corrosion are shown in Table 13. The corrosion analysis focused on the vital area of galvanic corrosion to determine the electrical difference between using mixed metals in the ocean environment. The results of the calculations are shown in Table 12.

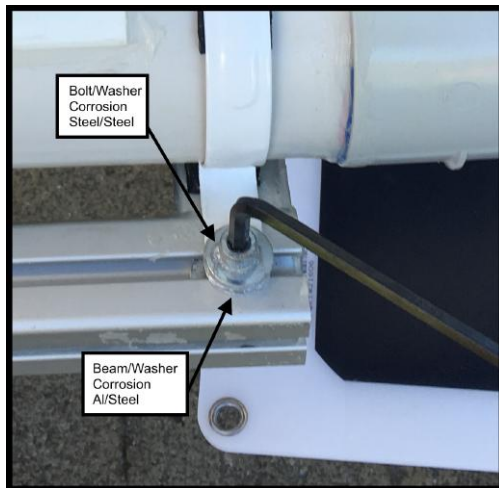

Figure 11: Corrosion at Key Fixture



Figure 12: Thruster Fixed While Epoxy Sets

In hindsight only considering galvanic corrosion in the design phase and underestimating the power of corrosion was a mistake. Shown in Figure 11 above a significant amount of corrosion at a critical fixture has occurred during the Swan River Testing. This is most likely from oxidation, happening while the SPAR was out of water between testing. This is a significant issue because the ocean environment creates ideal oxidation conditions due to the cyclic nature of waves. The wetting and drying of the metals will very quickly corrode the joints. The issue is coupled with corrosion fatigue from the stressors involved with wave forces and could cause a catastrophic hazard. Pitting uniform and crevice corrosion was found at smaller levels when maintenance was conducted on the SPAR, discussed further in Appendix 10.

There are many ways to slow or stop corrosion; the relevant ones are shown in Table 14. The surface covering, in the form of spray painting has been chosen as the ideal solution because cheap, easy to source parts and quick to implement compared to the other options. All purpose primer spray paint was used first because of the different materials used due to there being small amounts of corrosion sporadically on the parts. Then once that was dry a white epoxy enamel spray paint was applied. Each section was sprayed twice with each can because spray paint doesn't touch 100% of a surface. This was a, and realistically the pieces will have 2-4 protective coats. Figure 13 shows a number of the elements after the white coat; the primer coat is shown as the dark grey residue on the sheet. Small missed spots were touched up once the SPAR was reassembled. The spray paint has a rating for five years but due to the hard environment that the SPAR is working within it should be checked every six months.



Figure 13: Final Coat of Spray Paint

7. CONCLUSION

The aim of this thesis was to research, design, construct, test and implement a proof of concept low-cost solar powered autonomous marine vessel that will be able to autonomously travel from the coast of Perth to Rottnest Island. The SPAR has been designed to the requirements of the project and met the acceptance criteria. Varying studies into such areas as corrosion, risk and waves have been conducted to justify the final design. Shown through testing on in pools, the Swan River and the ocean the SPAR is physically capable of making the voyage but it is still lacking the long range communication system that is vital for a voyage of this length. Further study into image processing has been begun with the construction of a sight glass that sits on the front of the SPAR.



Figure 14: Author Testing the SPAR on the Swan River

8. FURTHER INVESTIGATION

Development 1 Long-range communication system

The options are to either use a sim card with 3/4G or a satellite modem. A 3G modem has already been purchased, and steps have been made to set up a communication system. This would be effective for the trip to Rottneest Island but would run into issues if the SPAR went further due to the small range of the 3G Network. Using a satellite modem would significantly increase the potential scope of the SPAR but would cost around \$300 for an Iridium Modem, and approximately \$0.30 for each data packet sent (Rock7mobile.com, 2018). It would be a good solution if the project develops further but may be outside the budget for the near future.

Development 2 Battery Capacity

As discussed in section 4.3 there is the potential to increase the number of batteries on the SPAR by up to six. This would substantially increase its longevity and range but comes at a buoyancy cost. Fortunately, there is room for a fourth PVC pipe on the frame, and the SPAR sits well in the water already. Given the number of PVC pipes are restricted to four without a redesign, it could be assumed that with two batteries per PVC pipe, the SPAR could take on an additional four batteries.

Development 3 Dagger Boards and Thruster Guards

Shown through the literature review, the thrusters which hang off the bottom of the SPAR are a significant risk. Fortunately, unlike some other vessels, they are connected externally which reduces the probability of full fractures. Using guards that would run down the length of the PVC pipe and over the thrusters would take the stress of them in a collision. They could also be designed to act like daggerboards to reduce unwanted side movements from the wind.

Development 4 Steering

Further study is required to improve the efficiency of the thrusters when navigating between waypoints. This would involve changing parameters on APM Planner.

Development 5 Collision Prevention System

Sight glass for a small RaspberryPI camera has been designed and built for the front of the SPAR. The requirements involved stopping cable twisting after the camera was connected to the electrical board. This is solved by making the sight glass into two parts, one that twists onto the current thread and one at the front that acts as a cap. The further investigation involves installing the camera and developing image processing capabilities that would be able to be viewed on the server. Additional developments include using the images to determine obstacles. A method for other vessels to avoid collisions with the SPAR is to install 360-degree radar reflectors, which look like black tape.

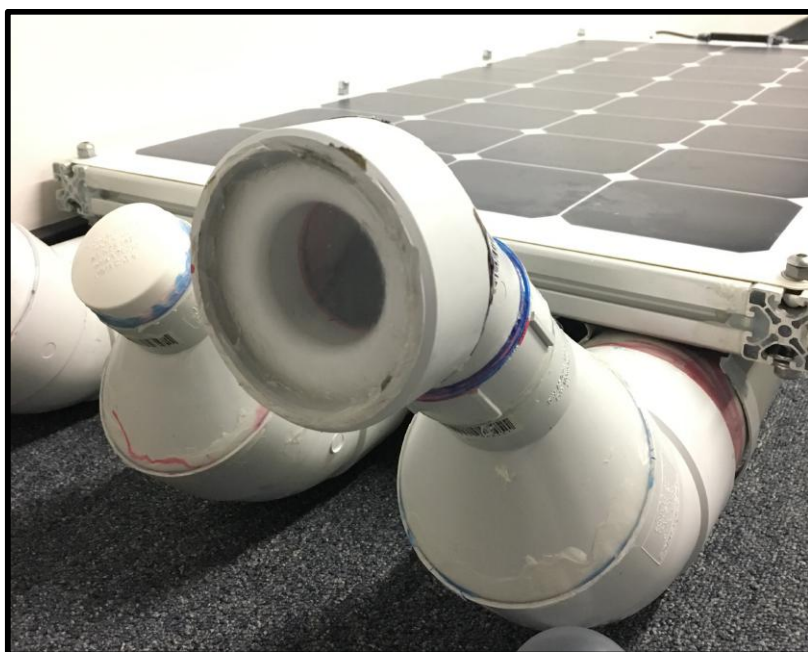

Figure 15: Sight Glass Designed and Build for Future Camera

9. REFERENCES

Ardupilot.org. (2016). Tuning Steering and navigation for a Rover (ver 3.1 and older) — Rover documentation. Available at: <http://ardupilot.org/rover/docs/tuning-steering-and-navigation-for-a-rover.html>

Arendt, H. (2005). Impressed current cathodic protection. *Materials and Corrosion*, 56(4), 271-277. <http://dx.doi.org/10.1002/maco.200403834>

AutoNaut USV. (2018). AutoNaut USV - A new kind of unmanned surface vessel. Available at: <http://www.autonautusv.com/>.

Caccia, M., Bibuli, M., Bono, R., & Bruzzone, G. (2008). Basic navigation, guidance and control of an Unmanned Surface Vehicle. *Autonomous Robots*, 25(4), 349-365. <http://dx.doi.org/10.1007/s10514-008-9100-0>

COLREG. (2003). London: International Maritime Organization.

Clough, B., & Tan, C. (2010). *Planning Mining Technology Automation*. Presentation, Mining Automation and Communication Conference.

Draper, S. (2017). Lecture Notes. Sourced from: GENG5501 (Coastal and Offshore Engineering)

MacMillan, D. (2017). Seacharger: What's this all about?. *Seacharger*. Retrieved from <http://www.seacharger.com/about.html>

Dan, Z., Muto, I., & Hara, N. (2012). Effects of Environmental Parameters on Marine Corrosion of Aluminium Alloys. *Advanced Materials Research*, 569, 95-98. <http://dx.doi.org/10.4028/www.scientific.net/amr.569.95>

Davis, M. and Holloway, D. (2007). A comparison of the motions of trimarans, catamarans and monohulls. *Australian Journal of Mechanical Engineering*, 4(2), pp.183-195.

DJI - The World Leader in Camera Drones/Quadcopters for Aerial Photography. (2017). DJI Official. Retrieved 23 October 2017, from <https://www.dji.com/intelligent-flight-modes>

Garg, P. (2012). The Evolution of Solar Technology. *National Geographic*. Retrieved from <https://voices.nationalgeographic.org/2012/05/30/the-evolution-of-solar-technology/>

Gorter, T., & Reinders, A. (2012). A comparison of 15 polymers for application in photovoltaic modules in PV-powered boats. *Applied Energy*, 92, 286-297. <http://dx.doi.org/10.1016/j.apenergy.2011.10.042>

Håkansson, M., Johnson, E. and Ringsberg, J. (2017). Cost and weight of composite ship structures: A parametric study based on Det Norske Veritas rules. *Proceedings of the Institution of Mechanical Engineers, Part M: Journal of Engineering for the Maritime Environment*, p.147509021769341.

Hodge, J. (2017). Project Report: Autonomous Solar Powered Boat. Sourced from: <http://robotics.ee.uwa.edu.au/theses/>

Item. (2017). *Chemical Resistance of Aluminium in Contact with Important agents* (1st ed.). Retrieved from http://catalog.item24.de/images/medienelemente/DOK/DATA/DOK_DATA_Aluminium__SEN__AIN__V1.pdf

Item. (2017). *Technical Data for Profiles* (1st ed.). Item. Retrieved from http://catalog.item24.de/images/medienelemente/DOK/DATA/DOK_DATA_profil-tech-daten__SEN__AIN__V3.pdf

Kretschmann, L., Burmeister, H., & Jahn, C. (2017). Analysing the economic benefit of unmanned autonomous ships: An exploratory cost-comparison between an autonomous and a conventional bulk carrier. *Research in Transportation Business & Management*. <http://dx.doi.org/10.1016/j.rtbm.2017.06.002>

Lam, B. (2012). Robot Boats Survive Epic Voyage Across the Pacific — So Far. WIRED. Available at: <https://www.wired.com/2012/05/wave-glider-crosses-pacific/>.

Levander, O. (2017). Forget Autonomous Cars—Autonomous Ships Are Almost Here. *IEEE*. Retrieved from <https://spectrum.ieee.org/transportation/marine/forget-autonomous-cars-autonomous-ships-are-almost-here>

Liquid Robotics. (2018). The Wave Glider | Unmanned Surface Vehicle by Liquid Robotics. Available at: <https://www.liquid-robotics.com/wave-glider/overview/>.

Liu, Y. (2017). Lecture Notes. distributed in Degradation of Materials (MECH4428) at The University of Western Australia.

Microtransat.org. (2018). *The Microtransat Challenge*. Available at: <https://www.microtransat.org/>.

Miller, P., Hamlet, M., Sauzé, C., Neal, M., Capper, D., Clark, D., ... & Taylor, L. (2015). MaxiMOOP: A Multi-Role, Low Cost and Small Sailing Robot Platform. In *Robotic Sailing 2014* (pp. 17-30). Springer, Cham.

Mouanga, M., Puiggali, M., Tribollet, B., Vivier, V., Pébère, N., & Devos, O. (2013). Galvanic corrosion between zinc and carbon steel investigated by local electrochemical impedance spectroscopy. *Electrochimica Acta*, 88, 6-14. <http://dx.doi.org/10.1016/j.electacta.2012.10.002>

Muoio, D. (2017). Ranked: The 18 companies most likely to get self-driving cars on the road first. Retrieved from <https://www.businessinsider.com.au/the-companies-most-likely-to-get-driverless-cars-on-the-road-first-2017-4?r=US&IR=T###18-baidu-1>

Nagy, A. (2014). 60 Years Ago, Bell Labs Unveiled the Solar Cell. *Gizmodo*. Retrieved from <https://www.gizmodo.com.au/2014/04/60-years-ago-today-bell-labs-unveiled-the-solar-cell/>

Penny, I. (2017). Solar Voyager: A project that spans over the continents. *Solar Voyager*. Retrieved from <http://www.solar-voyager.com/about.html>

Rodríguez, S., Ibáñez, P., & Farreras, J. (2005). Environmental applications of solar energy (introduction by guest editors). *Solar Energy*, 79(4), 341-342. <http://dx.doi.org/10.1016/j.solener.2005.04.005>

Sailbot.org. (2017). MaxiMOOP | SailBot. Available at: <https://www.sailbot.org/maximooop/>.

Solar Choice. (2017). Commercial Solar PV Price Index for September 2017. *Solar Choice*. Retrieved from <https://www.solarchoice.net.au/blog/commercial-solar-system-prices-september-2017>

Subbaraman, N. (2017). After 2,500 miles on the Atlantic, Scout the ocean drone is missing at sea. *NBC*.

Rock7mobile.com. (2018). Rock Seven | Truly global GPS tracking and messaging systems using Iridium satellite | RockBLOCK Available at: <http://www.rock7mobile.com/products-rockblock>

Warren, N. (1980). *Metal corrosion in boats*. London: Stanford Maritime.

10. APPENDICES

10.1 REQUIREMENTS OMITTED FROM MAIN REPORT

Requirement 6 Adherence to Australian Standards and Marine Standards

There are many Australian and Marine Standards to follow for different locations the SPAR is being tested in. They need to be adhered to with the final design and can be pre-emptively considered before the SPAR is examined.

Requirement 7 Modular design & reusable parts

It is the hope of this report that the SPAR will be used as the basis for future research. With that in mind, the final design needs to allow for modifications where possible. Additionally, the components need to be readily available if they break.

Requirement 8 Safe to operate and handle

Risk analysis needs to be completed, and potential risks must be mitigated through proactive measures. All construction needs to be to a high-quality standard to ensure deburring of edges and other hazards. All electrical equipment should be stored correctly and handled to provide zero chance of electrocution.

Requirement 9 Documentation

Documenting the design process, user manual, final report and all other essential components must be completed and adhered to.

Requirement 10 Technical drawings, schematics & modelling

Alongside the previous requirement, relevant engineering drawings must be completed to allow for full understanding of the SPAR.

10.2 RESOURCES

10.2.1 Physical Hardware

Physical hardware refers to crucial parts vital to running the SPAR. A laptop is a personal tool that requires the USB antenna to connect to the SPAR to issue commands and waypoints. The server is used for storing the continuous data that the SPAR outputs. A car is needed to transport the SPAR to the various testing locations. Table 5 shows the availability, location and cost of the physical hardware of this project.

Table 5: *Physical Hardware*

HARDWARE			
DESCRIPTION	AVAILABILITY	LOCATION	COST (AUD)
Laptop (Windows OS)	Yes	Personal	0
USB Antenna	Yes	UWA	0
Server	Yes	UWA	0
Transport (Vehicle)	Yes	Personal	0
Ocean Transport Retrieval (Motor Boat)	Yes	UWA Oceans Institute	Unknown
Ocean Transport Retrieval (Kayak)	Yes	Personal	0

10.2.2 Computer Software

The computer software required includes the basic Microsoft office suite to write reports, excel tables and a presentation for the seminar assessment. Microsoft Suite, Solidworks and Abaqus are available for free on the University of Western Australia's (UWA) computers. Solidworks is used for creating 3D computer models of the SPAR. Abaqus is used for modelling potential stresses on the structure that could cause permanent damage. Table 6 shows the availability, location and cost of the computer software utilised in this project.

Table 6: *Computer Software*

COMPUTER SOFTWARE			
DESCRIPTION	AVAILABILITY	LOCATION	COST (AUD)
Microsoft Suite	Yes	UWA	0
APM Planner	Yes	Online	0
Solidworks	Yes	UWA	0
Abaqus	Yes	UWA	0

10.2.3 Literature Database

The literature databases are all free and available through UWA. OneSearch gives access to numerous journal articles that were used for the literature review in this report. The UWA library has hard copies and scientific textbooks to clarify and reference engineering calculations. Australian Standards are used to meet specific technical requirements such as pressure relief valves for batteries in enclosed spaces and to ensure that the SPAR does not breach any maritime laws. Table 7 shows the availability, location and cost of the literature databases that may be used in this project.

Table 7: Literature Database

LITERATURE DATABASE (OFFLINE AND ONLINE)			
DESCRIPTION	AVAILABILITY	LOCATION	COST (AUD)
OneSearch	Yes	UWA	0
UWA library	Yes	UWA	0
Australian Standards	Yes	UWA	0

10.2.4 Facilities

The facilities are all on the UWA campus, and all of them have already been utilised for fabrication or consultation. Consultation with the Mechanical Workshop is usually free and has been used for clarifying specific technical details. The Oceans Lab was used for the pipe test, and the UWA pool was used for the two full function tests described in Appendix 3. The SPAR was built in the Robotics Lab using the tools available. The Makers Lab has 3D printers and soldering equipment that is efficiently utilised. Table 8 shows the availability, location and cost of the facilities that may be used in this project.

Table 8: Facilities & Expertise Available

FACILITIES			
DESCRIPTION	CONSULTATION AVAILABLE	LOCATION	COST
UWA Mechanical Workshop	Yes	UWA	\$90 per hour
UWA Makers Lab	Yes	UWA	0
UWA Robotics Workshop	Yes	UWA	0
UWA Computer Labs	Yes	UWA	0
UWA Ocean's Lab	No	UWA	0
UWA Pool	No	UWA	0

10.3 PERSONNEL

As stated previously, I was the last team member to join the project team due to the project requiring a mechanical engineer to design the SPAR halfway through 2017. The project team's details are shown below in Table 9, the team has a great deal of expertise, and only their core competency for this project was shown. Personnel

Table 9: Project Team Members

PERSONNEL			
NAME	POSITION	CORE COMPETENCY	DETAILS
Professor Thomas Bräunl	Project Supervisor	Computer Engineering	Thomas.Braunl@uwa.edu.au
Franco Hidalgo	PhD Student	Software Engineering	fhidalgoh@gmail.com
Chris Kahlefeldt	Postgraduate	Mechatronics Engineering	chris.kahlefeldt@tu-harburg.de
Johnathon Borella	Thesis Student	Mechanical Engineering	jborela@live.com
John Hodge	Thesis Student	Electrical Engineering	tpg@mutabah.net
Shinji Okumura	International Exchange Student: Semester 1 2017	Mechatronics Engineering	22043267@student.uwa.edu.au
Aaron Goldsworthy	Thesis Student	Electrical Engineering	21108324@student.uwa.edu.au

10.4 EXPERIMENTAL TESTING NOTES

Test 1: Pipes Seal Water Test 23/08/17

- Description: Testing the water tightness of the pipes and buoyancy. The pipes had water in them at the end of the test; we think this was due to not using plumbers tape on the thread. They were reasonably buoyant, sitting about a quarter of the way into the water.
- Location: Hydro Lab in the Mechanical Building Pool
- Amendments: Use Plumbers Tape for all future tests, Seal middle pipe with silicon as well.

Test 2: Buoyancy Water Test 13/09/17

- Description: Water Test with everything except the electronics. The boat sat well in the water, about a third to halfway in the water, nothing leaked as we were using plumbers tape this time. It was reasonably level in all directions. We later found out the pool is saturated with salt and there was a large number of salt crystals on the boat the next week.
- Location: Hydro Lab in the Mechanical Building Pool
- Amendments: Don't use this pool again, massive amounts of salt in the water got into the thrusters and all small parts. There was noticeable corrosion on bolts already.

Test 3: Full Water Test (Manual Control) 04/10/17

- Description: Complete Water Test with the full boat package. This was the first test of its kind for the boat, it was linked to an RC Controller for manual testing. The middle pipe is sealed shut permanently and the other two pipes were sealed with plumber's tape and twisted on tight. After the test, there was a definite pressure pop once the pipes had been unscrewed indicating an airtight seal.
- Location: UWA Pool
- Amendments: The boat needs Keels to stop side drift. It requires slightly more weight on its right side to keep completely level. Potentially it could use a 4th pipe to raise the height of the boat out of the water, this will need to be discussed as three pipes is currently sufficient. This could additionally act as a fail-safe in case any of the pipes are damaged and filled with water. There were issues with the autopilot turning the opposite direction and all members will need to be up to date with the software.

Test 4: Full Water Test (autonomous mode) 20/10/17

- Description: Full water test to find the limit of the autonomous functionality. The boat was able to read data points on APM Planner and go to them one by one. It has low accuracy and hit the wall a few times. No damage occurred on the boat, and no water got into the pipes. The ship was having trouble sending data to the server, and there was an initial connection issue.
- Location: UWA Pool
- Amendments: Develop server capabilities linked in with the current electric car website for data logging. Test the system to ensure it is robust. Paint the boat before saltwater testing.

Test 5: Full Water Test (autonomous mode) 30/10/17

- Description: The first Swan River test for the SPAR. It went very well with the autonomous way working by cycling through waypoints. The location was chosen because of it's proximity to the electrical lab. A kayak was borrowed, and although it was easy to follow the SPAR with it, the setup was robust. A simple circular route was taken, the data has been lost though, only photos remain.
- Location: Matilda Bay, Swan River
- Amendments: Purchase a better craft for following the SPAR.



Figure 16: First Swan River Test

Test 6: Full Water Test (autonomous mode) 08/03/18

- Description: Pool test after starting semester 2 of thesis to test all systems are working correctly. Major issues occurred when attempting to setup the SPAR. The internal electronics can be easily disrupted and pulled out of important ports, including the power connections. Moreover, many of the pins need resoldering due to fatigue. There was an issue with the size of the 3-pin wire connections in the SPAR being too large. Additionally, the SPAR is sitting lopsided, the lower side is the one holding the electronic equipment. Furthermore, the two electronic thrusters are cracking and coming out of the 3D printed parts. Using them without reinforcement is in hindsight a bad idea because 3D printed parts are very porous. Reviewed the APM Planner software in order to determine how to change navigation parameters to reduce oversteering. However, due to a lack of understanding this wasn't accomplished.
- Location: chlorine pool
- Amendments: Adjust internal electronics to make more stable. Move central pipe closer to left pipe which contains additional electronics. Remove thrusters and strengthen 3D printed parts. Research how to change navigation parameters and the correct parameters in APM Planner. Install smaller 3-pin connections for internal motor connections. Resolder pins & wires that require it.

Test 7: Solar & GPS Stationary Test 08/04/18

- Description: This test was used to assess the longevity and intensity of the solar panel. Additionally, to test how the the This test needed to be done because the SPAR will be in direct sunlight for extended periods of time. It was conducted over a period of two hours from the middle of the day into the afternoon. The battery level can't be read from the APM Planner

Graphical User Interface (GUI) shown in Figure 17. Instead, the battery level was read manually from the controller. This issue is discussed in section 8 further investigation. The voltage level steadily sat around 13.5 V in direct sunlight and around 13 V in the shade, the results are shown in Table 10 below. This is a good result that shows the SPAR will get a steady amount of power over long periods and in different conditions. The GPS Test was used to understand the how the perceived location differs from the actual situation. Shown in Figure 18, the precise location shifts from one to five meters. It is interesting that the change is continuously in the north direction, this indicates that the GPS might be able to be adjusted. The straight red line across the figure is when the SPAR lost connection and thought it was a 0” latitude and 0” longitude but it is able to adjust back to it’s real location.

- Location: Open Area with good sunlight
- Amendments: Ability for GUI to show live battery level. Determine if the GPS can be adjusted in the APM Planner or controller software.

Table 10: Results of Solar Test

Time (pm)	Voltage (V)	Conditions	Battery Level (Bars)
1:17	13.63	Full Sun	2
2:10	13.55	Full Sun	4
2:45	12.99	Shade	5
3:20	13.51	Full Sun	5

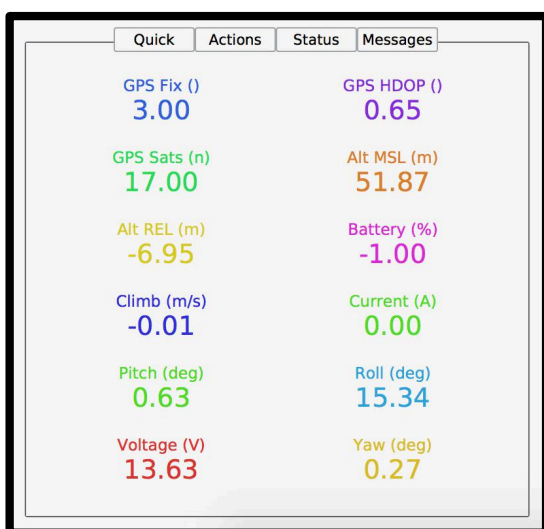

Figure 17: APM User Interface



Figure 18: GPS Shift

Test 8: Full Water Test (autonomous mode) 12/05/18

- Description: This was initially a general saltwater test for the SPAR but shifted after team meetings discussing the SPAR on long voyages and potentially losing contact with the home server. The aim of this test was to see what features the SPAR can use to come back to it's home location. The test was simple; the SPAR was sent outside the range of the radio with the hope that it would automatically come back to home with a loss of connection. The test had unforeseen issues when the SPAR went out of range of radio signal and continued on its path shown in Figure 19 below. Due to the distance from the car park and testing area the equipment including laptop had to be left in the open space. This was a considerable risk as it could have been easily stolen and needs to be mitigated in the future. The SPAR was able to be retained but was unable to be turned off because of a lack of external switch. In future, a full course should always be set.
- Out of range of radio signal, ran straight forward
- Location: Matilda Bay, Swan River
- Amendments: Move testing location. Include a waterproof external on/off switch.

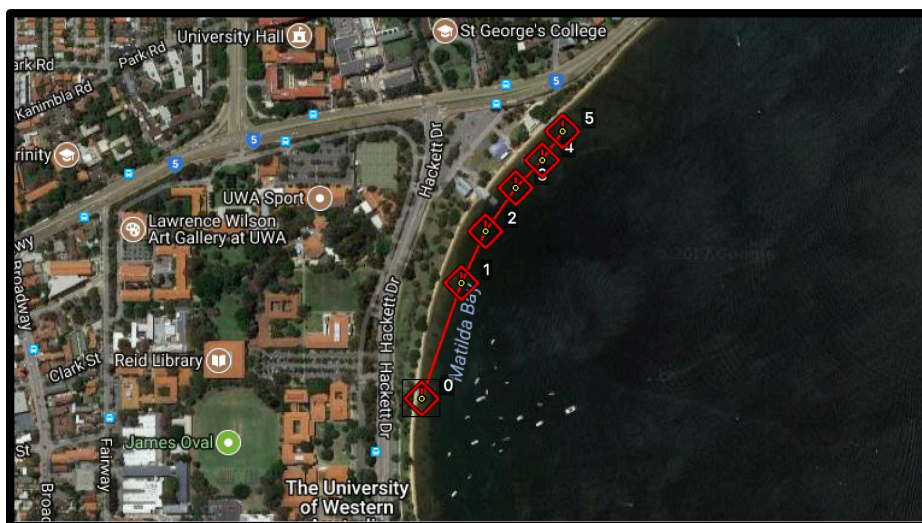

Figure 19: Path Taken

Test 9: Full Water Test (autonomous mode) 23/05/2018

- Description: The testing location moved due to issues had in the previous position to the boat ramp near the UWA business school. The new site is ideal because the car can be parked directly on the water which allows the laptop and other equipment to be locked while testing but still able to communicate with the SPAR. There is also an ideal location to place the SPAR directly in front of the car while setting the waypoints. An external waterproof switch was mounted to the front of the boat. It works great and solves a previous issue where the compass resets to North whenever the SPAR is turned on. Also, it can be stopped from running into walls/land very quickly. The

Three tests can be shown in figure 20 with their relative range and direction, unfortunately the GUI wasn't loading the map so it shows a black screen. The primary aim of this test was to set the basis for changing testing parameters in future experiments. Through testing the SPAR has been demonstrated that it is slower in some directions. In hindsight and reviewing the data it is because it is adjusting its position more often. The position changes can be seen on the figures as small circular dots on the navigation lines. It's unknown why the SPAR does this in some directions and not others. Additionally, the SPAR is faster while turning then going straight. The weather started fine then turned into a more massive swell, it was still considered small, but the SPAR handled differently in the varied conditions. It will be important to test in more large swell before a maiden trip to Rottneest. Figure 22 shows a tremendous difference in inputted waypoints and actual SPAR location. This will need to be tested. Further, it could be that the SPAR lost connection for an extended period. The straight lines of the figures below are the SPAR losing connection quickly then reconnecting, it is confident that it can continue on its course.

o Three tests were run:

- ♣ 1. straightforward and backward test
- ♣ 2. Triangle Test
- ♣ 3. Large Square Test

- Location: J H Abrahams Reserve Crawley WA 6009
- Amendments: Determine if the GUI can be preloaded. Changing navigation parameters. Testing in harsher weather conditions. Figure out how to determine velocity more easily.

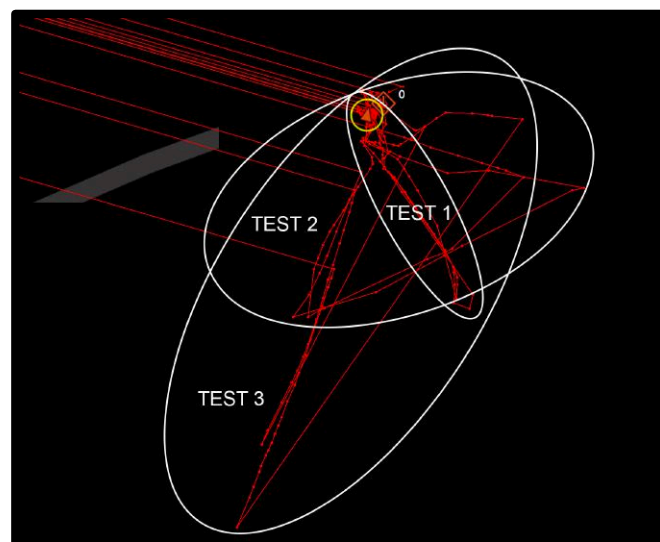

Figure 20: Overview of Testing

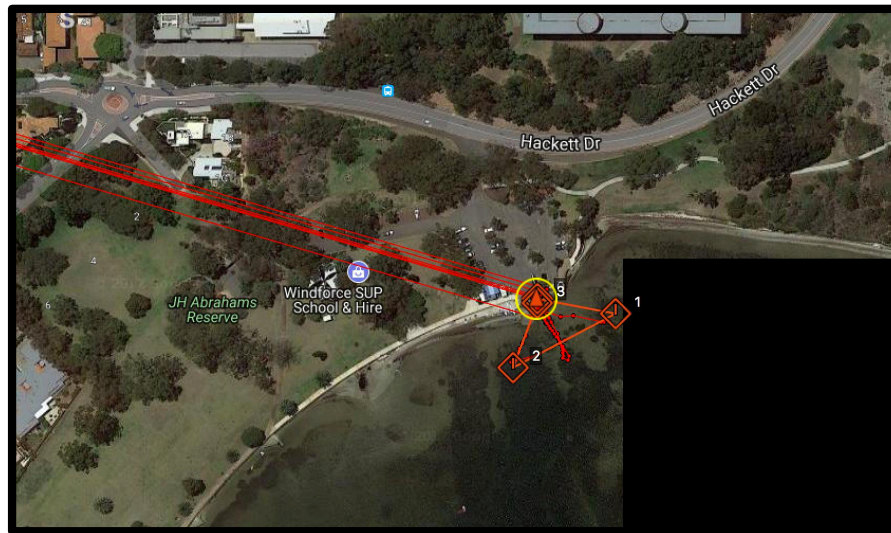

Figure 21: Test 2

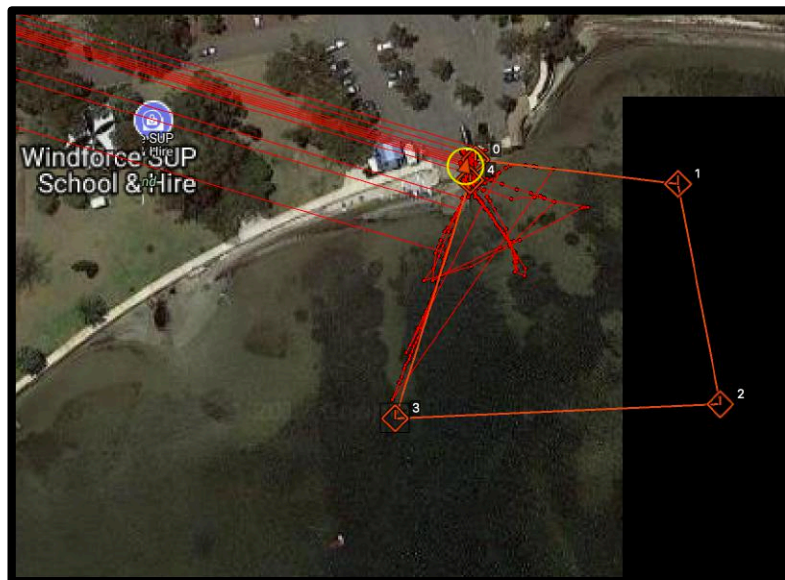

Figure 22: Test 3

Test 10: Full Water Test (autonomous mode) 24/05/18

- Aim: Make a waypoint course, write to SPAR using APM Planner, turn off SPAR, put in the water facing north, turn on and see if the correct direction is taken. This is Important for ocean test. Additionally, make an extended trial to test the
- Description: The initial aim failed. It is possible to write to the SPAR, turn off/on and the route will still be intact. However, for unknown reasons the SPAR will not start in water. This will be tested in the future. The primary test went for over 30 minutes with the SPAR running continuously. The route is shown in figure 24, it's a simple zipper to test turning while still being close to shore. The SPAR was able to drag a person on stand up paddle between waypoint 21 to 22. It was slower than its usual speed but still fantastic horsepower output. The main issue found

during this test was initially thought to be one of the thrusters switching off when adjusting the route. This was later found out that one of the thrusters is actually reversing to turn. This is fine when on land but in water the SPAR is losing a significant amount of inertia every time it adjusts. Voltage warnings occur when the voltage gets close to 10 V. They started happening after waypoint 12 and steadily become more frequent, by waypoint 16 they were at least once every 30 s. On a positive note the SPAR held a constant velocity throughout the test The thruster had a sharp impact and came dislodged, underneath water had gotten into the 3D printed part. Looking at the internal displayed a honeycomb pattern and that the piece is far more porous than previously known. Searching through the APM Planner documentation it was determined how to show the velocity as a graph live, it's shown in figure 25. The velocity shifts between roughly 1 to 2 m/s the high frequency shows the current main issue with the SPAR which is the stop/start jolty motion. If this issue can be solved the SPAR will be significantly more efficient. Figure 23 shows a photo of the battery after the significant test; this was after all the voltage warnings. It is unknown why there would be voltage warnings, but the cell indicates it's at 80%.

- Location: J H Abrahams Reserve Crawley WA 6009
- Amendments: Determine how to turn off reverse. Understand why the SPAR wont start in water. Epoxy the thruster rudders. Learn why voltage drops are happening but battery is still full.



Figure 23: Post Test Battery Check

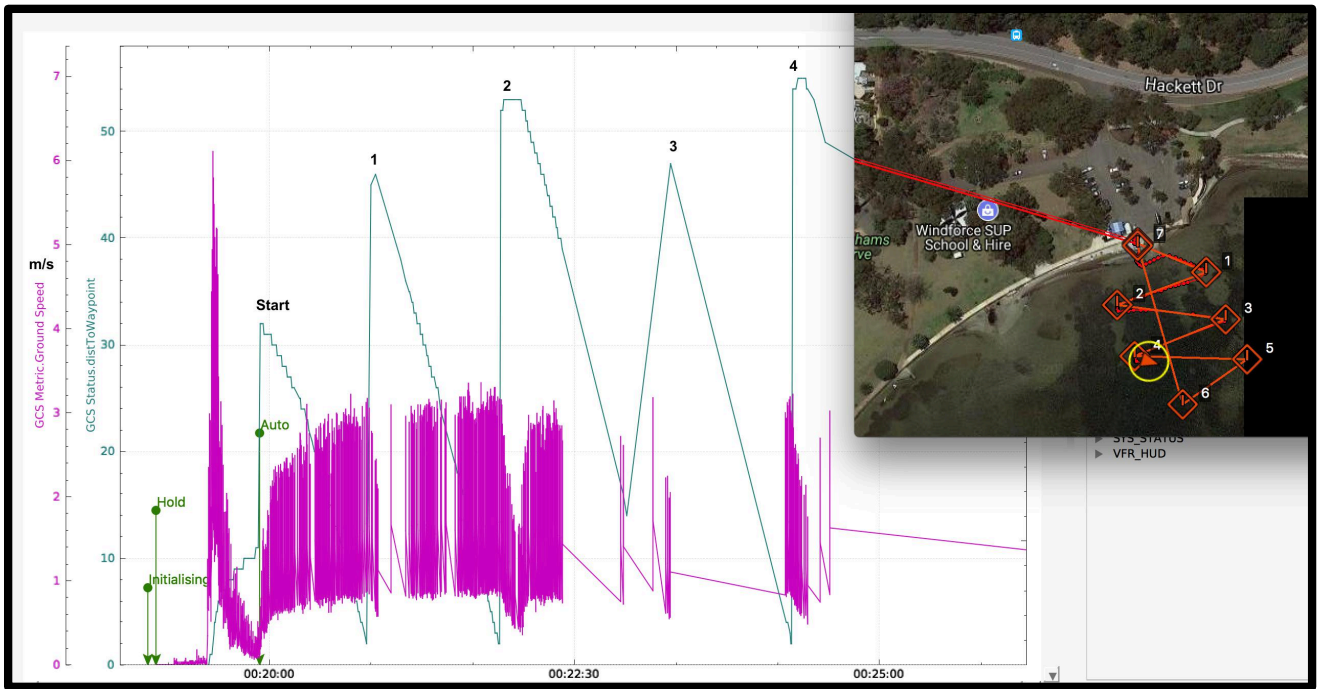

Figure 24: Initial Test of the Day

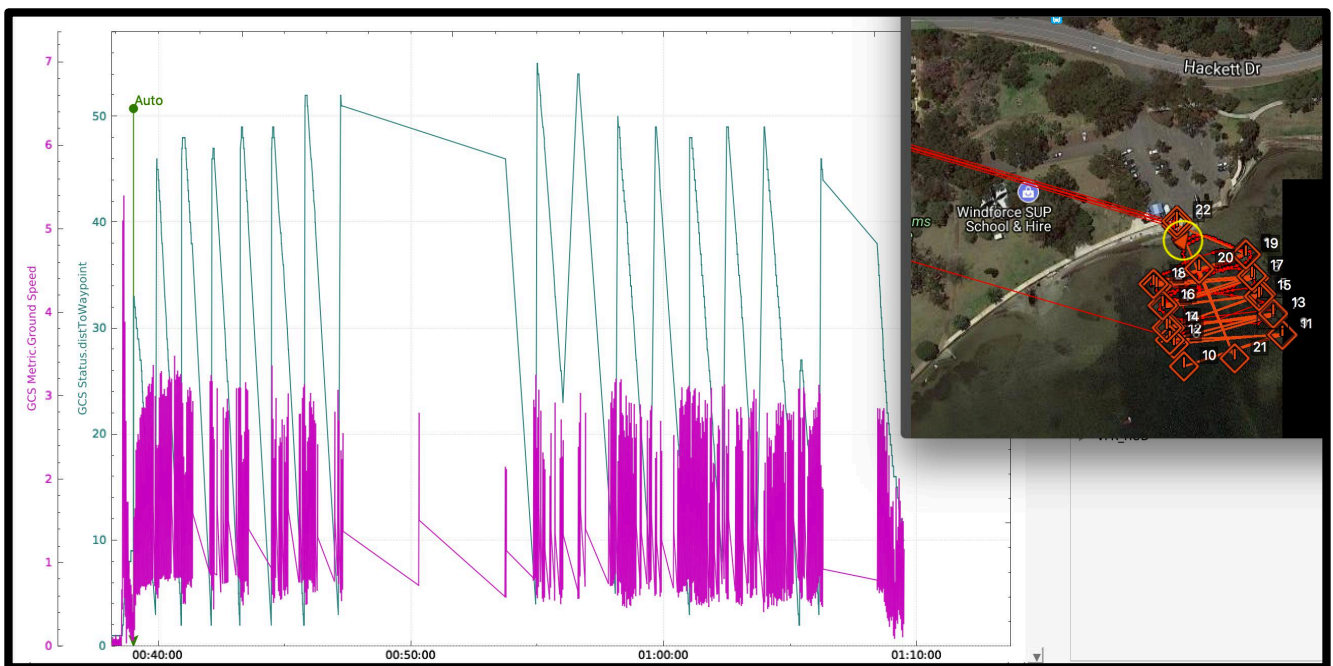

Figure 25: Major Test Route

Test 11: Full Water Test (autonomous mode) 28/05/18

- Description: The first coastal test was attempted at Port Beach in Fremantle due to it's proximity to the car park, and it is a flat beach. A laptop is still required to be in proximity to testing due to the radio signal involved. This test failed due to the weather and because the beach was closed, shown in figure 27.
- Location: Port Beach Rd, North Fremantle WA 6159
- Amendments: Additional Testing off the coast. Long Distance Testing. Increase preparation time when testing.



Figure 26: Ocean Testing Plan



Figure 27: Ocean Test Beach Closure

10.5 BOUYANCY CALCULATIONS

Table 11: Buoyancy Calculations

INDEX	ITEM	VOLUME	NUMBER	TOTAL	UNIT
POSITIVE VOLUMES					
1	Pipe	0.012	3	0.035	m ³
NEGATIVE VOLUMES					
2	Wood	0.0005	2	0.001	m ³
3	Battery	0.0005	4	0.002	m ³
4	Misc.	0.001	1	0.001	m ³
TOTAL BUOYANCY FORCE				315.816	N
GRAVITY FORCES					
5	Frame	5.12791	1	5.128	kg
6	router	0.1	1	0.100	kg
7	Battery	1.366	4	5.464	kg
8	Pipe	1.56	3	4.680	kg
9	Clips	0.069	9	0.621	kg
10	Bolt & T-nut	0.023	26	0.598	kg
11	Solar panel	2.2	1	2.200	kg
12	Misc.	0.5	1	0.500	kg
TOTAL GRAVITY FORCE				189.244	N
PERCENT OF PIPE UNDERWATER				0.599	%

10.6 STRUCTURAL INTEGRITY CALCULATIONS

According to the item beam, technical data sheet (Item 2017) the beams can sustain 5,000 N of bending force. The calculated force of a 1.2m structure falling to the ground with only gravity is around 300 N. It can be assumed that the beam will survive the fall.

10.7 CORROSION

The while definitions of corrosion are shown in Table 13 their relevance to the project is as follows. Uniform corrosion would be expected on all metals used on the SPAR, it is slow and easily monitored so can be dismissed. Crevice corrosion can be expected in the bolt threads and joints of the SPAR. It is tough to track and speeds up over time but is managed by similar methods to the other types of corrosion. If galvanic corrosion occurs, then it will be most likely between the aluminium and carbon steel components with sea water as the electrolyte. A visual representation of reaction is shown in figure 28 and calculations are shown in Table 12.

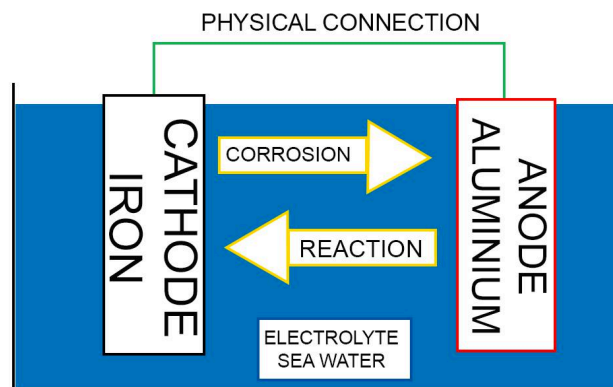

Figure 28: Galvanic Corrosion Visualisation

Table 12: Galvanic Corrosion Calculations

Element	Electrode Reaction	Standard Electrode Potential (V)	Reaction Direction
Aluminium	$Al^{3+} + 3e^{-} \rightarrow Al$	-1.662	Anode
Iron	$Fe^{2+} + 3e^{-} \rightarrow Fe$	-0.44	Cathode
Ecell		1.222	Aluminium Corrodes

Pitting occurs on stainless steels in chlorine-containing environments such as the ocean it is tough to detect and can be devastating. It is added to the list as a precaution as some of the parts could be stainless steel, such as the T-slot Nut. Corrosion fatigue will occur most as the fixtures on the saddles where the reaction forces from the waves will occur shown in figure 30. This is dissimilar to the other types of corrosion and can be prevented by ensuring the parts being fatigued have been designed with a safety factor. Oxidation will occur on surfaces of the SPAR that go through a wet and dry cycle, elements that are splashed by waves but not constantly underwater. This wasn't considered a significant issue until the SPAR undergoes lengthy voyages and can be managed by washing the SPAR with fresh water after testing. However, it was found to be a severe issue and is discussed in the results section of this report.

Table 13: Relevant Types of Corrosion (Lui 2017)

Uniform Corrosion	Uniform removal of metal over the entire surface
Galvanic Corrosion	The corrosion of one metal caused by another in an electrochemical process driven by the potential difference between the two metals.
Crevice Corrosion	Crevice corrosion is a localised attack occurring within crevices or other shielded areas where a small volume of stagnated solution presents.
Pitting	Pitting is a highly localised form of corrosion. It is characterised by pits or holes of various sizes:
Corrosion Fatigue	The presence of a corroded metal, or the action of corrosion, tends to reduce the fatigue life, or decreases the fatigue limit, of a metal.
Oxidation	Reaction between a metal and oxygen at the absence of water.

The while definitions of corrosion protection are shown in Table 14 their relevance to the project is as follows. A sacrificial anode is a type of cathodic protection; it would be a small piece of metal fixed to the frame of the boat, the right metal and size would need to be calculated to ensure the correct effect. Impressed current is also a type of cathodic protection and would require a power source, rectifier and anode. This would be a significant undertaking, costly and seem over the top for this project. The surface covering includes painting the exposed metals, covering critical parts in epoxy and using chemical means to treat metals. It is believed that the aluminium frame has undergone such treatment due to its matte finish familiar with anodised aluminium extrusions. Additionally, the washers and bolts have a galvanic finish which works by destroying before the metal.

Table 14: Relevant Types of Corrosion Protection (Lui 2017)

Sacrificial Anode	A more anodic metal is used in the close vicinity of the target metal to react with the environment
Impressed Current	An electric current is used to slow/halt the corrosion of the target metal
Surface Covering	Surface covering provides barriers between metal and environment

10.8 WAVE ANALYSIS CONTINUED

Graph 2 displays the raw data of elevation against time recorded by a wave buoy located in the North West Shelf of Australia, over a 1600 seconds period. The height is taken every 0.78s and to two decimal places. These are considered the most extreme conditions the SPAR can reasonably go within, so they are ideal for designing to.

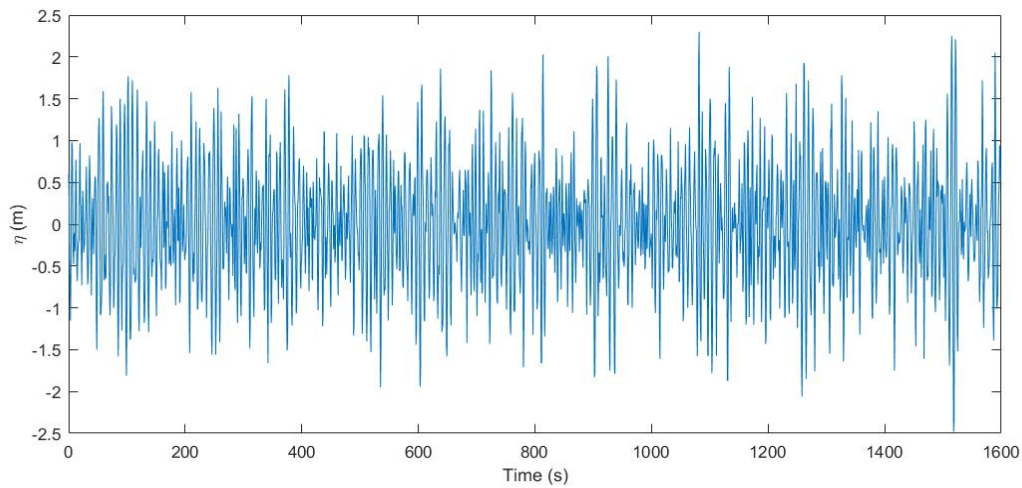

Graph 2: Overall Plot of Wave Elevation

The data was analysed using both the down-crossing and up-crossing method. Using both allows for a highly accurate result, far more accurate than is required. The final results are shown in Table 15. The error is the difference between the down-crossing and up-crossing analysis which is very and allows the assumption that the results are accurate.

Table 15: Wave Analysis Known Values

Known Values		
Symbol	Values	Units
Hs	2.696	m
Hs Error	0.297	%
Hmax	4.71	m
Hmax Error	2.873	%
Tz	5.833	s
Tz Error	0.922	%
g	9.81	m/s ²

Table 16: Wave Analysis Deep Water Values

Assuming Deep Water Analysis of key values $d/L > 0.5$			
Symbol	Equations and Notes	Values	Units
L0	$(g \cdot Tz^2) / (2 \cdot \pi)$	53.1218	m
C0	$(g \cdot Tz) / (2 \cdot \pi)$	9.1071	m/s
k	$(2 \cdot \pi) / L0$	0.118	?

sigma	$(2\pi)/Tz$	1.07717	?
sigma ²	$((2\pi)/Tz)^2$	1.1603	?
Disp	$((2\pi)/Tz)^2 = g*k*TANH(k*d)$	1.159727	Goal Seek
d	goal seek	35.007	m

Table 17: Wave Analysis Breaking Calculations

Deep water Breaking Wave Height			
Symbol	Equations and Notes	Values	Units
Criteria		1/7	
Hb	L0*Criteria	7.5888	m

Table 18: Wave Analysis Predictions

Predicting when a breaking wave will occur			
Symbol	Equations and Notes	Values	Units
N	goal seek	7621247.67	s
H	Height to find	7.588	m
EQN=0	$0 = (RHS/SQRT(2))*SQRT(LN(N/n))-H$	-7.270zE-05	
n	Occurrence	1	
No* days		44454737	s
No* days		515	days

Table 19: Wave Analysis Forces Analysis

Forces Analysis			
Symbol	Equations and Notes	Values	Units
y	Surface	0	m
Umax	$((Hs*PI())/Tz)*(COSH(k*(d+y))/SINH(k*d))$	1.4527	m/s
KC	$(Tz*kUmax)/d$	0.2420	
v	Constant SW	0.000001	
D	Full Pipe Considered	0.1	m
Re	$(Umax*D)/v$	1.45E+05	
Roh	Constant SW	1025	kg/m ³
Cd	Graph	1.2	
Cl	Graph	1	
Cm	Graph	2	

Fdmax	$0.5 * R_{oh} * C_d * D * U_{max}^2$	129.798	N/m
Flmax	$0.5 * R_{oh} * C_l * D * U_{max}^2$	108.165	N/m
Finlinemax	$R_{oh} * D * C_m * \sigma * U_{max}$	320.803	N/m

10.9 THESIS RESEARCH PROJECT FUNDING

The research project funding is distributed differently then previously thought with 50% on materials and 50% on labour. As this thesis project was a design project and the labour was all done in-house which may not be able to be recouped.

Hi Johnathon,

The description of the funding is as below:

Our Faculty allocates \$500 for each Engineering Research project student in each semester, keeping in mind that the project is over two semesters. This amount is split as half made available to purchase materials, samples, or equipment that is required to complete the project, and the other half for labour hire, usually for the Faculty Technical team (i.e. the funds are used to purchase the time of the Technical team, if something needs to be put together, made, assembled, or heavy machinery needs to be operated etc. to complete the project).

If you think you need to purchase any material or 'hire' the Technical team, please liaise with your Supervisor.

I am also happy to assist if you have any queries.

Regards,

John Pougher

 Manager – Academic Services
 Engineering and Mathematical Sciences

10.10 MAINTENANCE

Maintenance 20/05/18

- Description: Maintenance was conducted to see the effect of the testing on the SPAR, incorporate additional features and ensure that all components are in working order after finalising my report. There was a noticeable amount of corrosion in critical areas of the SPAR and is discussed in section 6.2. All the fixtures were holding steady with minimal slippage on the saddles. The black rubber stoppers held up well with little to no damage. Taking the SPAR apart took a considerable amount of time and care due to the small number of nuts and bolts.
- Location: Home, Subiaco WA 6008
- Amendments: None, apart from corrosion SPAR was in good working order.

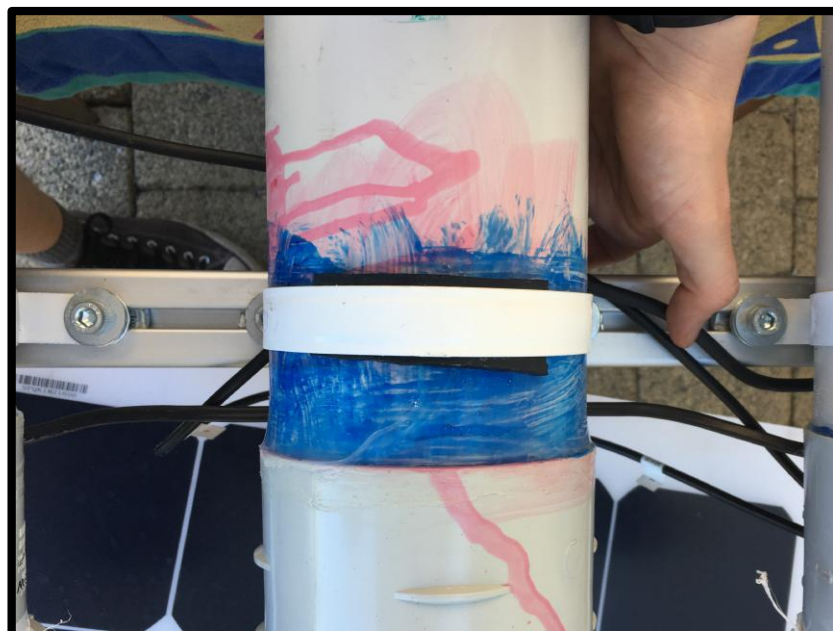

Figure 29: View of Complexity of Wires During Maintenance

10.11 USER GUIDE

1. Land Station Setup

- A laptop and the receiver are required for testing.
- Download APM Planner 2.0
 - <http://ardupilot.org/planner2/>
 - Serial Port: tty.SLAB_USBtoUART
 - Baud Rate: 57600

2. Boat Setup

- Plug in Battery cables
- Turn 3-pin switch on
- Unscrew cap of boat
- Ensure front cable (2-pin Switch) is bent correctly
- Hold cables up
- Slide board in
- Connect the motor cables
- Connect the power cables
- Connect solar cables
- Connect front switch
- Close front cap
- Close back caps
- Check by pressing in front switch and listening for sound, if sound heard turn off

3. Testing Setup

- Open APM Planner
- Plug in USB receiver to Laptop
- connect (top right of screen)
- Ensure flight Data/Actions page is open
- Be prepared to put the SPAR into Hold Mode

4. Making Way Points

- Open FlightPlan/Edit Waypoints
- Click centre on UAV, ensure not at 0,0
- Double click on map to create waypoints
- Write to SPAR
- Double check by Reading waypoints from SPAR
- Ensure when SPAR is turned on at front switch it is facing North

5. Changing parameters

- Must be connected with SPAR
- Open config/tuning
- All Parameters
- Change Value
- Write to SPAR

6. Post Testing

- Clean with fresh water
- Turn off and remove

10.12 Comparison Table of Small Solar Autonomous Marine Vessels

	Seacharger	Solar Voyager	That'll Do Two	That'll Do One	AutoNaut	Wave Glider	Sailbuoy	Scout	Joker	SPAR
Powersource	Solar	Solar	Solar	Wind/Solar	wave/solar	wave/solar	Wind/Solar	Solar	Solar/Sail	Solar
Material	Fibreglass	Steel (assumed SS)	Fibreglass	Fibreglass	Fibreglass	Fibreglass	Fibreglass	Fibreglass	Fibreglass	PVC, Steel, Al
Length	2.3 m	5+ m	1.4 m	1.8 m	2-7m	3 m	2 m	4 m	1.3 m	1.5 m
Displacement	22 kg	Unknown	10 kg	15 kg	30+ kg	Unknown	60 kg	Unknown	13 kg	30+ kg
Velocity	1.5 m/s	Unknown	Unknown	Unknown	2-4 m/s	1.5 m/s	1 m/s	2 m/s	Unknown	1-2 m/s
Endurance	3 days in the dark	Unknown	Unknown	Unknown	Unknown	12 months	6 months	Unknown	Unknown	Unknown
Power	2 x 100 W solar panels	240 W	120 W	120 W	1-3 solar panels	180 W	1 solar pane	3 solar panels	Solar Panel	1 Solar Panel
Batteries	Yes	Yes	Yes	Yes	Yes	Yes	Yes	Yes	Yes	Yes
Motors	1 motor on keel	2 motors vertically placed	1 motor	2 motors	0	0	0	1 Motor	1 motor	2 motors
Communication	Satellite	Satellite	Satellite	Satellite	Satellite	Satellite, cell, wifi	Satellite	Satellite	SPOT Trace	Radio, 3G
Autopilot	Arduino-based	Unknown	3X PIC18F14K22s	Unknown	Unknown	Unknown	Arduino	2 arduino mega	Picaxe	Ardupilot
Hull Type	Monohull (deep Keel)	Monohull (Vshape design)	monohull, sailboat	Monohull	Monohull, Fins on hull	Monohull, hanging keel	monohull sail	Monohull no keel	Monohull Sail boat	Multihull/Raft
Distance	6500 Nm	1000 Nm	Unknown	1000 - NM	5000+ Nm	1.4 million Nm tested	5000+ Nm	1300 Nm	5000 Nm	1 Nm
Usage	Research	Research	Research	Research	Commercial/Research	Commercial	Commercial	Research	Research	Research
Smart tools	Heading Mode	Unknown	Unknown	Unknown	Multiple	Multiple	Multiple	Multiple	Unknown	None
Failure	Rudder Damage	Batteries stopped charging	NA	contact lost	NA	NA	NA	Motor Damage	NA	NA
Link	http://www.seacharger.com/	http://www.solar-voyager.com/index.html	https://www.microtransat.org/2017_epsom_boat.php	http://www.epstem.org.uk/	http://www.autonautsv.com/	https://www.liquidrobotics.com/wave-glider/how-it-works/	http://sailbuoy.no/	http://gotransat.com/build.html	http://user28153.vseasily.co.uk/autop.htm	http://robotics.ee.uwa.edu.au/theses/

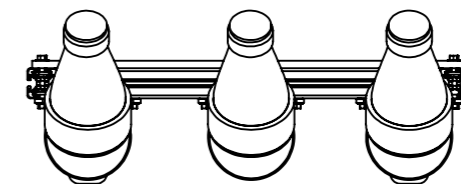
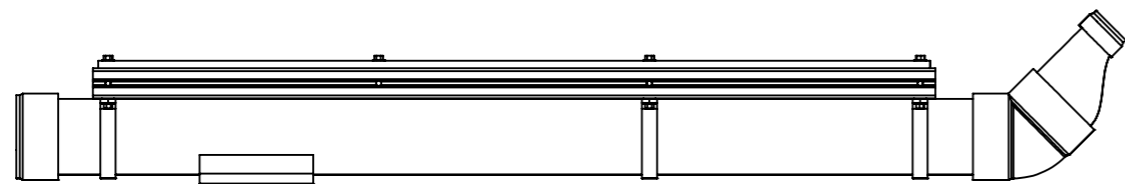
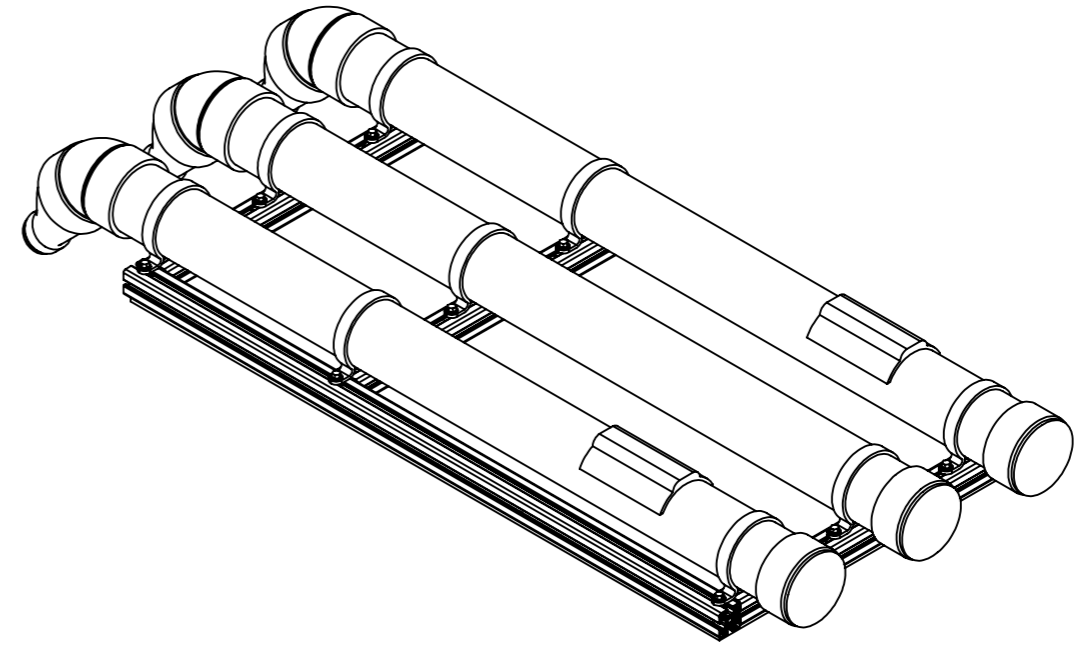
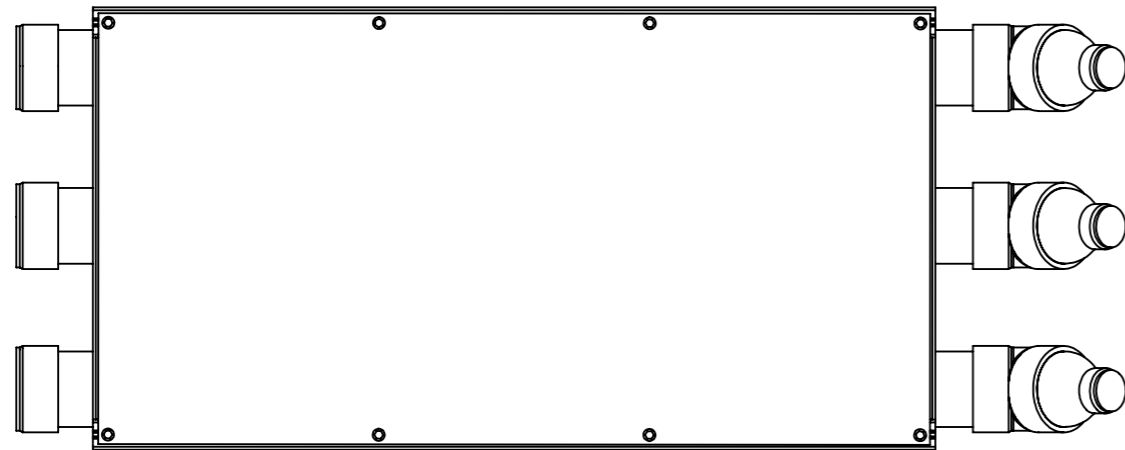

UNLESS OTHERWISE SPECIFIED: DIMENSIONS ARE IN SI STANDARDS		FINISH: REFER TO SOLAR POWERED AUTONOMOUS RAFT (SPAR) THIS REPORT		DEBURR AND BREAK SHARP EDGES		DO NOT SCALE DRAWING		REVISION	
REVIEWED BY		DATE: 27/05/18		TITLE:		ASSEMBLY DRAWING			
NAME:						10.13 Solar Powered Autonomous Raft (SPAR)			
SIGNATURE:		<i>Borella</i>		NOTE: REFER TO BILL OF MATERIALS AS PART OF THIS REPORT FOR FULL BREAKDOWN OF PARTS. THIS DRAWING IS A GUIDE ONLY		DRAWN BY: JOHNATHON BORELLA		A3	
		WEIGHT: 30 KG		SCALE: 1:10		SHEET 1 OF 1			

10.13

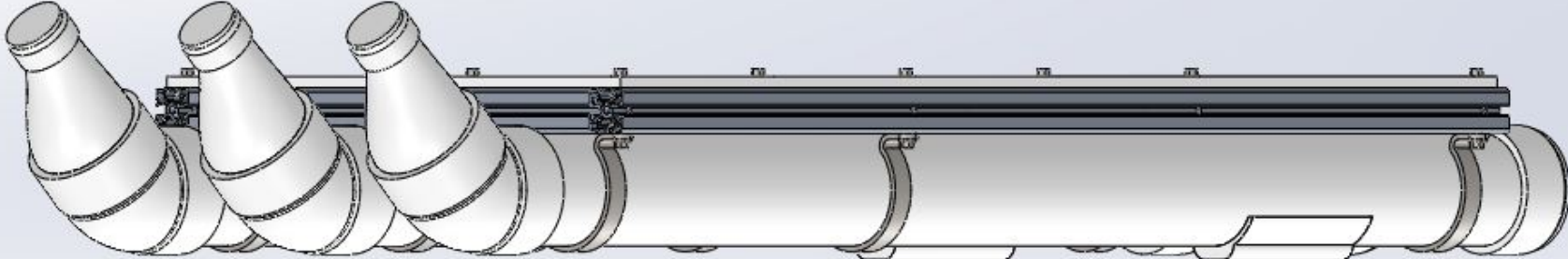

10.13

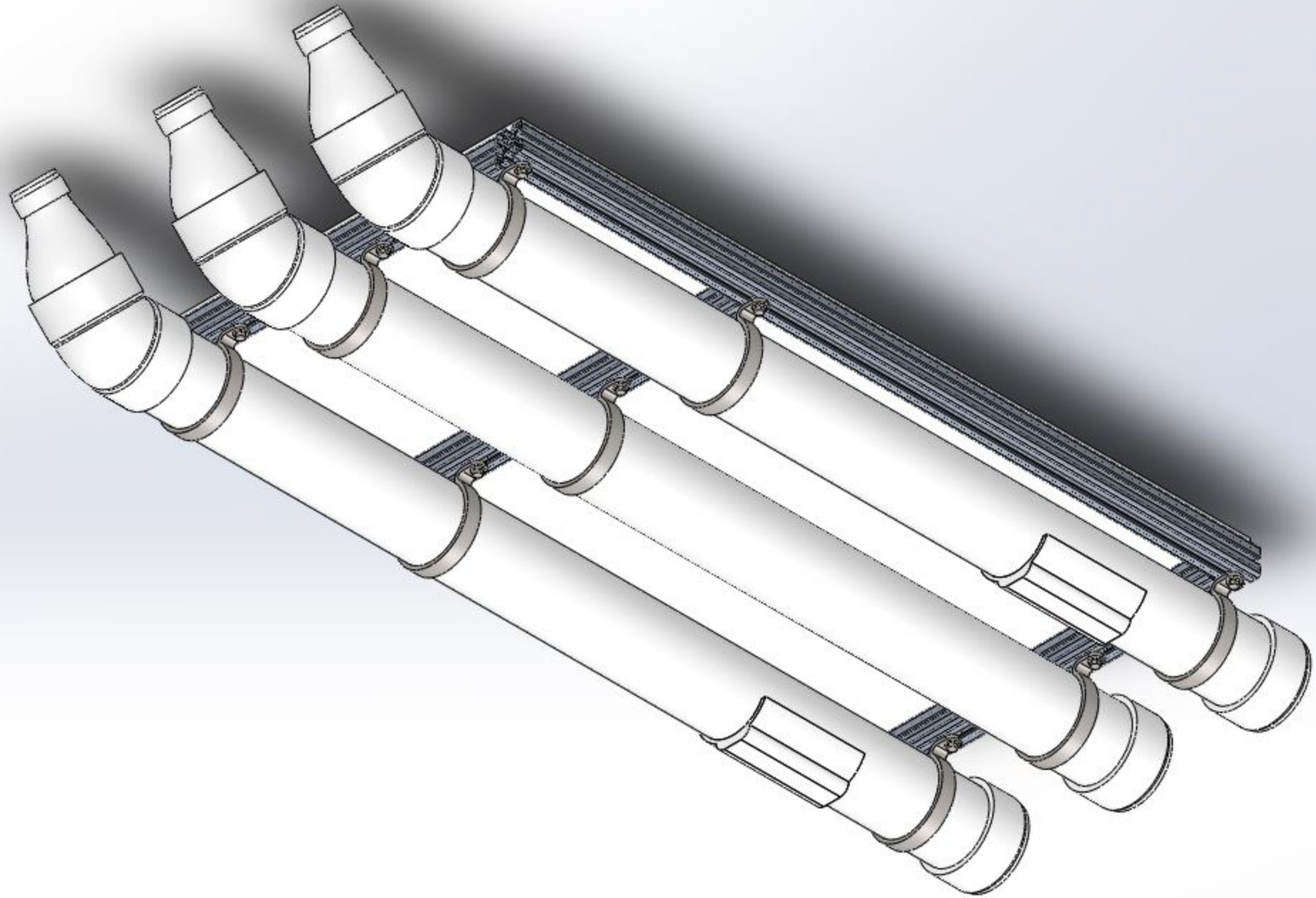

10.13

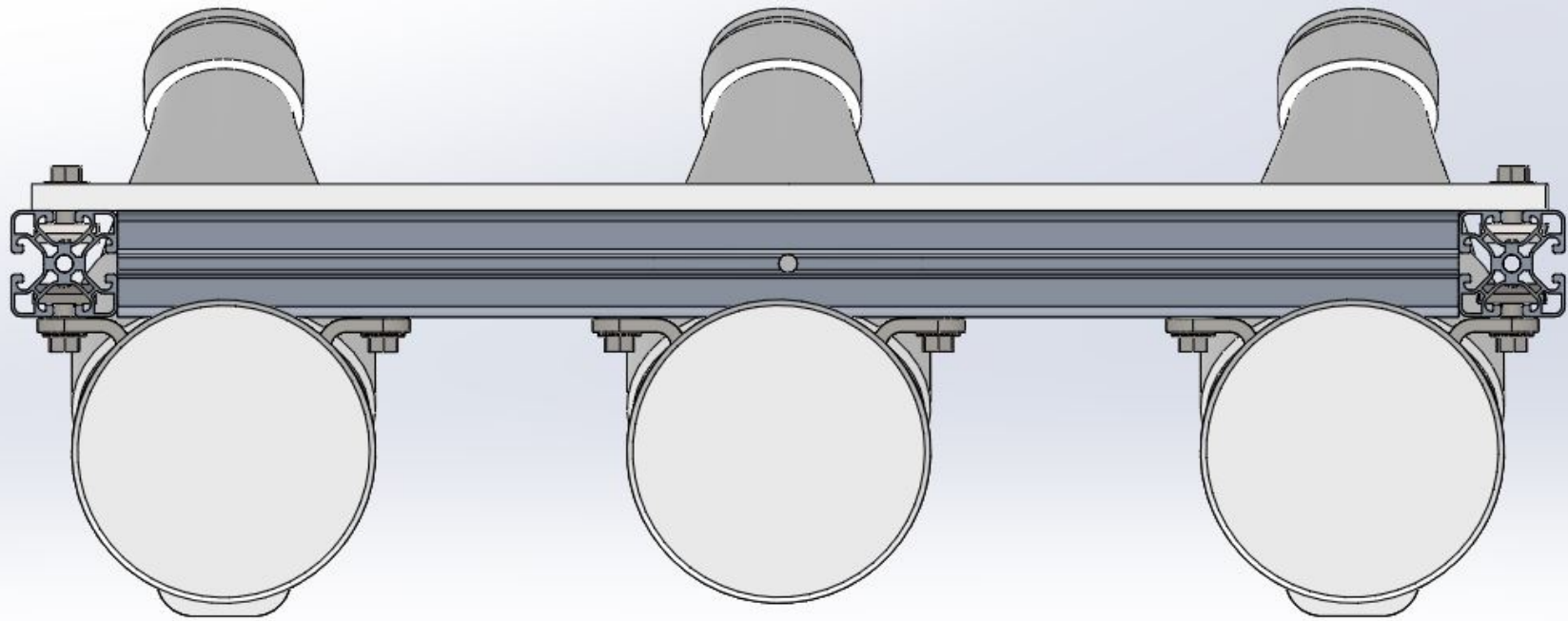

10.14 Thesis: Solar Powered Autonomous Raft (SPAR)

Johnathon Borella

5x5 Risk Matrix for Treated

Catastrophic Failure of the SPAR

Likelihood of occurrence

Environment	Assets/Business Disruption	Reputation	Health and Safety		Never heard of in industry	Heard of in industry	Happened several times in industry or has happened in our company	Happened several times per year in the industry or incident has occurred several times in our company or at least once in our location	Incident has occurred several times at our location
					Incident is highly unlikely but may occur under exceptional circumstances during the lifecycle phase	Incident is unlikely but possible to occur at the location during the lifecycle phase	Incident could occur at the location during the lifecycle phase	Incident will probably occur in most circumstances at the location during the lifecycle phase	Incident is expected to occur in most circumstances at the location during the lifecycle phases
					A	B	C	D	E
Limited environmental impact, spill contained on site	No disruption to process, minimum cost for repair (cost <1, 000 A\$)	Public awareness of the incident may exist, there is no public concern	First aid case-or-minor reversible health effects of no concern	1	L	L	L	M	M
Minor environmental impact, reportable incident no permanent effect (<100 bbl)	Possible brief disruption of the process; isolation of equipment for repair (cost <10,000 A\$)	Some local public concern, slight local media or political attention	Medical treatment case-or-reversible health effect of concern, no disability	2	L	L	L	M	M
Moderate environmental impacts, extends beyond site boundary, repeated exceedance of statutory or prescribed limit	Plant partly down, process can possibly be restarted (cost<100,000 A\$)	Regional public concern, negative local media or political attention	Lost time injury/illness-or-severe reversible health effect from acute, short term exposure	3	L	L	M	M	H
Serious medium term environmental impacts, extended exceedance of statutory or prescribed limit	Partial loss of plant, plant shut-down for up to 4 weeks (cost <1,000,000 \$A)	National public concern, extensive negative national media or political attention	Single fatality –or- permanent disability –or- exposures resulting in irreversible health effect of concern	4	M	M	M	H	H
Severe environmental damage extending over large area	Total loss of plant or plant shut-down for more than 4 weeks (cost<10,000,000 \$A)	International public concern, negative media or political attention, intervention from Government	Multiple fatalities –or- health effects resulting in multiple disabling illness learning to early mortality	5	M	M	H	H	H

10.14

Thesis Report Risk Register: Solar Powered Autonomous Boat (SPAR)

Johnathon Borella

Date 27-May-18

Project or process activity	Cause / Threat / Opportunity	Event and consequence description	Untreated risk			Consequence modification	Likelihood modification	After treatment			Person responsible	Document reference	Date implemented
			Consequence	Likelihood	Risk			Consequence	Likelihood	Risk			
SPAR Testing	Batteries Exploding	The Batteries expand to the point of combustion, being in enclosed pipes they have a risk of creating bomb	4	D	H	Attach pressure relief valves onto pipes	simple Modification	2	A	L	JB	Report	19/8/17
SPAR Testing	run over by larger boat		4	C	M	Following Marine Standard, One White light is needed on SPAR. Use enclosed solar powered garden light.	Attached to SPAR	4	A	L	JB	Report	20/3/18
SPAR Testing	Hit Rock or rubbish	The SPAR hits a foreign object and causes a <u>threatening impact, with the potential for sinking</u>	2	E	M	Design for impact with high strength materials	Integrity calculations	1	E	L	JB	Report	26/6/17
SPAR Testing	Frame Corrodes	Joints and important fixtures corrode and important parts of the SPAR get disjointed	3	C	M	Include corrosion resistant functions, Painting the outside, sacrificial anodes	painting is simple, anodes more complicated	1	A	L	JB	Report	20/5/18
SPAR Testing	Pipe Seal breaks	One or more of the pipes gets broken and fills with water	4	B	M	Attach enough pipes so the structure can float if one pipe is fractured	currently 3 pipes and room for a 4th, much harder after that	2	A	L	JB	Report	26/6/17
SPAR Testing	Lost connection with SPAR	Complete loss of connection with SPAR due to communicaiton systems failure	3	C	M	Multiple types of communication with SPAR, 3G, wifi, GPS	on/off switch on outside of boat	2	A	L	JH	Report	19/4/18
SPAR Testing	Motors clogged with seaweed/rubbish	The motors get stuck with excess seaweed/rubbish and unable to continue	3	D	M	Track speed and implement a reverse, turn and forward move to dislodge seaweed/rubbish	able to implement through APM Planner	2	B	L	JB	Report	27/10/17
SPAR Testing	Solar panel loses efficiency	The solar panel gets covered in salt, bird poo or multiple storms reduce the max output of power	4	D	H	Design boat to sit slightly in the water so it occasionally gets washed/covered by waves. Also ensure the motors can work at low efficiencies of solar panel's power output	Both are simple calculations and can occur easily	2	C	L	JB	Report	27/10/17
SPAR Testing	SPAR is capsized	The SPAR is capsized by a breaking or tipping wave and unable to right itself	4	C	M	Very hard to design the SPAR to flip itself back onto it's correct side. Instead, Design so center of gravity is very low in the water. Estimate probability of breaking wave in voyage region. Estimate angle required to flip SPAR	Modifications are able to be implemented, they do not solve the unlikely issue of the boat being upside down simply mitigate it	4	A	L	JB	Report	12/3/18
Final Thesis Report	Scope Changes	One or more of the aims of the proposal changes and effect the final result of the proposal	3	C	M	Weekly meetings with my supervisor in order to keep on top of changes that happen with projects like these	I've had weekly meeting with my supervisor since the beginning of the semester and will continue them for the rest of the thesis	1	A	L	JB	Report	27/5/18
Final Thesis Report	Project Failure	One or more of the SPAR Testing risks occur and causes catastrophic failure to the thesis	4	B	M	Ensure that SPAR risks are tracked and managed, keep documentation of the entire process so that if a catastrophic failure occurs there is still results	very likely	1	B	L	JB	Report	27/5/18

10.16

Thesis Report Bill Of Materials: Solar Powered Autonomous Raft (SPAR)

Johnathon Borella

Period: 12/06/2017 - 27/10/2017

Date: 12/6/17

Last Updated: 27/5/18

Purchased Materials as of 27/10/2017											
Item	Name	Description	Drawing No.	Type	Assembly Ref.	Rev.	Date	Qty	Unit Price	Total price	Link
1	Item Beam	Profile 8 40x40 E, Natural Item Beam (per meter)						3.743	\$0.00	\$0.00	http://prod
2	T-slot Nut	T-slot Nut 8						26	\$0.00	\$0.00	http://www
3	Standard Fastener	Standard-Fastening Set 8 (Fastener & M8 bolt)						6	\$0.00	\$0.00	http://www
4	M8 Bolt	Standard M8 20mm bolt						26	\$0.70	\$18.20	https://ww
5	M8 Washer	Standard M8 Washer						27	\$0.30	\$8.10	https://ww
6	Pipe Saddle	100mm Steel staddle fixed to frame						9	\$2.27	\$20.41	https://ww
7	PVC straight pipe	100mm straight pipe (per meter)						3	\$8.70	\$26.10	https://ww
8	PVC 45* Bend	100mm 45 deg F-F bend						3	\$5.35	\$16.05	https://ww
9	PVC Thread Adaptor	100mm Pipe to Thread adaptor						3	\$6.40	\$19.20	https://ww
10	PVC Threaded Cap	100mm Threaded Cap with O ring						3	\$4.44	\$13.32	https://ww
11	PVC Taper pipe	100mm to 50mm Taper Pipe						3	\$4.44	\$13.32	https://ww
12	PVC Cap End	50mm Cap Cap End						1	\$3.75	\$3.75	https://ww
13	PVC Thread Adaptor	50mm Male Pipe to Thread Adaptor						2	\$4.38	\$8.76	https://ww
14	PVC Thread Conn.	50mm Female Thread connector						2	\$5.29	\$10.58	https://ww
15	PVC Push on Cap	65mm Push on Cap						2	\$4.84	\$9.68	https://ww
16	PVC Glue	500ml Type N PVC Cement Non-Pressure						1	\$6.90	\$6.90	https://ww
17	PVC Primer	125ml Red Priming Fluid						1	\$4.90	\$4.90	https://ww
18	Plumbers Tape	12mm thread seal tape (per 10 meters)						8	\$0.70	\$5.60	https://ww
19	Silicone tube	Roof & Gutter silicone						3	\$9.98	\$29.95	https://ww
20	Silicone holder	9" Calking Gun (Personal)						1	\$2.00	\$2.00	https://ww
21	Motor	T100 Brushless Marine Thruster						0	\$150.85	\$0.00	http://blue
22	Motor Mount	Mounting Bracket						2	\$5.00	\$10.00	http://blue
23	Motor Fixture	3D Printed part (UWA Makers)						2	\$0.00	\$0.00	NA
24	All Plastic Glue	3ml All plastic Fix Adhesive & Primer						3	\$8.44	\$25.32	https://ww
25	Plastic Epoxy	14ml Epoxy (Robotics Workshop)						1	\$0.00	\$0.00	https://ww
26	Wooden Beam	Pine Wood Beam (Robotics Workshop)						2	\$0.00	\$0.00	NA
27	Aluminium sheet	Thin Aluminium Sheet (Robotics Workshop)						1	\$0.00	\$0.00	NA
28	One-way Valve	Pressure Relief Valve for enclosed spaces						2	\$0.00	\$0.00	https://ww
29											
30											
Grand Total:										\$252.14	

10.16

Thesis Report Bill Of Materials: Solar Powered Autonomous Raft (SPAR)

Johnathon Borella

Period: 26/02/2018 - 28/05/2018

Date: 27/5/18

Last Updated: 27/5/18

Proposed Purchase Materials as of 27/10/2017											
Item	Name	Description	Drawing No.	Type	Assembly Ref.	Rev.	Date	Qty	Unit Price	Total price	Link
1	Spray Paint	White Knight 310g Rust Guard Epoxy Enamel						2	\$18.70	\$37.40	https://ww
2	Spray Primer	White Knight 300g Rust Guard All Purpose Primer						2	\$19.60	\$39.20	https://ww
3	3Pin M/inline	3-Pin Connection Female						2	\$11.00	\$22.00	Altronics
4	3Pin F/inline	3-Pin Connection male						2	\$5.90	\$11.80	Altronics
5	Wood Screws	Painted for motor connection 3.5x16 ptk45						1	\$2.85	\$2.85	Bunnings
6	Waterproof Switch	External Switch IP67						1	\$19.99	\$19.99	Jaycar
7	Light	Solar Garden light, plastic cover						2	\$4.00	\$8.00	Bunnings
8	PVC connection	PVC Taper 50x80mm						1	\$10.50	\$10.50	Bunnings
9	PVC connection	PVC adaptor male						1	\$4.20	\$4.20	Bunnings
10	PVC connection	PVC Bend						1	\$2.60	\$2.60	Bunnings
11	PVC connection	PVC Flange						1	\$1.15	\$1.15	Bunnings
12	Perspex	Perspex for sight glass						1	\$19.99	\$19.99	Officewor
13											
14											
15											
16											
17											
18											
19											
20											
21											
22											
23											
24											
25											
26											
27											
28											
29											
30											
Grand Total:										\$179.68	

10.16

Thesis Report Bill Of Materials: Solar Powered Autonomous Raft (SPAR)
 Johnathon Borella
 Period: 12/06/2017 - 28/05/2018

Date: 12/6/17
 Last Updated: 27/5/18

Purchased Electronic Components											
Item	Name	Description	Drawing No.	Type	Assembly Ref.	Rev.	Date	Qty	Unit Price	Total price	Link
1	Solar Panel							1	\$261.84	\$261.84	http://www
2	Solar Charger							1	\$31.21	\$31.21	http://www
3	RS232→TTL Board							1	\$6.25	\$6.25	http://www
4	5V Suply							1	\$4.95	\$4.95	https://ww
5	2.25mm 4pin DF13							1	\$1.40	\$1.40	http://au.r
6	2.25mm 6pin DF14							1	\$1.22	\$1.22	http://au.r
7	2.25mm crimps							1	\$7.95	\$7.95	http://au.r
8	2.1mm DC Jack							1	\$2.09	\$2.09	http://au.r
9	Various Wire (26AWG)							3.7	\$0.30	\$1.11	http://www
10	Power Wire							3.3	\$0.75	\$2.48	http://www
11											
12											
13											
14											
15											
16											
17											
18											
19											
20											
21											
22											
23											
24											
25											
26											
27											
28											
29											
30											
Grand Total:										\$320.50	

10.17

Thesis Report Gantt Chart: Solar Powered Autonomous Raft (SPAR)

Johnathon Borella

Period: 12/06/2017 - 27/10/2017

Task Index	Task Name	Start Date	End Date	Duration (Days)	Days Complete	Days Remaining	Percent Complete
0	Meet SPAB Team	12/6/17					
1	Design Frame	12/6/17	26/6/17	14	14.00	0.00	100%
2	Fabricate Frame (Completed by Company)	26/6/17	3/7/17	7	7.00	0.00	100%
3	Design Electronics Runner (Shingi)	6/7/17	9/7/17	3	3.00	0.00	100%
4	Fabricate Electronics Runner (Chris & Franco)	22/7/17	25/7/17	3	3.00	0.00	100%
5	Design Solar Panel Fixtures	23/7/17	26/7/17	3	3.00	0.00	100%
6	Design Pipe's	26/7/17	5/8/17	10	10.00	0.00	100%
7	Fabricate Pipe	6/8/17	20/8/17	14	14.00	0.00	100%
8	Test: Only Pipes in water	23/8/17	24/8/17	1	1.00	0.00	100%
9	Design Frame -> Pipe attachment	24/8/17	31/8/17	7	7.00	0.00	100%
10	Fabricate Frame -> Pipe attachment	30/8/17	9/9/17	10	10.00	0.00	100%
11	Design Motor Fixture (Chris)	21/8/17	28/8/17	7	7.00	0.00	100%
12	Fabricate Motor Fixture (Chris)	28/8/17	4/9/17	7	7.00	0.00	100%
13	Test: Frame & pipes	13/9/17	14/9/17	1	1.00	0.00	100%
14	Design Battery holder	15/9/17	22/9/17	7	7.00	0.00	100%
15	Fabricate Battery Holder	24/9/17	1/10/17	7	7.00	0.00	100%
16	Review Complete System	1/10/17	5/10/17	4	4.00	0.00	100%
17	Test: Full SPAB water test	4/10/17	5/10/17	1	1.00	0.00	100%
18	Introduction to Electrical & Software Systems	6/10/17	18/10/17	12	12.00	0.00	100%
19	Write Thesis Proposal	13/10/17	27/10/17	14	14.00	0.00	100%

Start Date	12/6/17
------------	---------

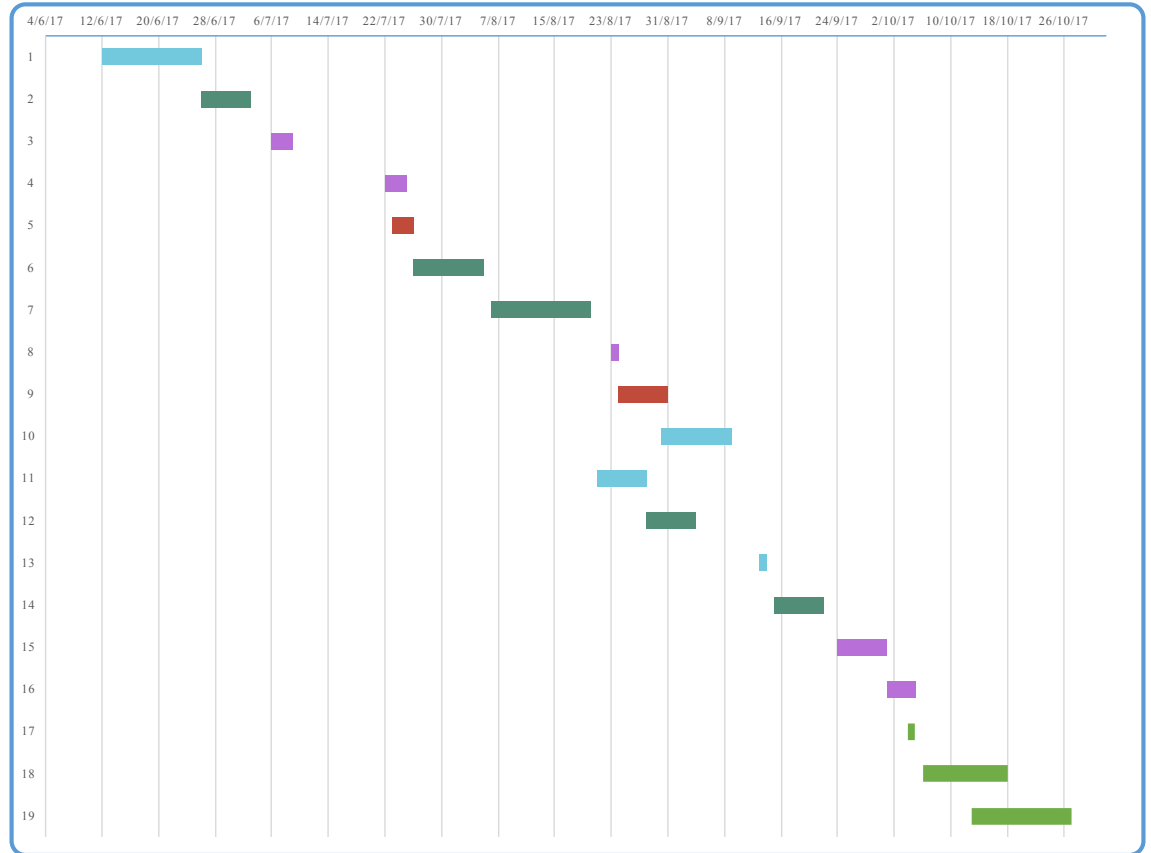

10.17

Thesis Report Gantt Chart: Solar Powered Autonomous Raft (SPAR)

Johnathon Borella

Period: 26/02/2018 - 28/05/2018

Start Date	26/2/18
------------	---------

Task Index	Task Name	Start Date	End Date	Duration (Days)	Days Complete	Days Remaining	Percent Complete
0	Meeting with SPAB Team	26/2/18	27/2/18	1			
1	Website & Server Setup	26/2/18	12/3/18	14	0.00	14.00	0%
2	4th Pipe Fabrication & Attachment	12/3/18	19/3/18	7	0.00	7.00	0%
3	Keel Design	19/3/18	22/3/18	3	0.00	3.00	0%
4	Keel Fabrication	22/3/18	25/3/18	3	0.00	3.00	0%
5	Painting & Final Touches	24/3/18	31/3/18	7	0.00	7.00	0%
6	Final Test	1/4/18	15/4/18	14	0.00	14.00	0%
7	Post Test: Review Boat	15/4/18	20/4/18	5	0.00	5.00	0%
8	Abstract	20/4/18	27/4/18	7	0.00	7.00	0%
9	Seminar (9/05/18)	2/5/18	9/5/18	7	0.00	7.00	0%
10	Digital Poster (11/05/18)	4/5/18	11/5/18	7	0.00	7.00	0%
11	Final Report (28/05/18)	14/5/18	28/5/18	14	0.00	14.00	0%
12			0/1/00	0	0.00	0.00	0%
13			0/1/00	0	0.00	0.00	0%
14			0/1/00	0	0.00	0.00	0%
15			0/1/00	0	0.00	0.00	0%
16			0/1/00	0	0.00	0.00	0%
17			0/1/00	0	0.00	0.00	0%
18			0/1/00	0	0.00	0.00	0%
19			0/1/00	0	0.00	0.00	0%

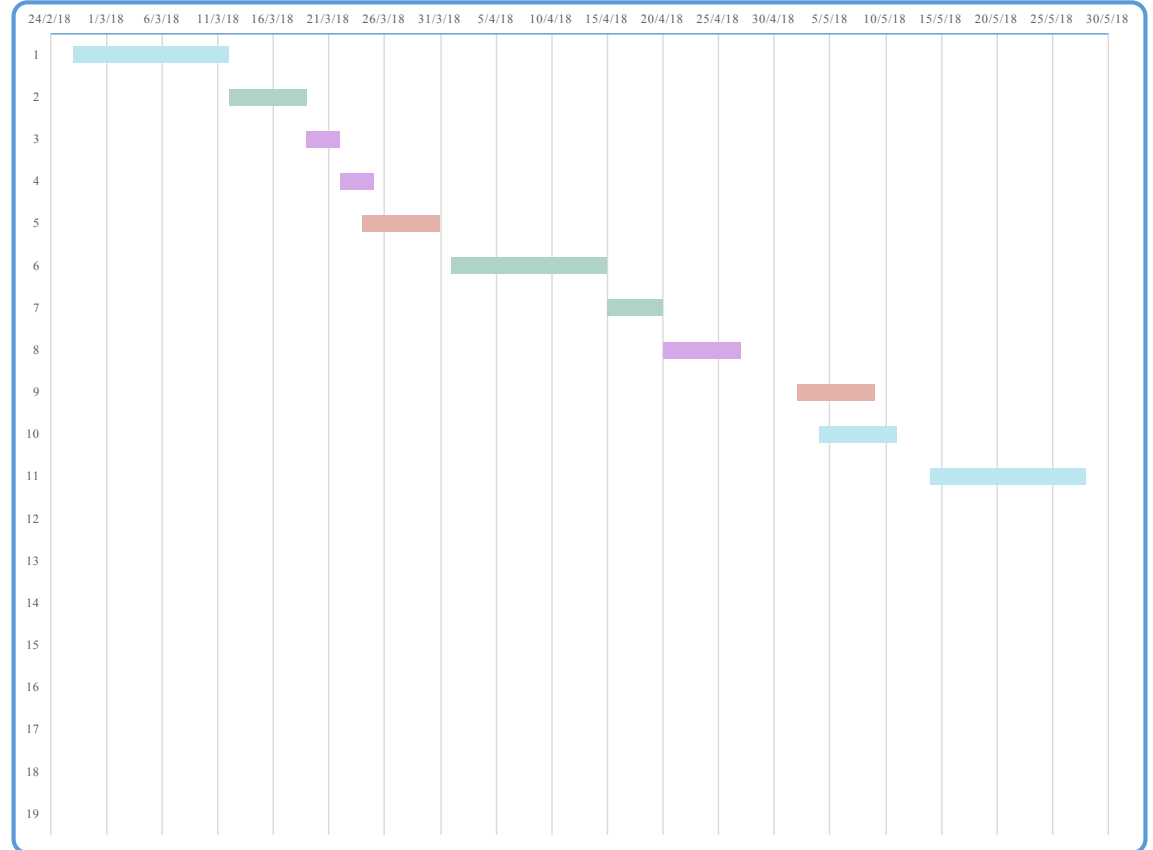

10.18

QFD Chart: Solar Powered Autonomous Raft (SPAR)

Written by: Johnathon Borella

		Engineering Characteristics (1,3,9)									
Client Requirements	Relative Importance (1:5)	Dimensions (m)	Weight (kg)	Cost (AU\$)	Power (KW)	Velocity (m/s)	Testing distance (m)	Reliability(%)	Time to set up (min)	Test cycle (min)	Expected life (yr)
Integrity & Sustainability	5	3	9	9	3	1	9	9		9	9
Bouyancy, drag and weight dist.	5	9	9	3	9	9	1	3		1	3
Cost & Feasibility	4	3	3	9	3	3	3	9		3	9
Australian & Marine Standards	3					1	3	1			1
Safe to Operate & Handle	3	3	3	1	3	3	1	9	3	3	1
Integrates with other systems	4	9	1	3	1	3	9	1	3	1	1
Modular Design	4	3	9	3	1	3	3	3	3		3
Testing	3	1	3	1	3	3	3	9	3	3	1
Documentation	1	1	1	1	1	1		3	3	3	3
Technical Drawings & Models	2	3	1	1	1	1	1	1	1	1	3
Absolute Importance	315	35	39	31	25	28	33	48	16	26	34
Relative Importance	100%	11%	12%	10%	8%	9%	10%	15%	5%	8%	11%
Rank Order	10	3	2	6	9	7	5	1	10	8	4

Engineering Characteristics Results	
1 Reliability(%)	6 Cost (AU\$)
2 Weight (kg)	7 Velocity (m/s)
3 Dimensions (m)	8 Test cycle (min)
4 Expected life (yr)	9 Power (KW)
5 Testing distance (m)	10 Time to set up (min)

10.19 Thesis Report Electric Block Diagram

