

Drive line design and implementation for REV Formula SAE electric vehicle

Graham N. Lionnet

20686571

School of Mechanical and Chemical Engineering
University of Western Australia

Supervisor: Adam Wittek

School of Mechanical and Chemical Engineering
University of Western Australia

Co-Supervisor: Thomas Braunl

School of Electrical, Electronic and Computer Engineering
University of Western Australia

Thesis

**School of Mechanical and Chemical Engineering
University of Western Australia**

Submitted: October 28th 2013

Project summary

This thesis project outlines the design of a drive line system for the formula SAE (Society of Automotive Engineers) competition. The vehicle is to participate in an event scheduled by the formula SAE in Melbourne in December 2013. The car must have a reliable drive line in order to complete the race weekend. After an initial failure of the drive line implemented in the car in 2012, the system needs to be evaluated to identify which components must be re-designed, manufactured and implemented into the existing system. The designs must adhere to the regulations distributed by the FSAE, while being cost effective and competitive.

The designs in this thesis are machined and implemented into the existing 2013 REV (Renewable Energy Vehicle) FSAE vehicle at the University of Western Australia.

Letter of Transmittal

Graham N. Lionnet
49Hodgson street
Tuart Hill, WA, 6060

Associate Professor Adam Wittek
Faculty of Engineering, Computer and Mathematics
University of Western Australia
35 Stirling Highway
Crawley, WA, 6009

Dear Associate Professor Wittek

I hereby submit this thesis, entitled, Drive line design and implementation for REV Formula SAE electric vehicle, as part of the requirement for the degree of Bachelor of Engineering

Yours Sincerely

Graham Lionnet
20686571

Acknowledgements

I would like to acknowledge the continued support and guidance of Associate Professor Adam Wittek as my supervisor. His contributions to the project have been invaluable.

I would also like acknowledge Dr. Thomas Braunl for his knowledge and support as the REV Projects supervisor and as my Co – Supervisor.

I would also like to acknowledge the engineering workshop technicians, Ken Fogden and Mark Henderson for their insight into manufacturing of parts.

Lastly I would like to acknowledge several students who have each benefitted off each others effort throughout the year; Jameson Wedge, Carl Conquilla and Hayden Ford.

1 CONTENTS

2	Introduction	7
2.1	Electric Vehicles and REV team	7
2.2	Thesis Goals	7
2.3	Thesis Overview	7
2.4	Initial failure modes	8
3	Drive shaft design	10
3.1	Original drive shaft	10
3.1.1	Load requirements for drive shaft	10
3.1.2	Load calculations	11
3.1.3	Calculation of shaft diameter	21
3.2	Design of new Driveshaft	24
3.2.1	Preliminary design options	24
3.2.2	Method of attaching hub to driveshaft	25
3.2.3	Method of transferring torque from drive shaft to hub	26
3.2.4	Verification of drive shaft design	31
3.3	Drive shaft bearing selection	37
3.3.1	Current drive shaft Bearings	37
3.3.2	Loads on bearings	38
4	Hub Design	39
4.1	Original hub	39
4.2	Design parameters for hub	40
4.2.1	Weight reduction of hub	40
4.2.2	Final design and manufacture method	43
4.3	Spur gears	43
4.3.1	Analysis of spur gear, and pinion teeth	44

5	Motor drive shaft	45
5.1.1	Data from verification of drive shaft	46
5.1.2	Calculation of forces on pinion gear.....	46
5.1.3	Selection of Stress factors.....	47
5.1.4	Alternative system layouts.....	50
6	Cost.....	52
7	Conclusion.....	52
8	References	53
9	Appendices	55
9.1	Stress raising factor graphs.....	55
9.1.1	Size factor	55
9.1.2	Correction factor.....	55
9.1.3	Stress raising factor K for stepped shaft.....	56
9.1.4	Stress raising factor K for splined shaft.....	56

2 INTRODUCTION

2.1 ELECTRIC VEHICLES AND REV TEAM

The Renewable Energy Vehicle (REV) team was founded by Professor Thomas Braunl and Dr Kamy Chang in 2008. Previous successful projects include electric conversions of road cars, specifically a Hyundai Getz and Lotus Elise.

Currently there are three electric projects being undertaken which include the FSAE 2013 race car for which this thesis is written, an electric jet ski and an autonomous vehicle using a previous race car.

2.2 THESIS GOALS

The main purpose of this thesis is to redesign the drive line system for the formula SAE vehicle for better reliability and compliance with regulations. Each component is required to undergo an assessment to ensure the parts reliability and performance, then parts which do not meet the required standards are to be redesigned and implemented into the current vehicle.

2.3 THESIS OVERVIEW

The renewable energy vehicle team (REV) is a student oriented operation and as such is a learning experience for all those involved. This leads to some innovative designs and some exceptional work, though it does however lend itself to some clinical errors. With the current car, there were immediate errors found in the design of many of the working components. These errors led to poor reliability and performance of the vehicle.

This thesis outlines identification of these errors within the drive line system of the vehicle and the process of eliminating them. This includes comprehensive evaluation of components, redesigning the components and risk assessment in case of future failure.

Assessment of existing components is done with driving tests, then scrutinized in final element analysis to find economically viable solutions to the identified design flaws, then manufactured and implemented into the current car.

The system is then analyzed using a failure modes ad effects analysis (FMEA) to identify potential means of failure and to rank them on their severity, probability of occurrence and

ease of detection (dayadem 2003). This is a safety issue and is critical in justifying allowing our students to race the vehicle, as well as setting a maintenance system to keep the car operational for the future.

The drive line, for our purposes, is the mechanism by which the power generated by the motors is transferred to the ground. This is done mechanically via two drive shafts, two gears, a hub and a wheel in each assembly all mounted to an upright. There are four motors in the vehicle, one in each wheel hub, therefore four of these systems. The systems are identical for each wheel, the left and right sides being mirror images of each other.

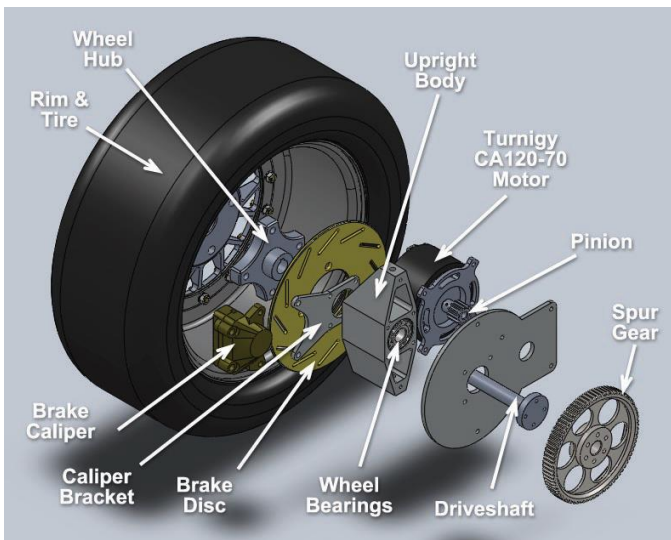

Figure 2, exploded view of original system (REV team 2012/2013)

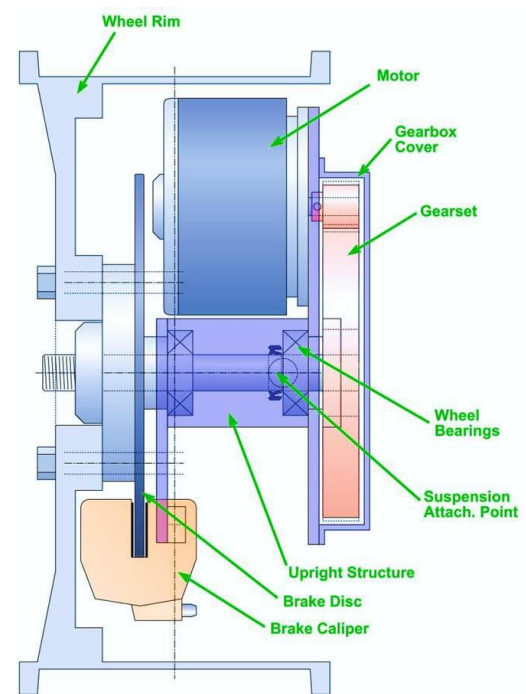

Figure 1, diagram of components (REV team 2012/13)

The figure above shows the general layout of the system used in the car at the beginning of 2013. On the first day of testing of the vehicle, the drive line failed.

2.4 INITIAL FAILURE MODES

During a test run it was seen that the wheels of the car were not rotating in a single plane. This was accompanied by a grinding noise and the vehicle was stopped. Upon inspection it

was observed that the end bolts in the drive shaft had come loose. This was designed as below

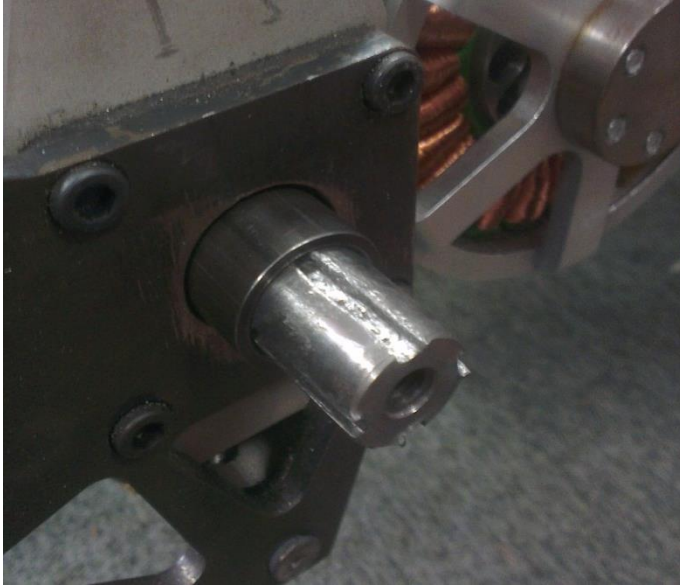

Figure 3, damaged key ways and bolt thread

This is a single bolt holding the entire hub assembly onto the drive shaft. The thread within the drive shaft was damaged and the bolt had loosen. Furthermore, this does not comply with the FSAE regulation T11.2.1 *'All critical bolt, nuts, and other fasteners on the steering, braking, driver's harness, and suspension must be secured from unintentional loosening by the use of positive locking mechanisms. Positive locking mechanisms include:*

- *Correctly installed safety wiring*
- *Cotter pins*
- *Nylon lock nuts*
- *Prevailing torque lock nuts'* (2013 FSAE rules)

Therefore the use of the bolt for this purpose was deemed unsuitable. An alternative is required.

It can also be seen in the image (image 2 above) that the keyways used to transfer the torque from the drive shaft to the hub are damaged. All the drive shafts were then removed and inspected. They all had similar damage, which after only a few minutes of operation showed they were insufficient to transfer the loads required.

The rest of the system was checked for visible damage but none was found. Though they are to be scrutinized in this thesis.

3 DRIVE SHAFT DESIGN

3.1 ORIGINAL DRIVE SHAFT

The old drive shaft was constructed out of 1020, low carbon mild steel. It transferred torque from the gear end via six, 8.8 Metric grade M5 bolts and four 1.5mm deep key ways were used to transfer the torque to the hub.

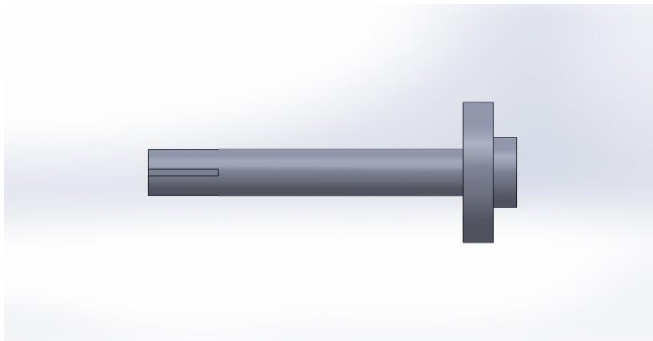

Figure 5, side view of original drive shaft

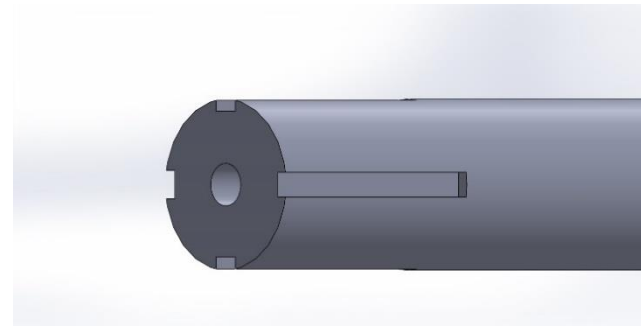

Figure 4, close up of keyways and internal thread

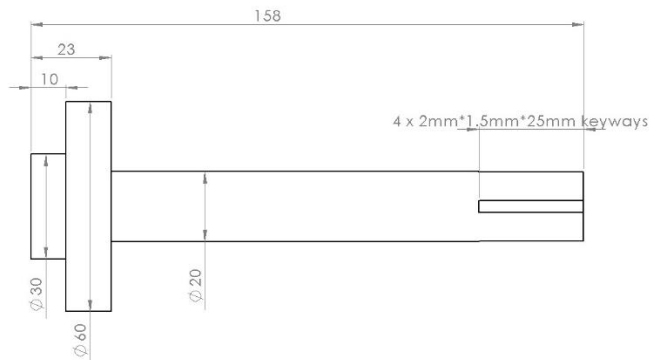

Figure 6, dimensions of original drive shaft

3.1.1 Load requirements for drive shaft

The hub drive assembly for the vehicle is required to both support the weight of the car during racing conditions and transfer the power from the 15kW motor to the wheels of the

vehicle. It must do this with minimal losses and efficient costs. The loads acting on the shaft are predominantly from the torque from the motor. These loads are calculated as below according to the Australian standards AS1403-2004 rotating steel shafts.

3.1.2 Load calculations

The driveshaft must maintain its structural integrity at the most critical loads. These are calculated as below.

During operation, the radial loads will be due to the vertical loads on the car, or rather the loads perpendicular to the surface of the tire. These loads will be maximum at peak acceleration/deceleration and at peak cornering speeds.

Load experienced by the wheels due to lateral or transverse acceleration can be calculated by the following formula. (fltechnical:suspension, 2009)

$$dW = \frac{m * h * a}{t}$$

Where,

dW = Total weight transfer due to an acceleration a

a = Acceleration (m/s²)

m = Total mass of vehicle (kg)

H = Height of centre of gravity (m)

t = Track width (m)

Below are the current dimensions of the 2013 UWA Formula SAE Electric Vehicle.

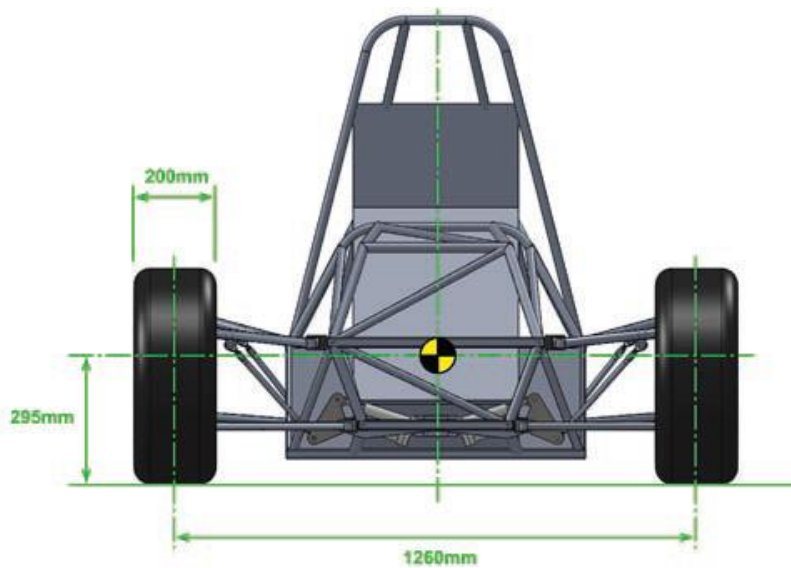

Figure 7, 2013 SAE front view (FSAE team 2012/13)

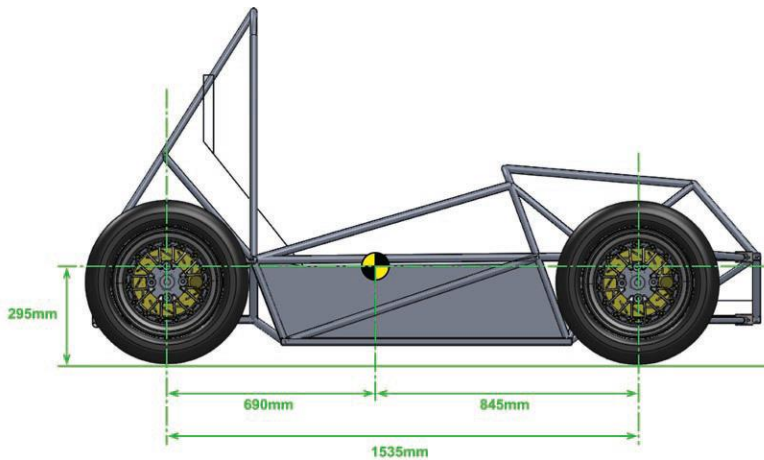

Figure 8, SAE car side view (FSAE team 2012/13)

The vehicle has been measured to weigh, 287.3 kg currently. Adding a driver of mass 100kg we have a total mass of roughly 390 kg. Therefore at a static state, assuming a 50/50 weight distribution we have $390/4 = 97.5\text{kg}$ on each wheel. Assuming a maximum cornering and/or breaking acceleration of 1.3G for the racing tires equipped on the vehicle, the maximum load transfer for the vehicle is calculated below.

Cornering:
$$dW = \frac{390 \cdot 0.295 \cdot (9.81 \cdot 1.3)}{1.26} = 1164.47\text{N}$$

Therefore the increased weight on each wheel is $\frac{1164.47}{2} = 582.235\text{ N} = 59.35\text{ kg}$

The maximum vertical load during cornering on each wheel is thus

$$59.35 + 97.5 = 156.85kg$$

This will be on the outside wheels, while the inside wheels will experience a vertical load each of

$$97.5 - 59.35 = 38.15 kg$$

Braking: $dW = \frac{390*0.295*(9.81*1.3)}{1.535} = 955.852N$

Therefore the increased weight on each wheel is $\frac{955.892}{2} = 477.93 N = 48.718 kg$

The maximum vertical load during breaking is thus

$$48.718 + 97.5 = 146.218kg$$

This will be on the front wheels, while the back wheels will experience a vertical load of

$$97.5 - 48.718 = 48.782 kg$$

For simplicity, the notation is standardized below.

3.1.2.1 Notation

D = minimum calculated diameter of shaft at cross-section under consideration, in millimetres

F_R = endurance limit of shaft material = 0.45 F_U

F_s = safety factor

F_U = tensile strength of shaft material, in megapascals

F_Y = yield strength of shaft material, in megapascals

I = rotational mass moment of inertia of a shaft and its associated rotating and linear components, in kilogram metres squared

K = stress-raising factor

K_s = size factor

M_q = bending moment at shaft cross-section under consideration, in newton metres

N = rotational full-load speed of driving or braking medium, in revolutions per second.

T_q = maximum torque at shaft cross-section under consideration, in newton metres

T_M = torque applied to the mechanism by the braking or driving means or by the external load, in newton metres

3.1.2.2 Data for relevant calculations

Motor: Turnigy CA120-70

Maximum Power = 15kW

speed = 117.6 revolutions/sec

Gears: Reduction ratio = 6.7:1

Efficiency = 99%

Material: Plain carbon steel

Tensile strength $F_U = 500\text{MPa}$

Endurance limit $F_R = 0.45 F_U = 225\text{ MPa}$

Yield strength $F_Y = 350\text{ MPa}$

3.1.2.3 Relevant equation selection

The Australian standard requires a selection of a relevant equation for minimum diameter of a shaft.

Since the number of mechanism starts per year are less than 600 and the number of revolutions per year are greater than 900 we will go with equation 2, in table 2 of AS1403-2004-Rotating-steel-shafts standards. That is,

$$D^3 = \frac{10^4 F_S}{F_R} \sqrt{\left[K_S K \left(M_q + \frac{P_q D}{8000} \right) \right]^2 + \frac{3}{4} T_q^2}$$

Tensile strength of mild steel is approximated as 400MPa (Beardmore, 2012)

3.1.2.4 Rotational Speeds

Motor shaft attached directly to motor, therefore rpm of shaft = rpm of motor

$N=N_1=117.6\text{ r/s}$

$$N_2 = N_1 / \text{gear ratio} = 117.6 / 6.7 = 17.552 \text{ r/s}$$

3.1.2.5 Moments of inertia for motor shaft (shaft 1)

Primary drive shaft = $(mr^2)/2$ for two sections, r being the radius of each section (5mm and 17 mm respectfully) and m the mass of the sections. Mass of primary shaft = 264g using density of 7.85 g/cm³.

$$\text{Motor shaft moment of inertia} = 2.96 \times 10^{-5} \text{ kgm}^2$$

$$\text{Moment of inertia for motor} = 4.48575 \times 10^{-3} \text{ kgm}^2$$

$$\text{Moment of inertia pinion gear} = 1.264 \times 10^{-5} \text{ kgm}^2$$

$$\text{Total moment of inertia for shaft 1} = \mathbf{4.528 \times 10^{-3} \text{ kgm}^2}$$

3.1.2.6 Moment of inertia for drive shaft (shaft 2)

$$\text{Moment of inertia drive shaft} = 1.59 \times 10^{-4} \text{ kgm}^2.$$

$$\text{Moment of inertia spur gear} = 1.01777 \times 10^{-3} \text{ kgm}^2$$

$$\text{Moment of inertia wheel} = 0.1914735 \text{ kgm}^2$$

$$\text{Moment of inertia hub} = 4.69125 \times 10^{-4} \text{ kgm}^2$$

$$\text{Total moment of inertia for shaft 2} = 0.19315 \text{ kgm}^2$$

3.1.2.7 Torque calculations

Tests done by Ian Hooper (DEVELOPMENT OF IN-WHEEL MOTOR SYSTEMS FOR FORMULA SAE ELECTRIC VEHICLES, 2012) for the motors showed our maximum, full load rotation speed is 7056 rpm @ 48 Volts. This is 117.6 revolutions a second

$$\text{Rated motor power} = \frac{2\pi N \text{ * rated torque}}{1000} \text{ (kW)} \text{ (Standards1403, 2011)}$$

$$\text{Therefore the rated torque} = (1000 * 15) / (2 * \pi * 117.6) = 20.3 \text{ Nm.}$$

Since this is a DC motor, the value of the max torque is 1.5 * rated torque, though this has already been compensated for in the specification given for max power by the manufacturer.

3.1.2.8 Angular acceleration

From table one of the Australian standards, AS1403, the equation for finding the output torque through one set of spur gears is given as;

$$T_2 \text{ output} = (T_M - I_1 \alpha)(N_1/N_2)\eta - I_2(N_1/N_2)\alpha$$

The output torque must be equal to the load torque from the hub to the splines.

3.1.2.8.1 Output torque requirements

The maximum torque the shaft is subjected to will be during heavy braking. The maximum load on a wheel during braking is $146.218kg$, or $1434.399N$

The coefficient of friction between car tire rubber and asphalt is 0.72 (Engineering tool box, n.d.)

Friction force = Normal force * coefficient = $1032.77N$ acting tangential to the contact patch of the wheel and the asphalt.

The torque load is then $T_M = 1032.77 * 0.26(\text{radius of wheel}) = 268.52Nm$.

Substituting this into the equation above we obtain

$$268.52 = [(20.3 - 4.528 \times 10^{-3} \alpha) * 6.7 * 0.99] - (0.19315 * 6.7) \alpha$$

$$\alpha = 101.1 \text{ rad/s}^2$$

Drive shaft (shaft 2) Input torque = $(T_M - I_1 \alpha)(N_1/N_2)\eta = \mathbf{127.559Nm}$

3.1.2.9 Calculation of forces arising at the gears and reactions arising at the bearings for drive shaft

Tangential force at spur gear $F_T = \frac{\text{torque being transmitted}}{\text{Pitch diameter}/2}$ (Standards1403, 2011)

$\text{Pitch diameter} = \frac{\text{Outside diameter} * \text{Number of teeth}}{\text{Number of teeth} + 2}$ (Wright, 2001)

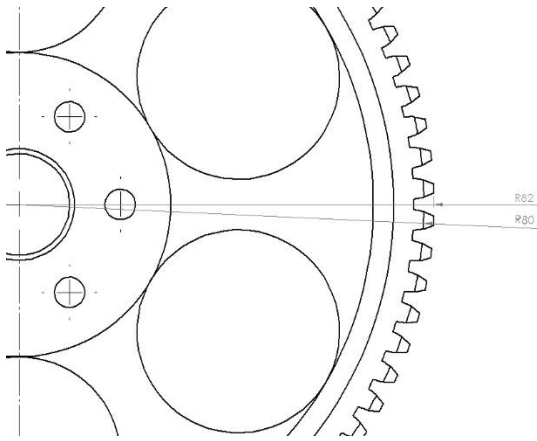

Figure 9, Spur gear diameter

$$= \frac{164 * 80}{(80 + 2)} = 160\text{mm diameter} = 80\text{mm radius}$$

The calculated and designed diameters are equal.

Therefore the tangential force on the spur gear is $127.559(\text{Nm})/0.080(\text{m}) = 1594.4875\text{N}$

Separating forces at the gear

$$\cos(\text{pressure angle}) = \frac{\text{base diameter}}{\text{pitch diameter}} \text{ (Wright, 2001)}$$

Normal pressure angle for spur gear = 12.84 degrees

$$\text{Radial force at the wheel } F_r = F_T * \frac{\tan(\text{normal pressure angle})}{\cos(\text{perpendicular pressure angle})} \text{ (Standards1403, 2011)}$$

The spur gear is a straight cut gear, so the perpendicular pressure angle = 0 ($\cos 0=1$) Giving the radial force on the gear = **363.43N**

3.1.2.10 Force diagram for drive shaft

The force from the hub is taken to act at the end of the spacer between the hub and the outside bearing, giving the total effective length of the shaft as 111mm.

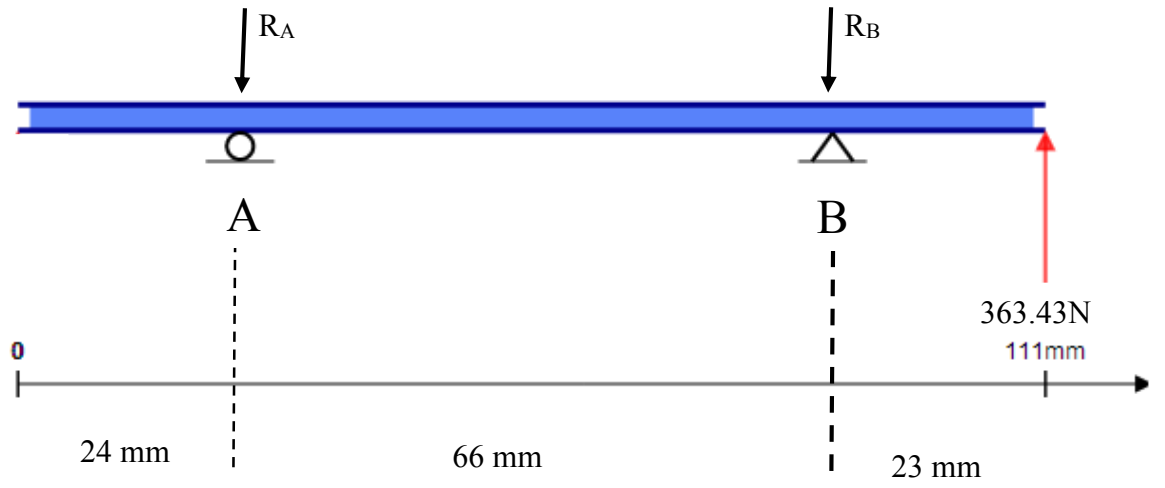
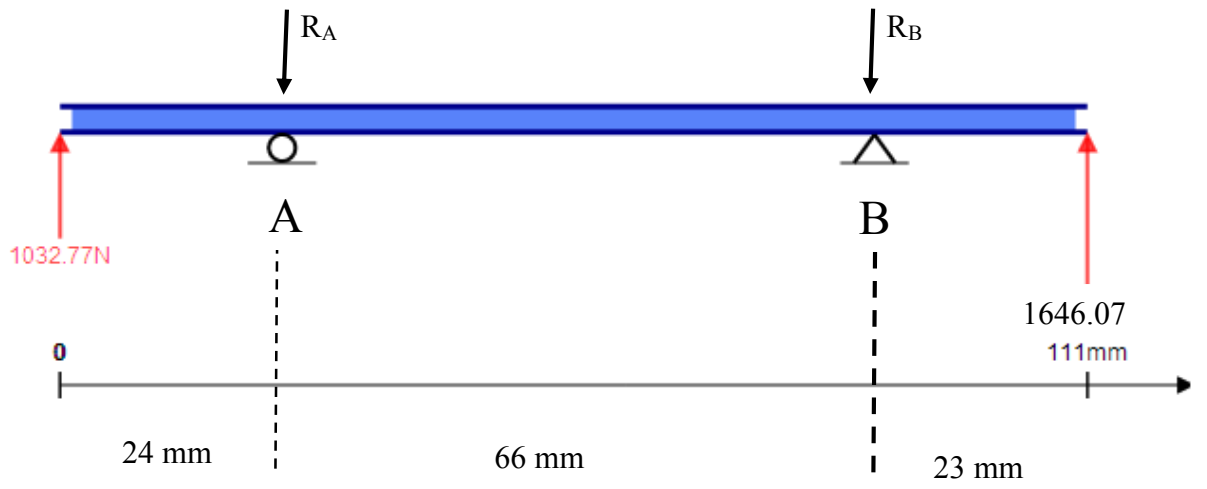

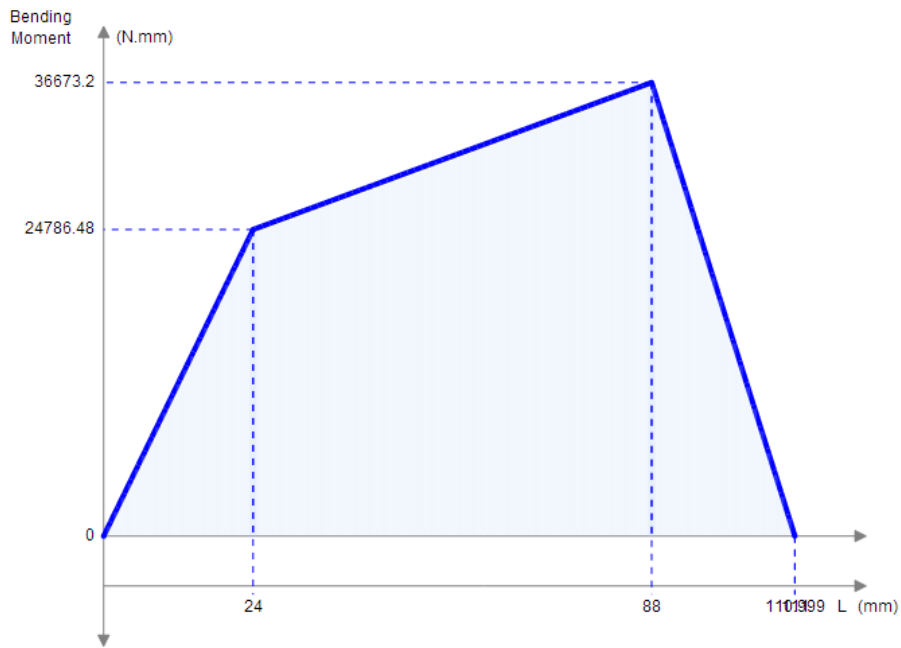

Figure 10, x-axis bending moment diagram

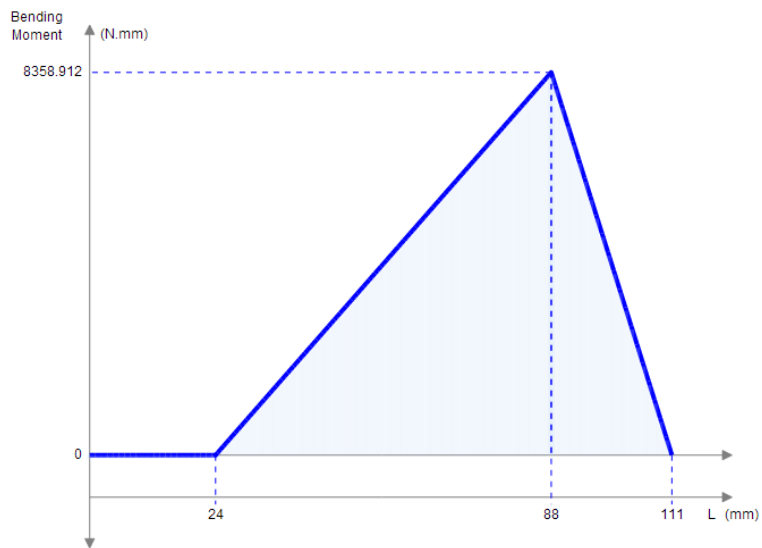

Figure 11, y-axis bending moment diagram

$$\text{Total bending Moment } M_q = \sqrt{M_x^2 + M_y^2} = 37.6136\text{Nm}$$

3.1.2.11 Radial force

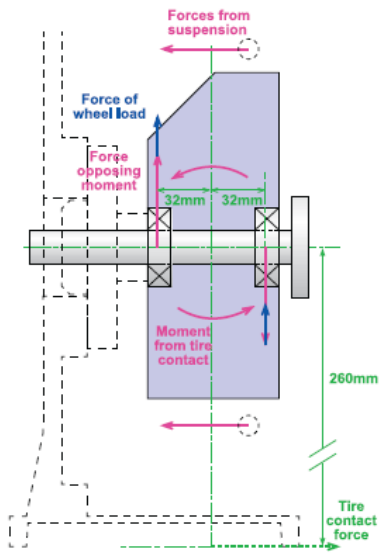

Figure 12, diagram showing moment generation on shaft (REV team 2012/13)

The moment acting due to the side loading of the tires acts directly on the side of the bearing. The equal and opposite reaction will occur on the bolt securing the hub to the drive shaft, which applies an axial load on the drive shaft

The tire contact force is calculated using the cornering load found before (156.85kg) and the coefficient of friction between tire rubber and asphalt of 0.72 (Engineering tool box, n.d.). The summation of these two values gives the tire contact force of **1107.863N**

This creates a moment of 288Nm acting on the side of the bearing and the thread of the bolt. The distance between these two points is 46mm. Therefore the force opposing this motion is

$$P_q = \frac{288}{\left(\frac{0.046}{2}\right)} = 12521.74N$$

3.1.3 Calculation of shaft diameter

3.1.3.1 Selection of various factors

3.1.3.1.1 Size factor K_s

Shaft diameter at the point of interest is 20mm. This is at point B shown on bending moment diagrams and location of inner bearing. The size factor is selected from the following graph.

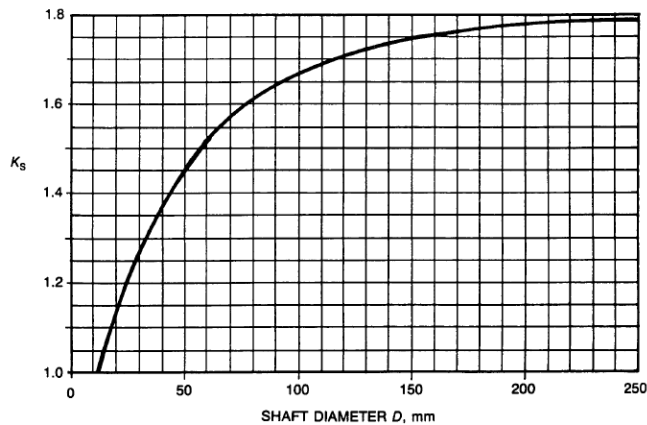

Figure 13, Size factor chart (Standards1403, 2011)

The value of 1.3 was selected for K_s

3.1.3.1.2 Geometry factor K

The shaft is splined and has a step in diameters. According to clause 8.2(d) both effects must be considered together. (Standards1403, 2011)

(i) Correction factor

$D_1/D_2 = 30/20 = 1.5$ Therefore correction factor, Δ selected from the chart = 0.03

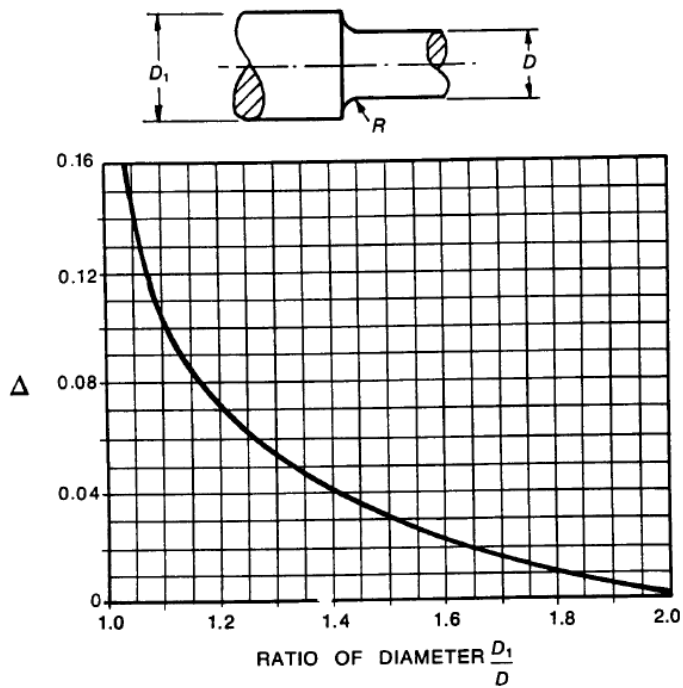

Figure 14, correction factor chart (Standards1403, 2011)

(ii) Calculation of Z

$$Z = \frac{R}{D} + \Delta = \frac{0.5}{20} + 0.03 = 0.055$$

Where R is the parameter shown in figure 13 above.

(iii) Selection of K for step

From the graph below, the value of K(step) was selected as 1.8

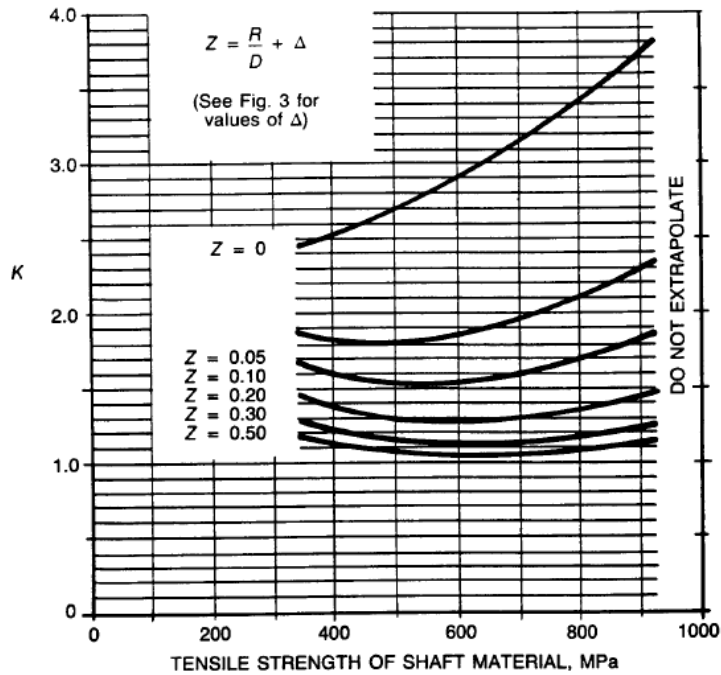

Figure 15, $K(\text{step})$ graph (Standards1403, 2011)

(iv) Selection of K for splines

From the graph below, the value of K (splines) was selected as 1.95 for the parallel splines in the original shaft

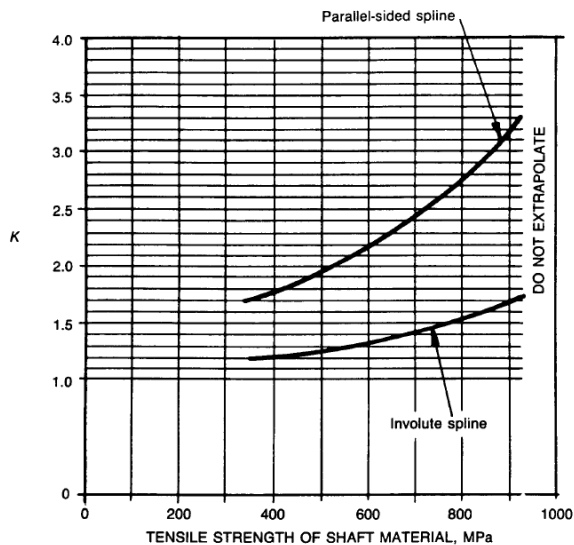

Figure 16, $K(\text{spline})$ graph (Standards1403, 2011)

According to clause 8.2(d), (Standards1403, 2011)

Final geometry factor $K = K_{\text{spline}} + (0.2 * K_{\text{step}}) = 2.31$

3.1.3.2 Minimum diameter of original driveshaft

Substituting all of the values from above into the selected equation we get;

$$D^3 = \frac{10^4 * 2}{(0.45 * 500)} \sqrt{([1.3 * 2.31 \left(37.6136 + \frac{12521.74 * 20}{8000} \right)]^2 + 0.75 * 127.559^2)}$$

Using a safety factor of 2,

$D = 27.525\text{mm}$. This is much greater than the original diameter of the shaft. Therefore we must consider a new design.

3.2 DESIGN OF NEW DRIVESHAFT

In order to reduce the cost of the new system a design for a drive shaft that allows the use of the existing components is crucial. The new design is therefore limited to a maximum diameter at the bearings of 20mm, though can be increased at other points along the shaft. The shaft must however be able to slide through the bearing from one direction, meaning that one side of the shaft must have a maximum diameter of 20mm.

This leaves two options.

- 1) Diameter increased on the gear end as before

This requires a system of attaching the hub and transferring torque from the drive shaft to the hub.

- 2) Diameter increased on the hub end.

This requires a system of attaching the gears and transferring the torque from the spur gear to the drive shaft. Also requires method of attaching hub to the drive shaft.

3.2.1 Preliminary design options

- 1) Large diameter at the gear end.

Advantages	Disadvantages
Allows re-use of method of mounting spur gear on the drive shaft	Requires new hubs to be machined

Easily removal of hub for maintenance	Method of attaching new hub must be designed
	Method of transferring torque to hub must be designed

2) Large diameter at hub end

Advantages	Disadvantages
Can re-use old hubs if welded onto shaft	Method of mounting spur gear must be designed
	Method of transferring torque must be designed
	Difficult to remove hub as the gear cover must first be removed and then the gear to remove shaft and hub.

After consulting with specialists at WAGears and EVWorks, two machining companies in Perth. It was advised that using the old hubs would be difficult as the alignment when attaching the hub to the drive shaft would be crucial and very difficult to achieve when welding.

This removes one advantage for changing the design from the original. Secondly, the cost of each hub was \$20, while the cost for the spur gear is \$300. So the design for the spur gear was decided to remain unchanged as it is the most economical option.

3.2.2 Method of attaching hub to driveshaft

The original design used a singular bolt M8 bolt. The force on the thread $=P_q$ from min. diameter calculations = 12521.74N. This caused the internal thread in the end of the drive shaft to be damaged. The decision to design a hub that can be removed from the drive shaft gives us few options but to use an end nut that can be removed.

Due to the dimensions of the drive shaft with a maximum diameter of 20mm on the hub side of the drive shaft and allowing for the recess in the splines, the largest standard

external thread that could be used is an M16x2 thread. According to the regulations a grade 8.8 nut will be used. (SAE, 2013)

Using minor diameter of 14.21mm and pitch diameter of 14.913 according to information from BS EN ISO 898 to calculate the stress area and using the tensile strength of 800MPa for grade 8.8 nuts (carbon steel quenched and tempered).

The bolt ultimate strength = **125334N >> 12521.74N required**

2.5 mm from the end of the thread, there is a 2mm diameter hole drilled through the drive shaft. This is to attach a cotter pin as per the regulations. (SAE, 2013). Note the thread not shown in software used (SolidWorks 2013)

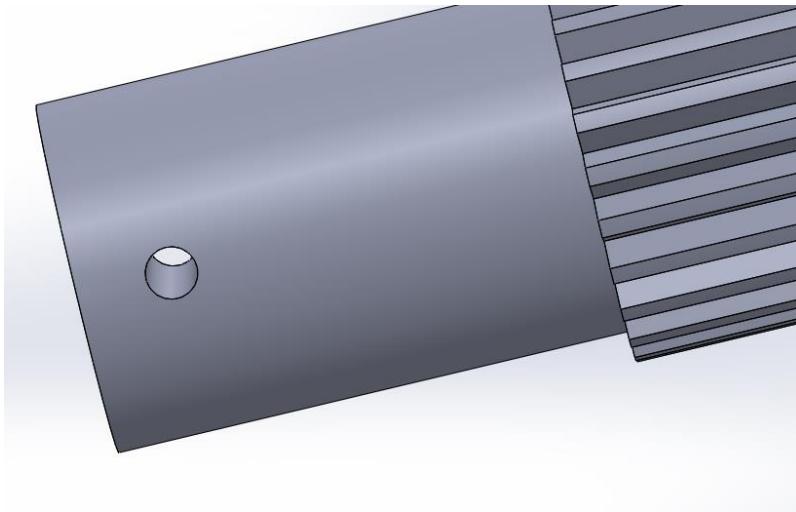

Figure 17, close up of cotter pin hole

3.2.3 Method of transferring torque from drive shaft to hub

Since the hub must be removed in order to install the drive shaft splines are the best option for transferring the torque as new hubs are being made which can be designed with splines fitted splines.

For the selection of the splines to be used on the shaft we contacted WAGears who are an independent shaft splining and gearing company in Perth, Australia use DIN5482 standards (Deutsche Normen). They recommended a 12 spline 20 x 17mm dimensions.

WAGears provided the lowest quote for the machining of the splines of the three companies approached.

3.2.3.1 Verification of Splines and material selection

ISO straight involute spline capacity can be calculated using various factors and formulas written in various international standards. Using ISO 14 and ISO 4156 the 12 x 20 x 17 DIN5482 splines are assessed.

Notation for this part

D = Pitch diameter of spline (m)

m = spline module (m)

t = Tooth thickness (m)

z = Number of teeth

L_e = Effective Length of spline = Straight Length (m)

h = Depth of engagement of spline teeth

T = Applied Toque (N.m)

K_s = Service factor

σ_c = resulting compressive stress in shaft material (N/m²)

τ = resulting shear stress in shaft material (N/m²)

3.2.3.1.1 Shear stress at pitch diameter of spline.

$$\tau = \frac{4TK_s}{DztL_e}$$

3.2.3.1.2 Compressive stress on teeth

$$\sigma_c = \frac{2TK_s}{DzhL_e}$$

3.2.3.1.3 Involute 12x20x17 DIN5482 spline calculation.

Dimensions (Normen, 1973)

Outside diameter = 20mm

Pitch diameter, D = 19.2mm

module, m = 1.6

Number of teeth, z = 12

chamfer radius, $c = 0.25\text{mm}$

Other parameters, (Beardmore, 2012)

L_c : length of splines section = 23mm

D_r : reduced diameter = $m(z-1.5) = 16.8\text{mm}$

D : Pitch diameter = $m \cdot z = 19.2\text{ mm}$ (given in dimensions),

p : Pitch = $m \cdot \pi = 5.026548\text{mm}$

t : tooth thickness = $p/2 = 2.513274\text{mm}$

h : tooth height = $0.9m = 1.44\text{mm}$

Calculation of service factor K_s

Where the service factor must be calculated from relevant factors according to the application of the spline.

i) Design factor

It is assumed that the hub/drive shaft have a closed fit, such that during operation there is no relative movement due to the use of a shaft nut.

Therefore the Design factor is 1

ii) Application factor

The power source for the car is a motor with intermittent shock loads during rapid changes of throttle position. This gives an application factor of 1.5

iii) Load misalignment factor

It is assumed that there will be minimal misalignment with the spline ($< 0.004\text{ mm/mm}$) so the Load misalignment factor = 1

iv) Fatigue factor

The number of stop start cycles for the drive shaft for its lifetime assuming that the car is only run during test days and event days estimated at around 100 000. The load is fully reversed so the fatigue factor = 0.4

v) Life wear factor

The number of revolutions of the shaft can be calculated using the average speed of the car around the track. Average speed is to be 48km/hr (SAE, 2013). The radius of the wheel is 0.26m. giving our rolling circumference as $2 * \pi * 0.26 = 1.633628\text{m}$

In order to travel 48 km in one hour, the tire must rotate $48000/1.634 = 29382.451$ rotations/hr

Assuming 1000 hours of operation, this is 29382451 rotations

This gives a wear life factor of 1.0

Service factor is thus; Spline application factor/fatigue factor = $1.5/0.4 = K_s = 3.75$

Shear stress in spline teeth

$$\tau = \frac{4 * 127.56 * 3.75 * 1000}{16.2 * 12 * 2.513 * 23} = 170.29\text{MPa}$$

Compressive stress in spline teeth

$$\sigma_c = \frac{2 * 127.56 * 3.75 * 1000}{16.2 * 12 * 1.44 * 23} = 148.59\text{MPa}$$

The value for the Torque in these calculation coming from the torque calculated through the Australian standards for rotating steel shafts, (Standards1403, 2011) of 127.56 Nm.

3.2.3.2 Material Selection

Material	Hardness		Ultimate Tensile Strength	Permissible Compressive Strength	Permitted Shear Strength
	Binnell	Rockwell C	MPa	MPa	MPa
Structural Steel	150-200	-	350	90	140
Carbon Steel	220-270	-	500	130	200
Alloy Steel	300-350	33-38	600	200	275
Surface Hardened Steel	650	45-53	650	250	275
Cast Iron (Spheroidal Graphite)	400	-	400	135	140

Figure 18, general steel properties (Beardmore, 2012)

AS can be seen by the chart above, carbon steel is not adequate for the permissible compressive strength required. Therefore alloy steel will be used. The alloy steel easily available to the company producing the splines is AISI 4140 grade steel with the properties listed below.

Brinell hardness	320
Tensile strength, ultimate	1140 MPa
Tensile strength, Yield	965 MPa
Modulus of elasticity	205 GPa
Bulk Modulus	140 GPa
Poissons Ratio	0.29
Shear modulus	80 GPa

Figure 19. AISI 4140 material properties (MatWeb, 2013)

Therefore it is concluded that for 12x20x17 DIN 5482 splines, AISI 4140 is a suitable material as the hardness is in the range required (300- 350 brinell hardness) and the ultimate tensile strength is greater than required. (1140 MPa > 600 MPa).

Therefore AISI4140 steel will be used for both male and female splines. That is, both the drive shaft and the hubs will be made from the same grade steel.

3.2.3.3 Reducing moving parts

The original design has two spacers which press up against either sides of the bearings such that a 9mm spacer rested against the inner bearing and the spur gear mount while a 24mm spacer rested against the hub and the outer bearing.

In order to reduce the number of components and reduce friction that may occur between these parts, the spacers are to become part of the drive shaft. This can only happen at one end as the shaft must be able to slide through the bearings during installation. Since the drive shaft will have a larger diameter on the spur gear side, this 9m spacer will be replaced by increasing the diameter of the shaft adjacent to the bearing. In order to allow the force through the bearing to act on the largest surface area possible, the diameter of the spacer is made as large as possible.

The bearings used have an inner ring with minimum radius 20mm and maximum radius of 30mm. The spacer will be designed to match these dimensions.

3.2.4.1 Notation

D = minimum calculated diameter of shaft at cross-section under consideration, in millimetres

F_R = endurance limit of shaft material = $0.45 F_U$

F_s = safety factor

F_U = tensile strength of shaft material, in megapascals

F_Y = yield strength of shaft material, in megapascals

I = rotational mass moment of inertia of a shaft and its associated rotating and linear components, in kilogram metres squared

K = stress-raising factor

K_s = size factor

M_q = bending moment at shaft cross-section under consideration, in newton metres

N = rotational full-load speed of driving or braking medium, in revolutions per second.

T_q = maximum torque at shaft cross-section under consideration, in newton metres

T_M = torque applied to the mechanism by the braking or driving means or by the external load, in newton metres

3.2.4.2 Data for relevant calculations

Motor: Turnigy CA120-70

Maximum Power = 15kW

speed = 117.6 revolutions/sec

Gears: Reduction ratio = 6.7:1

Efficiency = 99%

Material: AISI4140

Tensile strength $F_U = 1140$ MPa

Endurance limit $F_R = 0.45 F_U = 513$ MPa

Yield strength $F_Y = 965$ MPa

3.2.4.3 Rotational speeds

The motor is unchanged, so it is assumed that the rotational speeds have not been effected.

The rotational speed of the drive shaft is thus $117.6/6.7 = 17.55224$ revolutions/second.

3.2.4.4 Selection of appropriate formula

This again is unchanged and is equation 2 from the provided table. (Standards1403, 2011)

$$D^3 = \frac{10^4 F_S}{F_R} \sqrt{\left[K_S K \left(M_q + \frac{P_q D}{8000} \right) \right]^2 + \frac{3}{4} T_q^2}$$

3.2.4.5 Moments of inertia

The moments of inertia are all unchanged except for those of the second drive shaft which is longer and has the extra spacer.

Moment of inertia for shaft one (motor shaft, motor and pinion gear) = **4.528x10⁻³kgm²**

Moment of inertia for shaft 2

Moment of inertia drive shaft = 5.05895x10⁻³ kgm²

Moment of inertia spur gear = 1.01777x10⁻³kgm²

Moment of inertia wheel = 0.1914735 kgm²

Moment of inertia hub = 4.69125x10⁻⁴kgm²

Total moment of inertia for shaft 2 = **0.19802 kgm²**

3.2.4.6 Rated motor power

Rated motor torque is unchanged at 20.3 Nm

3.2.4.7 Angular acceleration of shaft 2 (drive shaft)

$$T_2 \text{ output} = (T_M - I_1 \alpha)(N_1/N_2)\eta - I_2(N_1/N_2)\alpha \quad (\text{Standards1403, 2011})$$

The torque load is unchanged as the load on the wheels is unchanged, nor is the friction coefficient. Therefore $T_2 \text{ output} = 268.52\text{Nm}$.

Substituting this in the above equation and all the other values gives $\alpha = \mathbf{98.668 \text{ rad/s}^2}$

This is 2.4316 rad/s² less than previously.

3.2.4.8 Input torque into drive shaft from spur gear

$$T_2 \text{ input} = (T_M - I_1 \alpha)(N_1/N_2)\eta \quad (\text{Standards1403, 2011})$$

Using the values above, T_2 input = **131.686Nm**

3.2.4.9 Calculating force on the bearings

Dimensions of the spur gear are unchanged.

Tangential force $F_T = 131.686/0.08 = 1646.075\text{N}$

Radial force = $F_T \tan 12.84 = 375.18775\text{ N}$

No axial force as the spur gear is straight cut.

3.2.4.10 Bending moments

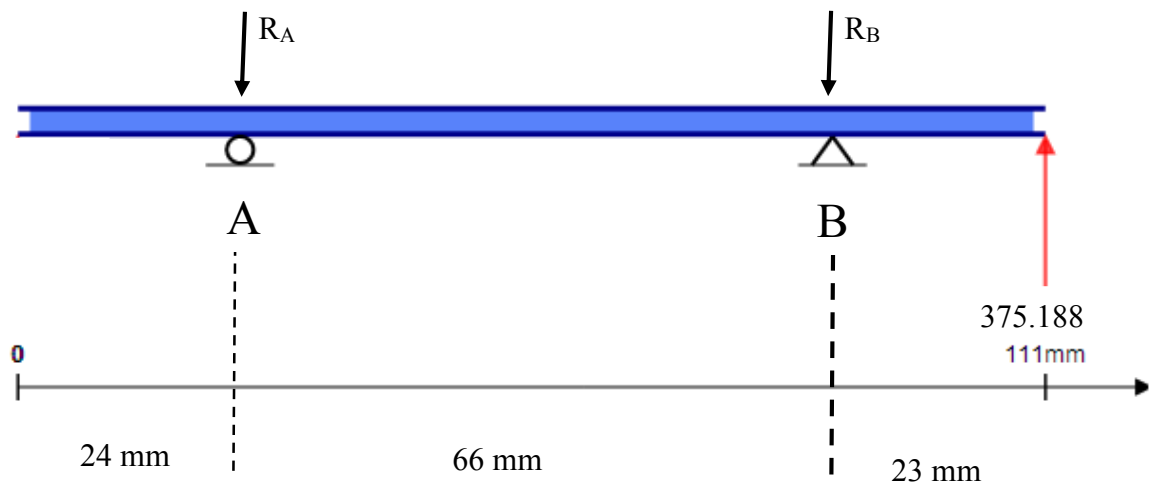
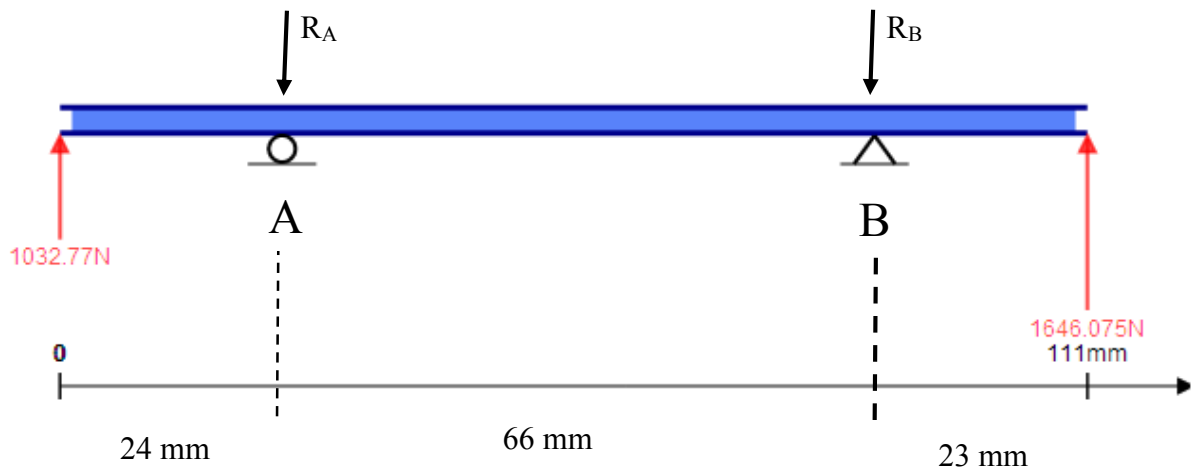

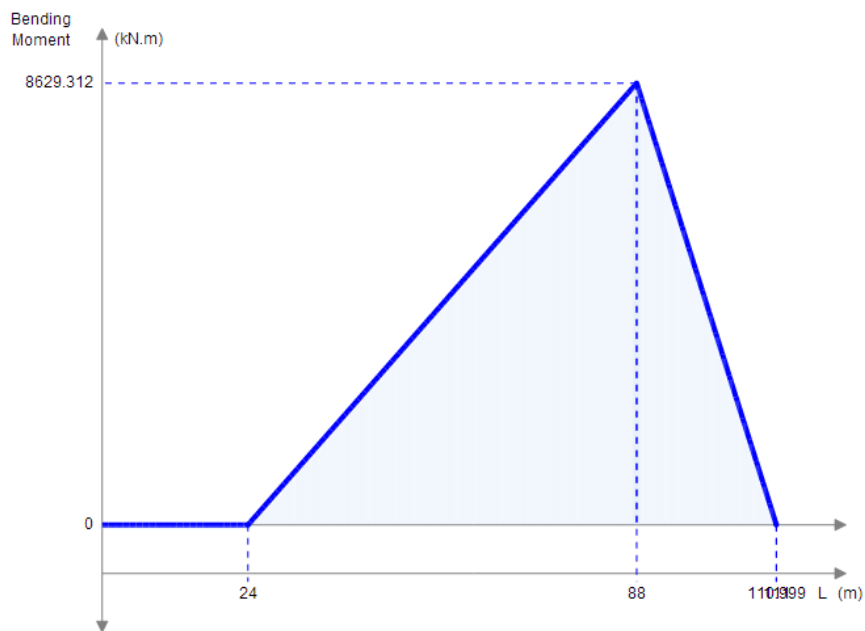
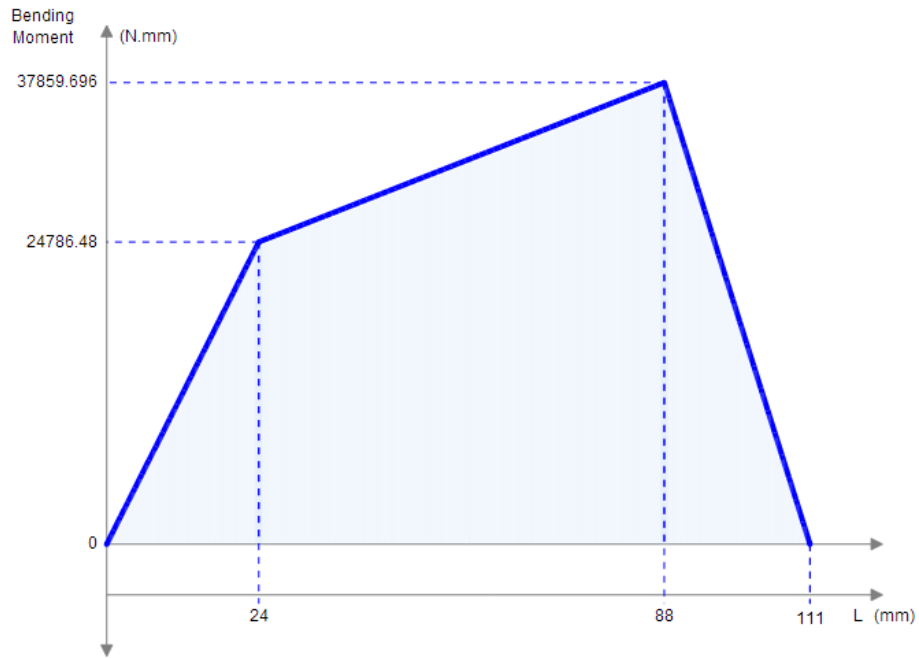

$$M_q = \sqrt{37.859696^2 + 8.529312^2} = \mathbf{38.86Nm}$$

3.2.4.11 Axial Load

The axial load is unchanged =

$$P_q = \frac{288}{\left(\frac{0.046}{2}\right)} = 12521.74N$$

3.2.4.12 Geometry factor selection

K step for AISI1440 with the same $z=0.055$ is selected from the graph below

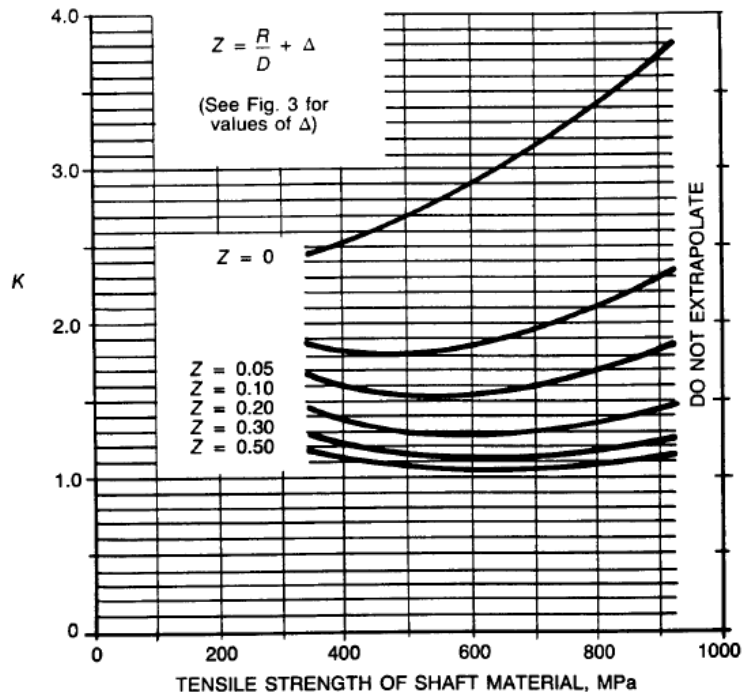

Figure 23, K step graph (Standards1403, 2011)

A value of 900 MPa is used, thus the value of K step = 2.3

We are now using involute splines, so a new K spline is selected from the graph below

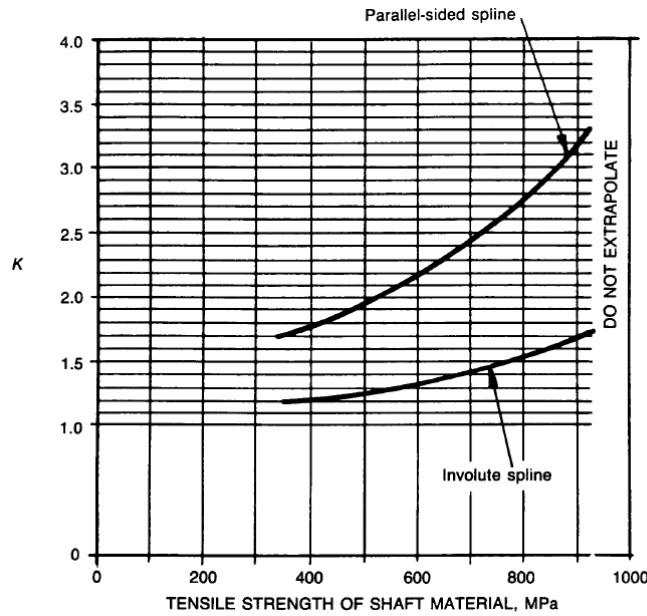

Figure 24, K spline graph (Standards1403, 2011)

K spline = 1.7

Therefore the new geometry factor $K = K_{\text{spline}} + (0.2 * K_{\text{step}}) = 2.16$

3.2.4.13 Minimum shaft diameter

$$D^3 = \frac{10^4 F_S}{F_R} \sqrt{\left[K_S K \left(M_q + \frac{P_q D}{8000} \right) \right]^2 + \frac{3}{4} T_q^2}$$

Substituting the values into the above equation,

$D = 16.433\text{mm}$ with no safety factor

With a safety factor of 1.5, $D = 18.8\text{mm}$. Therefore the new design meets our criteria. As $18.8 < 20$, the actual diameter of 20mm is greater than the minimum diameter so the shaft is suitable.

3.3 DRIVE SHAFT BEARING SELECTION

3.3.1 Current drive shaft Bearings

The drive shaft bearings used in the upright are FAG W215 6204RSR thrust bearings and FAG G137-1428HB ball bearings.

1) Thrust bearing. Thrust bearings are designed to take axial loads and cannot manage radial loads well at all so is accompanied by a ball bearing to handle radial loads.

(BocaBearings, n.d.) The thrust bearing are positioned on the hub end of the shaft to accommodate the axial loads.

Basic load ratings are **29kN** static load and **15.1kN** dynamic rating at 7500 rpm. (SKF, 2013).

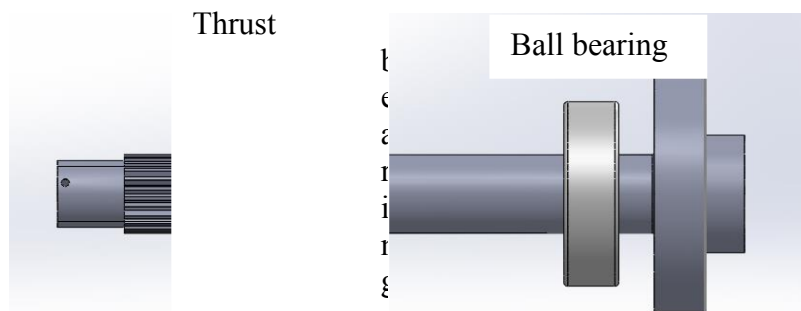

Figure 25, bearing position on drive shaft, 34mm apart

2) Radial Ball bearing is positioned on the spur gear end of the drive shaft such that it can handle the radial loads generated through the spur gear.

3.3.2 Loads on bearings

The **radial** load is calculated during the verification of the drive shaft. The largest load acting on the inner bearing as the reaction force $R_{BX} = 1850.34N \ll 13.2 \text{ kN}$ (SKF, 2013)

The **axial** load on the bearings must be calculated with the new shaft. The tire contact force is calculated using the cornering load found before ($156.85kg$) and the coefficient of friction between tire rubber and asphalt of 0.72 (Engineering tool box, n.d.). The summation of these two values gives the tire contact force of **1107.863N**

This creates a moment of 288Nm acting on the side of the bearing and the thread of the bolt. The distance between these two points is 72mm for the new shaft. Therefore the force opposing this motion is

$$P_q = \frac{288}{\left(\frac{0.072}{2}\right)} = 800N \ll 15.1kN \text{ dynamic rating}$$

Therefore the bearing selection is adequate for the use in the vehicle. Both bearings are sealed bearings with internal lubrication, so they do not need to be maintained. If a bearing fails, it is easily replaced.

4 HUB DESIGN

4.1 ORIGINAL HUB

The original hub was wire cut from mild steel. The hub has a few critical dimensions which are required to be maintained in the build as they correspond to components which must remain unchanged such as the brake system and wheels. It has 4 parallel key splines which were deformed during the test day at the track that are not shown in the dimensions below.

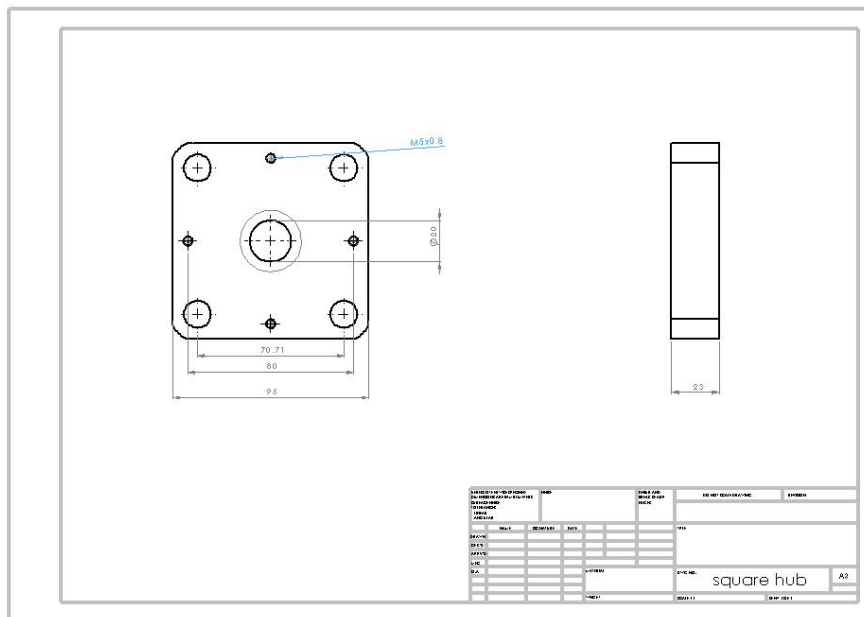

Figure 26, Critical dimensions of hub

4.2 DESIGN PARAMETERS FOR HUB

The new hub is to be made from AISI 4140 steel as decided while designing the drive shaft as this material has adequate properties for the use of a 12x20x17 DIN5482 spline. See drive shaft design for full details.

The width of the hub decides the effective length of the spline contact area. The original length is 23mm. In order to maximize the effective length the width must be as large as possible though the position of the brake mounts which are part of the hub design must not change relative to the upright position. This must be maintained at 24mm in order to use the original braking system.

This allows us to extend the hub away from the vehicle only. Extending in this direction will result in the wheels being further away from the center of the vehicle affecting the steering, and a longer drive shaft. This gives additional mass in the drive shaft and the hub so must be clearly justified.

The calculations done using ISO 14 and ISO 4156 clearly show that 23mm is adequate to handle the loads when using AISI4140 grade alloy steel. Therefore there is no justifiable reason to change the original width of the shaft.

The location of the brake mounts and wheel stud holes in the hub must remain as they were such that the original brake disk and rim will mount easily onto the new design.

4.2.1 Weight reduction of hub

In order to reduce the mass, and therefore moment of inertia of the hub, it undergoes a weight reduction from the square hub seen above. This is analyzed through finite element analysis to check maximum stresses in the system.

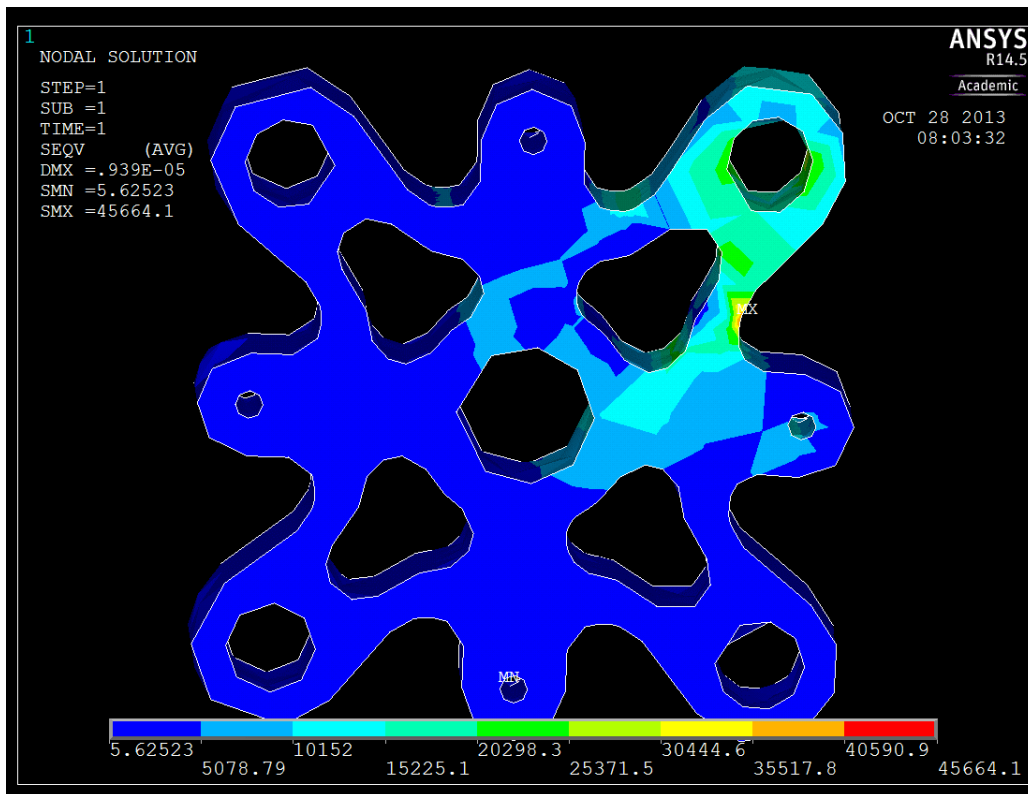

Figure 27, Von Mises analysis of hub

Loads are applied to one quarter of the hub and symmetry assumed in the rest of the hub. Due to the complex shapes created when the hub was drawn in AutoCAD, the meshing sizing is smart sizing 8, which is very coarse, though allows us to see sufficiently the loads in the shaft, and where they are focused.

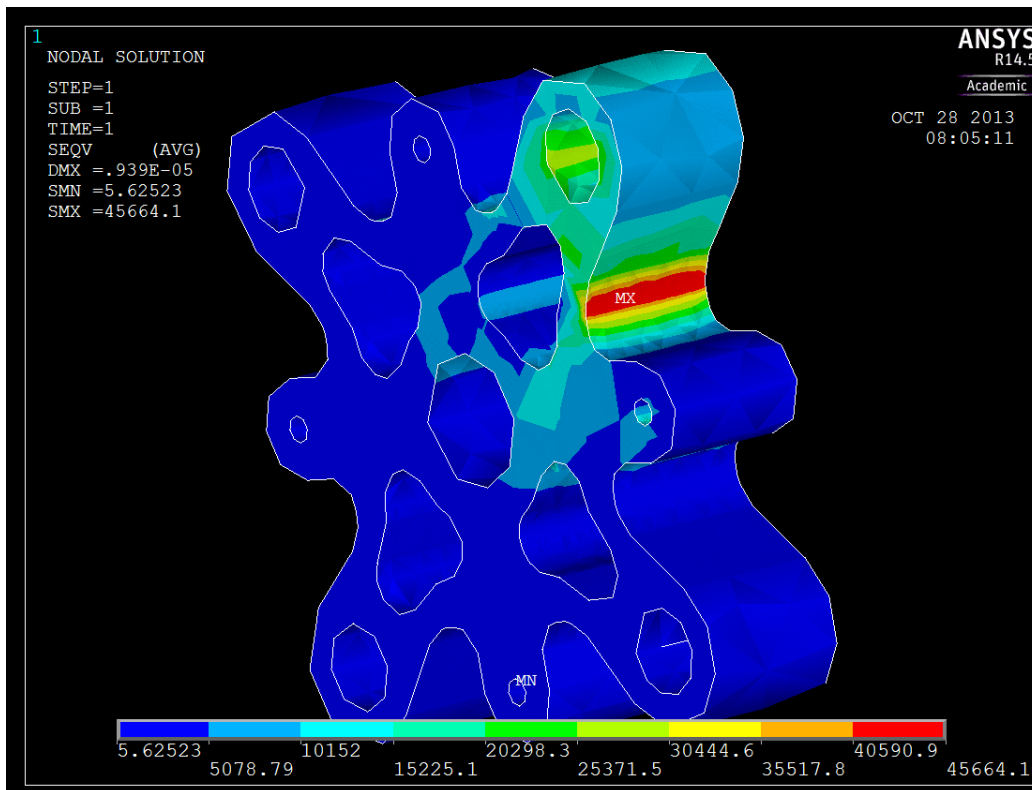

Figure 28, Von mises stresses in hub, side view

The analysis shows a maximum tensile stress of 45.664MPa which is during a loading case of maximum torque of 268.52Nm being applied through the brake mounts and the strut mounts. This gives a safety factor of 21. The dimensions however will not be reduced any more as the components undergo shock loading which is not accounted for in this analysis. Also, there are axial and radial loads as well which are not modelled here due to complications with ansys using too much hard disk space on the university computer to allow the analysis. This is likely due to transferring the object from AutoCAD.

4.2.2 Final design and manufacture method

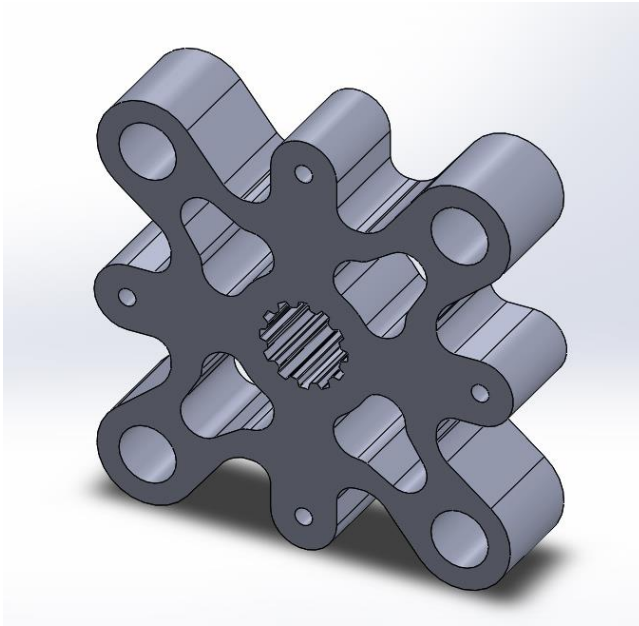

Figure 29, The new designed hub with 12x20x17 splines

In order to cut the weight reduction holes into the hub, a .dwg image is created in solidworks and imputed directly into the wire cutting compute in the UWA Physics department allowing each hub to be cut from billet AISI 4140 grade alloy steel.

4.3 SPUR GEARS

The drivetrain consists of a spur and pinion gear set. The gears are made from mild steel.

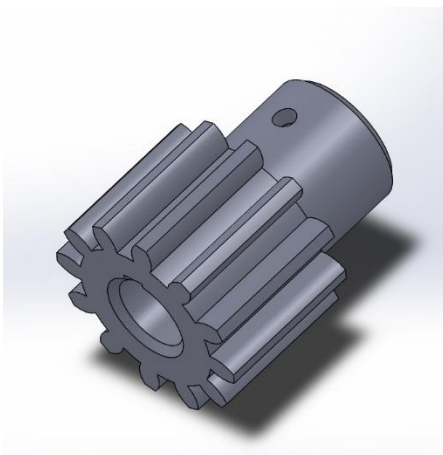

Figure 30, Pinion gear

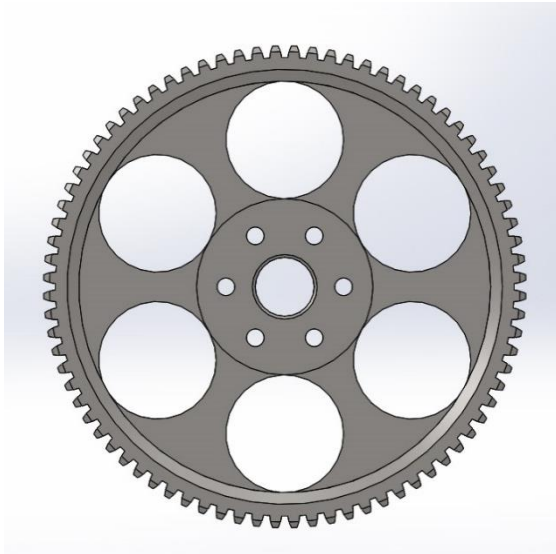

Figure 32, spur gear

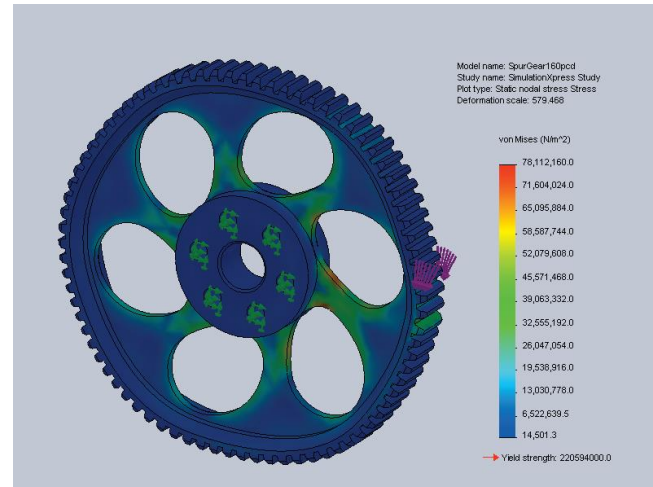

Figure 31, Von Mises analysis of gear (REV team 2012/13)

The spur gear is mounted to the drive shaft by six M5 standard bolts. The highest von Mises stress can be seen in the narrow “arms”. The loading case here is 20Nm from the motor, which produces a maximum stress of 78MN/m² which gives us a factor of safety of 2.8. The weight of the gears are 1.12kg.

This design showed no damage after the initial testing of the vehicle, and with these analysis results are acceptable to be used for the vehicle.

4.3.1 Analysis of spur gear, and pinion teeth

The basic bending stress is calculated using the Lewis formula (Beardmore, 2012)

$$\sigma = \frac{F_t}{b_a m Y}$$

Where,

F t = Tangential force on tooth

σ = Tooth Bending stress (MPa)

b_a = Face width (mm)

Y = Lewis Form Factor

m = Module (mm)

The face width for the spur gear and the pinion gear is equal = 16mm

Module of the spur gear = module of pinion gear = 2

Tangential force on spur gear = tangential force on pinion gear = 1646.075 N

Lewis form factor for pinion = 0.415 (Beardmore, 2012)

Lewis factor for spur gear = 0.615 (Beardmore, 2012)

4.3.1.1 Pinion gear bending stress

$$\sigma = \frac{1645.075}{16 * 2 * 0.415} = 123.876MPa$$

4.3.1.2 Spur gear bending stress

$$\sigma = \frac{1645.075}{16 * 2 * 0.615} = 83.59MPa$$

For AISI4140 alloy steel, the bending stress << Yield stress (965MPa)

5 MOTOR DRIVE SHAFT

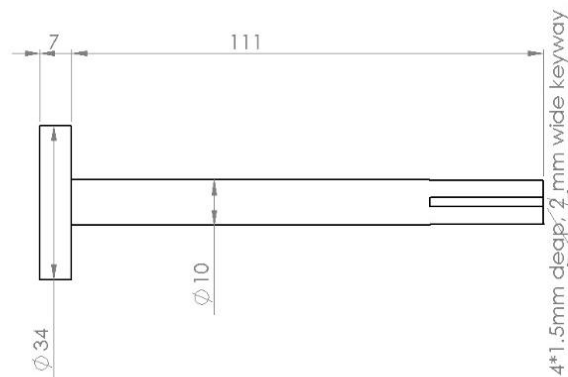

Figure 33, Motor drive shaft dimensions

The motor drive shaft is constructed out of mild steel and has 4 parallel key splines to transfer the torque from the motor to the pinion gear. The motor drive shaft is to be assessed according to the Australian standards (Standards1403, 2011).

5.1.1 Data from verification of drive shaft

Torque from motor = 20.3Nm

Rotational speed = 117.6 revolutions/sec

Moment of inertia shaft 1 (motor shaft, motor, pinion gear) = $4.528 \times 10^{-3} \text{kgm}^2$

Moment of inertia shaft 2 (drive shaft, hub, wheel, tire, spur gear) = 0.19802kgm^2

angular acceleration = 98.668rad/s^2

Material: Mild carbon steel

Tensile strength = 500MPa

Endurance limit = 225MPa

Yield strength = 350 MPa (TATA, 2013)

Shaft 1 output = $T_M - I_1 \alpha = 20.3 - (4.528 \times 10^{-3} * 98.668) = 19.853 \text{Nm}$ (Standards1403, 2011)

5.1.2 Calculation of forces on pinion gear

Tangential force $F_T = \text{force being transmitted} / \text{pitch radius}$ (Standards1403, 2011)

Pitch diameter of pinion gear = $(28 * 12) / (12 + 2) = 24 \text{mm}$

Therefore the tangential force $F_T = 19.853 / 0.012 = 1654.4 \text{N}$

5.1.2.1 Separating the forces on the pinion.

Pressure angle = $\arcsin(\text{base diameter} / \text{pitch diameter}) = \arcsin(20.6 / 24) = 30.87 \text{ degrees}$.

Pinion gear is straight cut so there is no axial load.

Radial force = $\text{Tangential force} \tan(\text{pressure angle}) = 988.96 \text{N}$

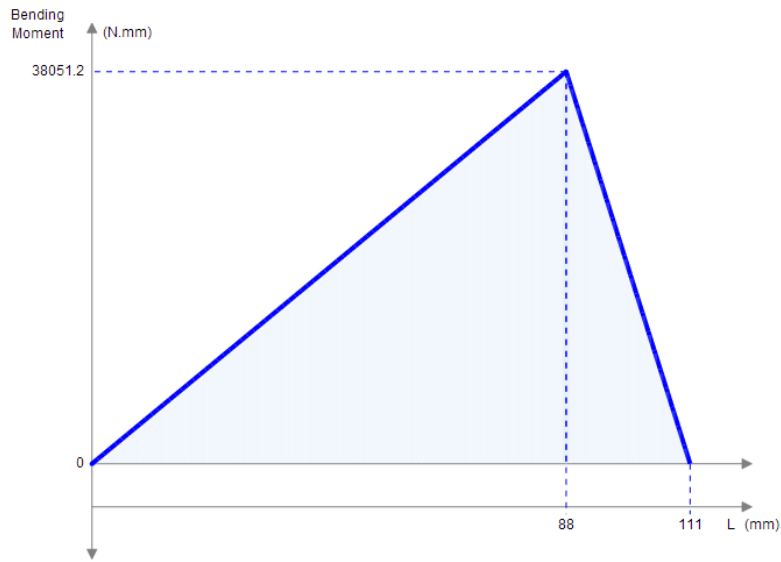

Figure 34, X-axis Bending diagram for motor shaft

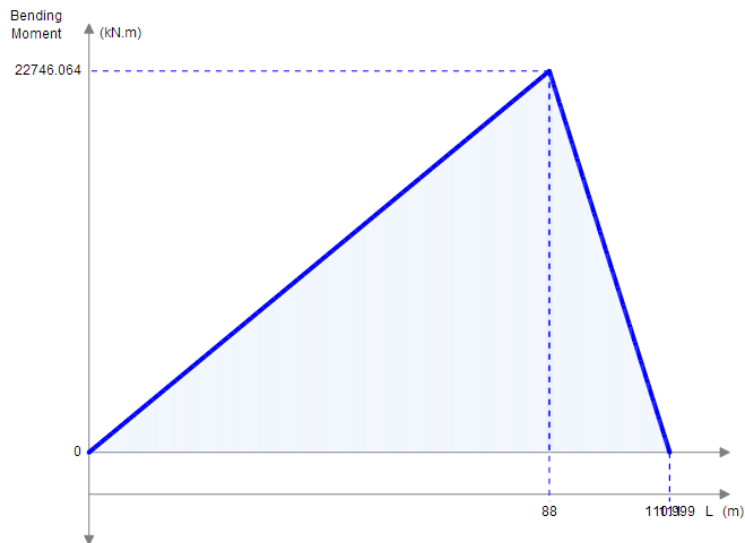

Figure 35, Y-axis motor shaft bending diagram

Bending moment in the motor shaft $M_q = \text{sqrt}(38.0512^2 + 22.746^2) = 44.33 \text{ Nm}$

Axial load in motor shaft $P_q = 0$

5.1.3 Selection of Stress factors

The factors are selected from the graphs in appendix 1

Size factor K_s for shaft diameter of 10mm = 1.0

Geometry factor K, as the shaft is both stepped and has parallel splines, the stress raisers will be considered together.

$$D_1/D = 34/10 = 3.4. \text{ Therefore, } \Delta = 0$$

$$Z = R/D + \Delta = 0.05/10 = 0.005$$

$$K_{\text{step}} = 2.7$$

$$K_{\text{spline}} = 1.95$$

$$\text{Geometry stress raising factor} = K_{\text{spline}} + (0.2 = K_{\text{step}}) = 2.49$$

Using the minimum diameter equation from table 2 of the 1403-2007 rotating steel shafts standards,

$$D^3 = \frac{10^4 F_S}{F_R} \sqrt{\left[K_S K \left(M_q + \frac{P_q D}{8000} \right) \right]^2 + \frac{3}{4} T_q^2}$$
$$D^3 = \frac{10^4}{225} \sqrt{(2.49[(44.33)]^2 + \frac{3}{4} 19.853^2)}$$

$$D, \text{ min} = 17.06 \text{ mm}$$

This is much greater than the actual diameter of 10mm. In order to solve this. The bearing is moved to be mounted on the end of the pinion gear. Thus the distance between the pinion gear and the centre of the gear is 4 mm

The process is repeated for this scenario. All the variables are the same except the bending moments. These are recalculated as below.



Figure 36, x-axis moment diagram for new bearing placement

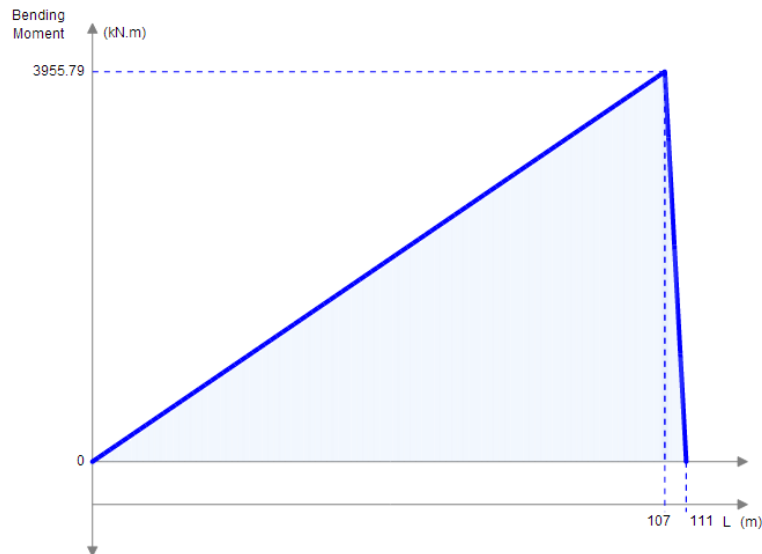

Figure 37, y-axis bending moment diagram for motor shaft with new bearing placement

$$M_q = \sqrt{(6.617629^2 + 3.95579^2)} = 7.7098 \text{ Nm}$$

Replacing this value in the equation for minimum diameter we obtain;

$$D, \text{ min} = 10.46 \text{ mm.}$$

This value is without any safety factor. This is still unacceptable. As the min diameter > actual diameter.

The diameter of the shaft cannot be increased as it passes through the center of the motor.

Therefore in order to reduce the minimum diameter of the shaft, involute splines are used instead of parallel splines. From appendix 1, the new value of K spline = 1.375

Geometry factor is then $1.375 + (0.2 * 2.7) = 1.915$.

Replacing this in the minimum diameter equation gives us the following equation

$$D^3 = \frac{10^4}{225} \sqrt{([1.915(7.7098)]^2 + \frac{3}{4} 19.853^2)}$$

$$D = 10.02mm$$

This is still marginally greater than the actual shaft.

Therefore the weakest point in the system is the motor shaft. The design of the system does not allow the shaft to be any larger in diameter. In order to fix this, the design layout will have to be changed in order to allow the drive shaft to protrude from the opposite end of the motor.

5.1.4 Alternative system layouts

As suggested by Ian Hooper we have four possible layouts,

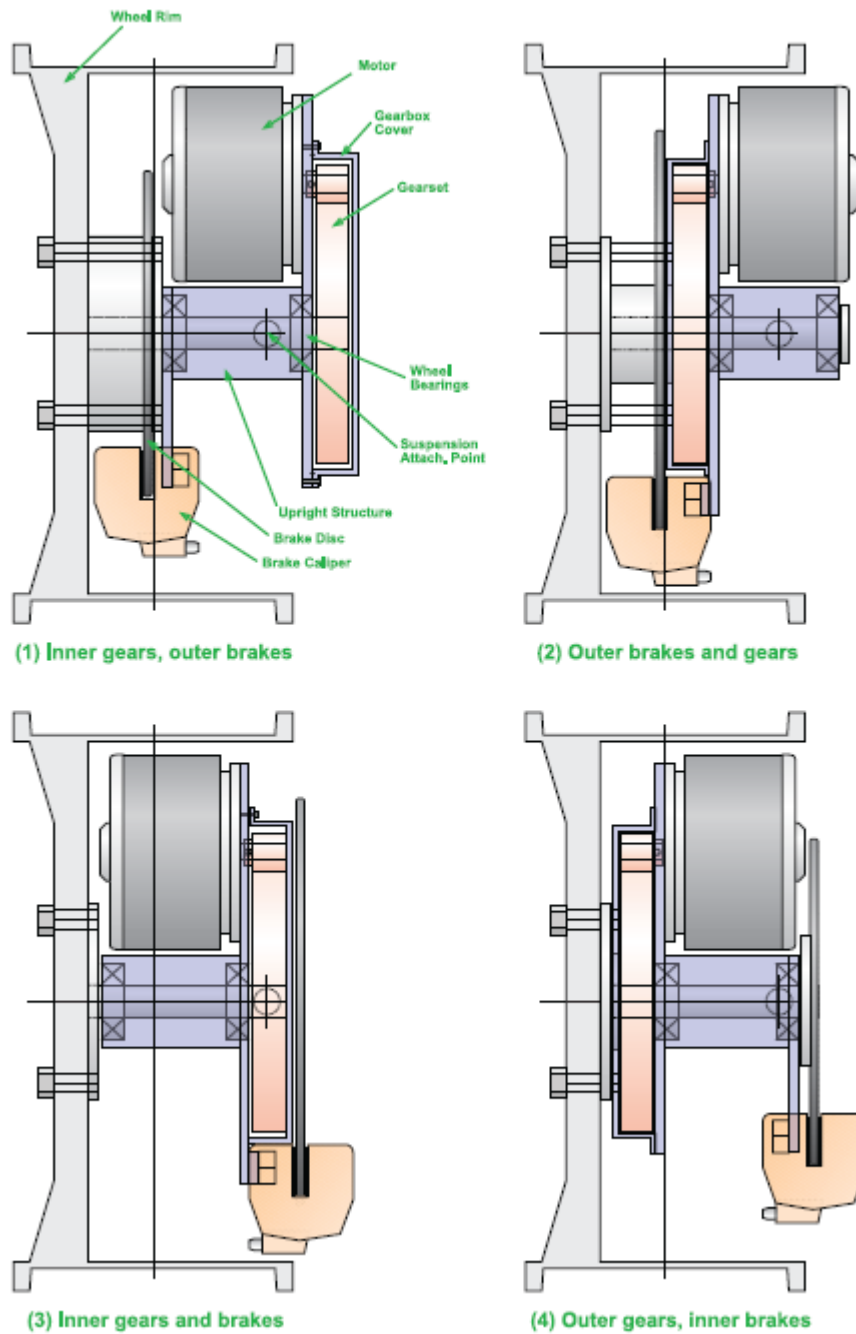

Figure 38, Suggested layouts of system by Ian Hooper

The system that is implemented is the system (1) Inner gears, outer brakes. Though none of these layouts allow the motor shaft to exit the motor on the opposite side as required. This is a flaw in the hub motor design that needs to be tackled with a complete new design. This must be done with the new car as changing the design at this point will be too costly.

6 COST

Part type	Details	Cost (AU\$)
Electric Motor	Turnigy CA-120-70 Brushless	500.00
Motor Controller	Kelly KBL73201X	700.00
Drive Shaft	20mm dia. Chromoly Splined	350.00
Motor Shaft	5mm dia. IAS1120 steel	40.00
Gearbox	Custom cut 6.6:1 Steel	300.00
HV Wiring		500.00
Terminal Lugs	Hydraulically Crimped	195.00
Motor shaft bearing	Roller bearing, 5mm inner dia.	15.00
Oil cover	Fibre glass, 1.5 mm thick.	30.00
Oil	Gear oil, 50ml per oil cover	30.00
Drive Shaft Bearings	Thrust Ball bearings, 20mm inner dia.	20.00
Wheels	Hoosier C2500 20.5x6.0-13	150.00
Tires		150.00
Axle bolt	M16 Castle nut with split pi	10.00
Wheel Studs		3.00
Rear Hubs		150.00
Front Hubs		150.00

Total cost per assembly = AU\$3143

7 CONCLUSION

All the relevant parts and components have been checked according to relevant standards and regulations. This has allowed the design of new structurally sound components and identified the weak point in the system which is the motor shaft. This flaw cannot be resolved on the current car so spare motor shafts are to be made and taken to the competition with the team. The cost of each shaft is AU\$40 so 2 spare shafts will be made. The damage that could be caused by the breaking of the shaft will be limited to the spur and

pinion gear as they are incased in a cover, and separate from other moving parts. The gears cost AU\$ 300 for each set so spares will not be made for these components. This leaves the car at a high risk of not finishing its first race. The cost of re-designing the system is much greater than the cost of breaking a gear set or two, so the car will still be run.

The breaking of the motor shaft has no safety concern as there is a guard cover to block possible debris and the steering/brakes/traction are all unaffected by a break in the motor shaft. Worst case scenario is a wheel locking up (jamming).

Overall, I believe this is a successful thesis and allows for a car that can be used next year for driver training events and sponsorship events.

8 REFERENCES

- (n.d.). Retrieved from Engineering tool box: http://www.engineeringtoolbox.com/friction-coefficients-d_778.html
- Beardmore, R. (2012, 04 06). Retrieved from Roymech: http://www.roymech.co.uk/Useful_Tables/Matter/Steel_Europe_2.html
- BocaBearings. (n.d.). *Bearings for industry*. Retrieved from Bocabearings: <http://www.bocabearings.com/bearing-types/thrust-bearings>
- fltechnical:suspension*. (2009, August 26). Retrieved from fltechnical: <http://www.fltechnical.net/articles/39>
- MatWeb. (2013). *MatWeb*. Retrieved from Material Property Data: <http://www.matweb.com/search/datasheet.aspx?matguid=95d75368d1634a2eaf2ab8723510b218&ckck=1>
- Normen, D. (1973, march). Involute spline profiles. *DIN5482*.
- SAE, i. (2013). FSAE rules.
- SKF. (2013). Retrieved from SKF: <http://www.skf.com/au/products/bearings-units-housings/ball-bearings/thrust-ball-bearings/single-direction/index.html>

Standards1403, A. (2011, 05 02). AS1403-2004. *Rotating steel shafts*. Standards Australia.

TATA, s. (2013). Retrieved from TATA:

http://www.tatasteelnz.com/downloads/HighTens_AISI4140.pdf

Wright, D. (2001). *Mechanical Design*.

9 APPENDICES

9.1 STRESS RAISING FACTOR GRAPHS

9.1.1 Size factor

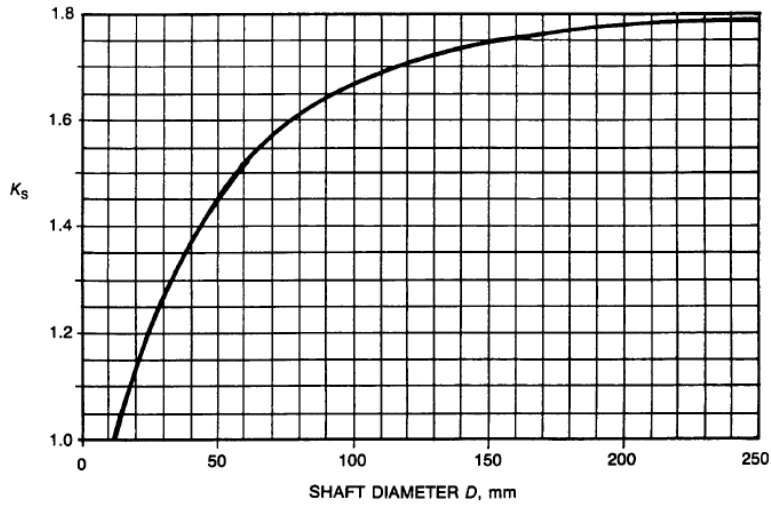

9.1.2 Correction factor

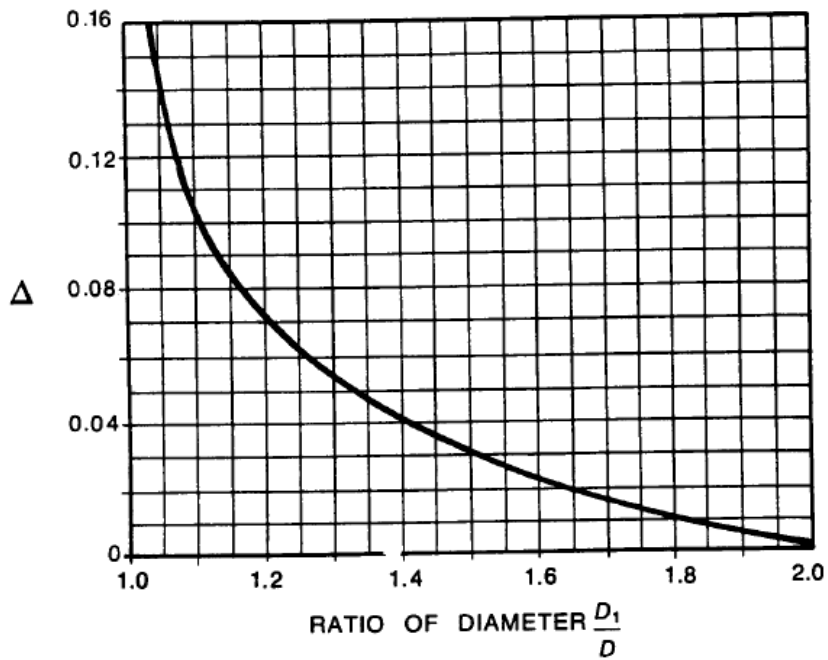
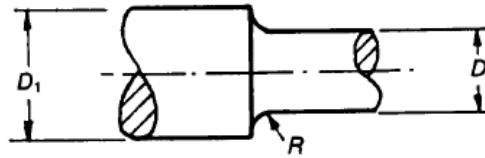

9.1.3 Stress raising factor K for stepped shaft

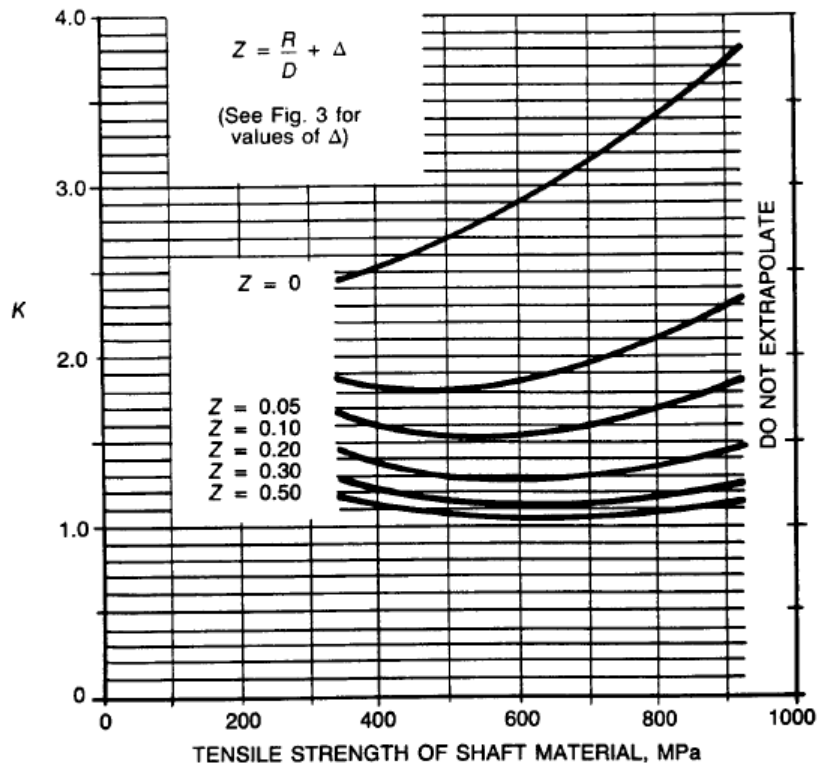

9.1.4 Stress raising factor K for splined shaft

