



THE UNIVERSITY OF  
WESTERN AUSTRALIA

SCHOOL OF ELECTRICAL, ELECTRONIC AND COMPUTER ENGINEERING

# The REV Project

---

Electric Vehicle Design Concepts and Project  
Management

Rohan Mathew



*Submitted in partial fulfilment of the  
requirements of the award Bachelor's  
degree of Electrical/Electronic Engineering  
and Computer Science*



The REV Project

Rohan Mathew

15 Gladman Way  
KARRINYUP  
WA, 6018

The Dean

Faculty of Engineering Computing and Mathematics  
The University of Western Australia  
35 Stirling Highway  
CRAWLEY, WA 6009

Dear Madam,

I submit to you this dissertation entitled "The REV Project – Electric Vehicle Design Concepts and Project Management" in partial fulfilment of the requirement of the award of Bachelor of Electrical Engineering and Computer Science.

Yours faithfully,

Rohan Mathew

# Table of Contents

<b>TABLE OF CONTENTS</b> .....	<b>4</b>
<b>LIST OF FIGURES</b> .....	<b>6</b>
<b>LIST OF TABLES</b> .....	<b>7</b>
<b>LIST OF SYMBOLS</b> .....	<b>8</b>
<b>ABSTRACT</b> .....	<b>9</b>
<b>1 INTRODUCTION</b> .....	<b>10</b>
1.1 AIMS AND OBJECTIVES .....	15
<b>2 LITERATURE REVIEW</b> .....	<b>16</b>
2.1 DRIVE TRAIN TECHNOLOGY .....	18
2.2 POWER, BATTERY AND EFFICIENCY .....	19
2.3 EVALUATION MODELLING AND SIMULATION .....	20
2.4 CONTROL SYSTEMS .....	21
2.5 SYSTEM DESIGN .....	22
2.6 RANGE OF PRESENT WORK .....	24
<b>3 PROJECT MANAGEMENT</b> .....	<b>25</b>
3.1 MATERIALS ACQUISITION .....	25
3.2 SPONSORSHIP .....	25
3.3 GRANTS AND OTHER FUNDING .....	26
3.4 DEVELOPMENT METHODOLOGY .....	26
3.5 TEAM AND DEVELOPMENT PROCESS .....	29
3.6 WEBSITE .....	32
<b>4 REQUIREMENTS ANALYSIS</b> .....	<b>33</b>
4.1 AIMS .....	33
4.2 FUNCTIONAL REQUIREMENTS .....	34
4.3 NON-FUNCTIONAL REQUIREMENTS .....	39
<b>5 ECO: COMMUTER DESIGN</b> .....	<b>40</b>
5.2 TRACTION SYSTEMS .....	40
5.3 PREPARATION AND INSTALLATION .....	49
5.4 TOPOLOGY .....	51
<b>6 AUXILIARY SYSTEMS</b> .....	<b>52</b>
6.1 INSTRUMENTATION AND CONTROL .....	52
6.2 ACCESSORIES .....	53
<b>7 METHODS</b> .....	<b>59</b>
7.1 MODEL .....	59
7.2 REV Eco .....	66

<b>8</b>	<b>RESULTS AND ANALYSIS</b> .....	<b>69</b>
8.1	WORKSHOP.....	69
8.2	SOLAR PANEL SYSTEM.....	69
8.3	PROJECT STRUCTURE.....	70
8.4	WEBSITE.....	70
8.5	VEHICLE.....	71
<b>9</b>	<b>DISCUSSION</b> .....	<b>75</b>
9.1	DRIVE.....	75
9.2	MODEL AND LIMITATIONS.....	75
9.3	SUGGESTIONS OF VEHICLE IMPROVEMENT.....	76
9.4	FUTURE WORK.....	77
<b>10</b>	<b>CONCLUSIONS</b> .....	<b>78</b>
<b>11</b>	<b>ACKNOWLEDGEMENTS</b> .....	<b>79</b>
<b>12</b>	<b>REFERENCES</b> .....	<b>80</b>

# List of Figures

Figure 1: Example of Suburban Sprawl (Courtesy: <i>The New Republic</i> ).....	10
Figure 2: 2006 CO <sub>2</sub> Emissions by Sector and Fuel Type (USEPA 2008).....	10
Figure 3: Oil Prices 1994 - March 2008 (Source: Reuters).....	11
Figure 4: Costa Pinto Bio-alcohol production plant. (Courtesy: Wikimedia Commons).....	12
Figure 5: Grid to Motor Efficiencies for EV vs. HV - Adapted from: (Tesla 2007) .....	13
Figure 6: Crushed EV1 (Source: Treehugger) .....	14
Figure 7: Advertisement for the Detroit Electric 1912 (Source: Public Domain) .....	16
Figure 8: Primary Principles of EVs remain the same (Young 1994) .....	17
Figure 9: Tesla Roadster Cross Section (Courtesy: Treehugger) .....	18
Figure 10: Motor / Hub Assembly (Monkhouse et al. 1993).....	19
Figure 11: In-Car Computer in Prius Hybrid Electric (Courtesy: Edmunds Insideline) .....	22
Figure 12: Buckeye Bullet at Bonneville (Courtesy: Bath Township Fire Department) .....	23
Figure 13: Power Electronics Function Blocks of an EV (Vezzini & Reichert 1996) .....	23
Figure 14: Spiral Model of Design (Courtesy: Elman).....	26
Figure 15: Formal meetings for task allocation and reporting. ....	27
Figure 16: Informal meetings for technical consultation and issue resolution.....	27
Figure 17: Student Workload Distribution.....	29
Figure 18: Development Process Flow .....	31
Figure 19: Screenshot of TheREVProject.com .....	32
Figure 20: Interior of Hyundai Getz (Courtesy: Hyundai) .....	35
Figure 21: Servicing Range of a 80-120km Commuter Electric Vehicle .....	37
Figure 22: Hyundai Getz 2008 Size and Dimensions .....	41
Figure 23: a) Permanent Magnet and b) DC Motor with Wound Stator (Hooper 2008).....	42
Figure 24: Brushless DC (Hooper 2008) .....	42
Figure 25: Motor Configuration in Engine Bay.....	42
Figure 26: Topology of a Modern Motor Speed Controller .....	43
Figure 27: PWM of Motor Voltage.....	43
Figure 28: Controller Configuration in Engine Bay .....	43
Figure 29: Specific Energy of Hydrocarbon Based Fuels - Adapted from Thomas (2003).....	44
Figure 30: Battery Configuration in Boot .....	45
Figure 31: TS90 Battery Management System Connections.....	47
Figure 32: Cross section of Primary Distribution Cable.....	48
Figure 33: REV Eco Emergency Disconnect .....	49
Figure 34: Cleared Engine Bay with DC Motor installed. ....	49
Figure 35: Charging cable connected to Recharging plug in fuel door. ....	50
Figure 36: Installed Eyebot configuration on dash .....	50
Figure 37: Overall System Topology .....	51
Figure 38: Eyebot Mk 6 Controller .....	52
Figure 39: Topology of the Accessories Rail .....	53
Figure 40: Heating Element in custom housing .....	55
Figure 41: Heater Core Pin-out .....	56
Figure 42: LFP90AHA Modelled as 94Ahr Battery with 1.025 Peukerts .....	67
Figure 43: TheREVProject.com Usage Statistics as of 1 <sup>st</sup> Nov 2008.....	70
Figure 44: Total Opposing Forces acting on Eco .....	72
Figure 45: Theoretical vs. Probable Maximum Range .....	72

# List of Tables

Table 1: Total Kilometres Travelled by State/Territory of Registration (Courtesy: ABS).....	36
Table 2: Gear Analysis of REV Eco.....	73
Table 3: Cost analysis for a 45km commute by avg. speed.....	74
Table 4: Breakdown of Drag contribution by Chassis Area (Brant 1993).....	76

# List of Symbols

ABS	– Antilock Braking System
ADC	– Advanced DC
BMS	– Battery Management System
DOD	– Depth of Discharge
EE	– Electrical Engineering
EV	– Electric Vehicle
FET	– Field Effect Transistor
HTML	– Hypertext Markup Language
ICE	– Internal Combustion Engine
LED	– Light Emitting Diode
LFP	– <i>see LiFePO</i>
LIFEP0	– Lithium Iron Phosphate
MCU	– Master Control Unit
MOSFET	– Metal Oxide Semiconductor Field Effect Transistor
PTC	– Positive Temperature Coefficient
PWM	– Pulse Width Modulation
REV	– Renewable Energy Vehicle, <i>also: revolutions</i>
RPM	– Revolutions Per Minute
SOC	– State of Charge



# Abstract

This paper presents a detailed explanation of the basic concepts of electric vehicles and their advantages over common internal combustion driven vehicles. The social, environmental and economic need for change from an oil cantered lifestyle has been introduced, as well as an overview of alternative fuels and previous work relating to electric vehicle design and development.

This study found that the present performance characteristics of electric vehicles were particularly suited to commuting and short range racing. This research was furthered by formalising the requirements of a vehicle oriented towards these duties.

The design and implementation of a five seater, super-miniature class commuter vehicle with a servicing range of 80-100 km was discussed. A theoretical model to predict the performance of an electric vehicle was developed, and showed that the vehicle was viable for commuter use.

# 1 Introduction



Figure 1: Example of Suburban Sprawl (Courtesy: *The New Republic*)

A dramatic growth in population, coupled with a shortage of low cost housing, has contributed to significant development in Perth and its outer suburbs. This phenomenon is referred to as urban sprawl (Figure 1), and is known for contributing to a host of environmental and health issues (Hirschorn 2005). Residents of these sprawling neighbourhoods emit high levels of pollution per person and suffer high traffic fatality levels, due to the inability of walking and cycling to act as viable commuting options, as well as the inefficiency of public transportation across these sprawls (Duany 2001). These communities are highly dependent on automobiles for transportation, a major contributing factor to traffic congestion and air pollution known as urban smog (Bruegmann 2005).

Additionally, with increasing concerns about global warming and climate change, public focus has been directed toward reducing air pollution, specifically CO<sub>2</sub> based emissions that, in the US, contribute to 84.8% of all emissions (USEPA 2008). The single largest source of these emissions is the combustion of fossil fuels of which the transportation sector is the second largest contributor (Figure 2).

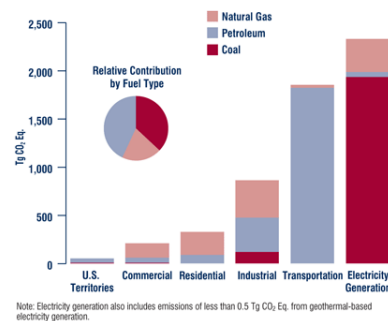

Figure 2: 2006 CO<sub>2</sub> Emissions by Sector and Fuel Type (USEPA 2008)

Almost all of the energy consumed in the transportation sector is petroleum based, including gasoline, diesel and jet fuel. Automobiles and light duty trucks account for almost two thirds of emissions from this sector and these figures have grown steadily since 1990 (USEPA 2008).

Emissions levels from transport vehicles depend on the duration and frequency of vehicle use. This in turn is influenced by larger economic trends and consumer behaviour (USEPA 2008). In the long term it is the fuel efficiency of these vehicles (and the type of fuel used) which has the largest influence on emissions.

Proficient use of petroleum, over the past 60 years, has now turned into a system of dependence that has been recognised as contributing to a host of geopolitical, environmental and economic issues (Sandalow 2007).

Most readily apparent to the end consumer, particularly over the past five years, is the economic impact of the incline of fuel prices (see Figure 3).

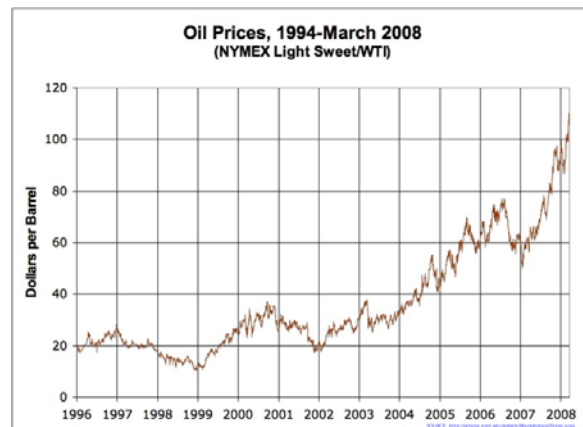

Figure 3: Oil Prices 1994 - March 2008 (Source: Reuters)

The price elasticity of demand for oil is very low, primarily due to the lack of readily available substitutes (Cooper 2003). As a result, increased prices have smothered economic growth, with research showing that oil prices may have a bigger impact on inflation than government fiscal policy (Hooker 2002).

But what of these substitutes? The range of possible alternative fuels sources for transportation is vast, varying from oil based products supplemented with natural bio-fuels, to hydrogen and electricity (see Appendix B.1). Additionally, hybrid technologies exist which can utilise two or more fuels for vehicle propulsion. These fuels have varying degrees of availability and differing levels of environmental impact.

Oil based variants such as Diesel, CNG, LNG and LPG burn more efficiently and produce reduced amounts of direct emissions compared to petrol, but still contribute significantly to air pollution. Rapidly improving technology has further reduced the level of emissions produced by modern vehicles. However, designing and testing emission reducing technologies and then re-tooling production facilities can take several years (Sandalow 2007). In the US, new car sales account for 6.5% of the total vehicle fleet every year, which equates to around 15 years for the turnover of the entire fleet (Plunkket 2008).

This in turn means that any developments in emission reducing technology can take over two decades to propagate to the end user.

Oil based fuels are already widely produced and distributed and require very minor changes in present infrastructure and vehicle technology to implement. Still, the uptake of these products is slow and the comparative environmental and economic benefits are reduced – these fuels still produce unsustainable emission levels in the long term and do not serve to mitigate domestic dependence on oil.

The desire for independence from oil based alternatives has led to a growth in new sectors producing bio-alcohols and bio-fuels from organic (usually plant-based) sources. These sources include soy bean, rapeseed, vegetable and corn oils and can also include crops such as sugar cane and by-products such as agricultural waste and animal fats. Bio-fuels drastically reduce direct CO<sub>2</sub> emissions (with varying effects on NO<sub>2</sub>) and have been trailed with considerable success particularly in Brazil, the second largest producer of ethanol in the world (Inslee 2007).



Figure 4: Costa Pinto Bio-alcohol production plant. (Courtesy: Wikimedia Commons)

Brazil is considered to have the world's first sustainable bio-fuel economy, on the back of government enforced regulatory change to phase out fossil fuels in favour of ethanol produced from sugar cane (Inslee 2007).

However, Brazil's success is not without its share of environmental problems including rainforest destruction and smog from the clearing of sugar cane fields and from ethanol production facilities (Figure 4). In recent years, concerns about the large amount of arable land required for bio-fuel crops, as well as the energy and pollution balance from the bio-fuel production cycle, have caused considerable debate about the use of bio-fuels as a replacement for fossil fuels in vehicles.

In the past, hydrogen has been suggested as a viable alternative to an oil based economy. Unlike the other fuels discussed, hydrogen acts as an energy carrier, not a primary energy source. There is no natural reserve of un-combined hydrogen and so the product must be synthesised through steam methane reformation or electrolysis of water. When this synthesis is powered from renewable resources, hydrogen is considered to be an environmentally clean source of energy with no tailpipe emissions.

However, there are a number of issues with the technology that make it unlikely that end users will ever see a hydrogen economy.

Of primary concern is the complexity and expense of hydrogen technology and the difficulty of safe distribution (Gross, Sutherland & Mooiweer 2007). Additionally, the technology is considered the least efficient and most expensive replacement of gasoline for the reduction of greenhouse gases (Boyd 2007). It is argued that for many applications a direct substitution and use of electricity, such as the chemical batteries in electric vehicles, would accomplish many of the goals while requiring only a fraction of the technology investment (Olah et al. 2006).

Electric vehicle technology utilises a central traction battery to energise an electric motor. Unlike hydrogen technology, electric vehicles are capable of operating at extremely high efficiencies, not requiring the state changes that cause efficiency loss (Figure 5).

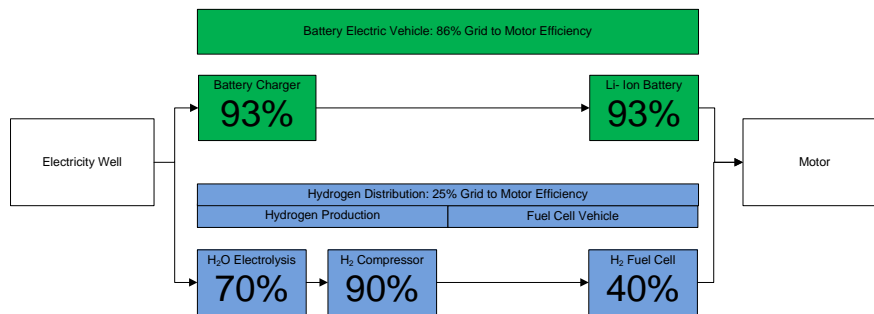

Figure 5: Grid to Motor Efficiencies for EV vs. HV - Adapted from: (Tesla 2007)

In most cases, vehicles can be recharged from a standard plug-point and some are also capable of improving operating efficiencies by utilising regenerative braking. The power is then conveyed to the vehicle through the existing power grid infrastructure. The technology decouples the energy generation component from automobiles, effectively converting them into appliances.

How we power these appliances is a problem that can be solved with sustainable power generation. Consumers have the choice of utilising green sources (such as solar power, which is the focus of this work) or, at the very least, benefiting from economies of scale and the efficiency gains of producing power in a production plant, as opposed to a number of decentralised and mobile combustion engines. As the power grid transitions to renewable sources, the vehicles too, would seamlessly transition.

Further, switching to electric drive technology reduces consumer consumption and dependence on oil (Murray & Ostrowski 1981). Studies have found that the energy distribution capability of existing infrastructure is sufficient to manage the largely off-peak load so a transition to electricity can take place quickly with little need for infrastructure change (Salihi 1973).

Despite their high efficiencies, electric vehicles are restricted by their operating range and recharge times, both of which are limited by battery performance. As battery technology improves, the feasibility of the vehicle as a robust alternative improves in turn. Coupled with cheap operating costs and low maintenance, electric vehicle technology is fast becoming a viable alternative means of transportation.

Battery limitations aside, plug-in electric vehicles have been utilised in the past with much success. In Los Angeles, concerns over excessive urban smog mandated the development and commercialisation of alternative fuel vehicles, resulting in the limited release of the General Motors EV1. The documentary *"Who Killed The Electric Car"* (Paine 2006) describes the ensuing events, including the industry pressured reversal of the mandate and the subsequent controversy when the EV1s were terminated from their lease and destroyed (Figure 6). The EV1 was so successful in its operating life that most owners turned activist and protested the destruction of the vehicles and even offered GM \$1.9 million for the remaining 78 vehicles (Paine 2006).



Figure 6: Crushed EV1 (Source: Treehugger)

The documentary explored the opposition of the oil and car manufacturing industries to electric vehicle technology (Paine 2006). It is evident that a number of political and economic factors have now come into play and that any reform in the transportation sector will require strong regulatory support. Regardless, if examples such as Brazil's booming ethanol industry are any indication, this change will be rapid and largely beneficial.

With dependence on oil affecting our environmental, social and economic sustainability and transportation forming a core component of this dependence, it is apparent that research into alternative transportation and associated technologies can have a far reaching and beneficial impact on our lifestyle.

With this in mind The REV Project aims to develop an environmentally sustainable alternative means of transportation - a vehicle and fuelling system to meet the transportation requirements of the modern commuter. This project will demonstrate how to design, construct, operate and maintain an electric vehicle for high system efficiencies utilising commercially available battery technology. It will draw on a variety of previous research and resources intended for the UWA hydrogen fuel cell vehicle.

This project is not limited to simply presenting a viable solution, but will additionally develop an incentive for change.

As discussed earlier, limitations of present battery technology mean that the range capabilities of present day electrics are relatively inflexible. Electric cars can, however, compete with and better their petrol and hybrid counterparts, with superior acceleration characteristics, operating costs and overall efficiency. To demonstrate this, a second electric car will be developed to benchmark these performance characteristics on the race track.

It is hoped that through competition the project can raise public awareness, develop technical understanding and foster a production engineering environment for participating students.

Ultimately, the source of power for electric vehicles needs to be sustainable - otherwise the solution simply transfers the problem to another locale. The REV project aims to develop a fuelling system which operates independently, reliably and sustainably in conjunction with the vehicle, to produce a transportation platform that is entirely sustainable.

## 1.1 Aims and Objectives

The REV Project aims to promote sustainable living through the development of environmentally friendly transportation alternatives for the general public.

Additionally, the project aims to demonstrate the technology and increase public awareness of its capabilities.

The project has two primary objectives:

1. To develop two concept electric vehicles and a corresponding fuelling system, and to demonstrate the technical and financial viability of electric propulsion technology for commercial use. This development will occur with a focus on minimizing the environmental and economic footprint of production and long term operation.

The project will formalize an electro-mechanical system to provide the appropriate propelling torque, storage of charge, management of speed, moderation of power consumption and provision of electrical systems and driver amenities.

We will prototype:

- a. An economy car to present commuters with a cost effective, emission free means for intra-city transport.
  - b. A race-car to demonstrate the performance of the technology in competitions both locally and internationally.
  - c. A safe, reliable and renewable charging system that will provide the vehicle with adequate power and divert the surplus supply to the power grid.
2. To increase the awareness of the state of the technology and the principles behind the REV system.
    - a. To present a commercially viable and sustainable solution for the transportation issues within Perth and its surrounding suburbs.
    - b. The project work, in conjunction with the IDEAL House Project, will educate members of the general public (as well as primary, high-school and undergraduate students) on concepts of sustainable transportation and living.

The focus of this thesis will be on The REV Project's Top Level System Design including discussion of electric vehicle conversion concepts and will include elements of project management.

# 2 Literature Review

---

Regardless of the final source of power for the Renewable Energy Vehicle, there will be a core dependence on an electro-mechanical system to provide the appropriate propelling torque, store charge, manage power consumption and provide electrical systems and amenities such as those found in typical cars to date. The focus of REV in 2008 is in electric vehicle design and construction.

This chapter conducts an examination into past and present scientific literature pertaining to the development, background and design of electric vehicles and their subsystems.

Electric vehicles are not a new phenomenon – the electric car was among the earliest automobiles - first developed in the early 19<sup>th</sup> century by Scottish businessman Robert Anderson. By the 20<sup>th</sup> century, vehicles such as the Detroit Electric (Figure 7) outsold gasoline powered alternatives, marketed as city cars and promoted for their clean and quiet operation (Young 1994). With the introduction of the highly successful Ford Model T in 1908 and later the invention of the electric starter in 1913, gasoline vehicles quickly became more practical than their electric counterparts (Wakefield 1978). Combined with advances in combustion technology, this led to the downfall of the electric vehicle automobile industry by the late 1930s (Schiffer 2003).



Figure 7: Advertisement for the Detroit Electric 1912 (Source: Public Domain)

Modern advances in materials and designs have just promoted the *rebirth* of electric vehicles for transportation. D’Agostino (1993) wrote in his article on the historical motives driving the existence of the commercial electric car: “never before have political, economic, and environmental issues all simultaneously served to strongly motivate the return to the electric vehicle until now. These three factors have provided the pressure necessary to bring about the technological advancements that will return the electric vehicle to the showroom.”



It wasn't until 1973 that theoretical predictions were made on the requirements of a commercially viable modern electric car. It was found that electrically powered vehicles were the most feasible solution for an alternate power system that was capable of complementing the "future modes of power generation for providing industrial, residential, and commercial requirements" (Salihi 1973). As before, the technology was safe, efficient and capable of reducing pollution without "disturbing the balance of resources and economy" (Salihi 1973). The early research found a comparative performance between early 70's combustion engines and electric cars and determined the impact of electric cars on electric power generation and distribution systems, assuming their widespread use by the 1990's (Salihi 1973).

It is noted that "batteries with lower energy density can provide sufficient driving range to fulfil a significant portion of our transportation needs" (Salihi 1973). Interestingly, these findings were based on the presence of the (then) yet to be developed "high energy and power density battery of 100 Wh/lb" (Salihi 1973). Today's best Lithium Ion batteries are capable of achieving these values (Joshi & Deshmukh 2006).

We found Salihi's (1973) work to be a validation of the theoretical feasibility of electric transport and a vital resource to extrapolate the present and future performance of electric vehicle technology.

The technology for the electric car has been progressively improving over the years, but the principles have remained predominantly the same (Figure 8) (Gringmuth 1996; Young 1994). Further examination into the requirements of an electric commuter vehicle will be conducted in this study (see Chapter 4: Requirements Analysis).

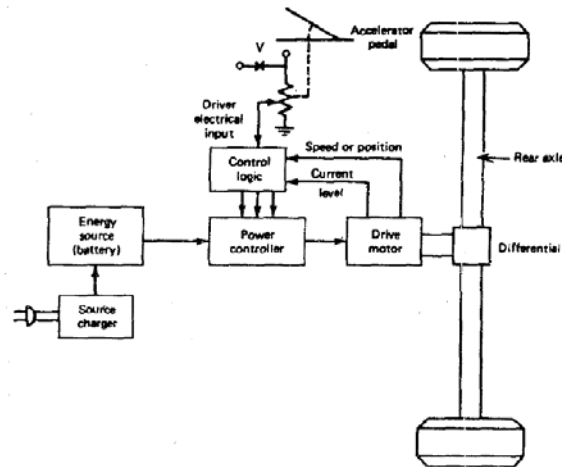

Figure 8: Primary Principles of EVs remain the same (Young 1994)

Recently, the advantages of the technology, coupled with a growing need for alternative fuel sources, has inspired renewed investment into electric vehicle research as evidenced in concepts from Toyota, Honda, Nissan and others (Yerkes 1994). As the choices between plug-in electric vehicle and hybrid technology grow and increasingly present alternatives to gasoline-engine propulsion, studies and reviews that investigate the relative merits of these technologies have been also been undertaken (Oman 2002).

## 2.1 Drive Train Technology

In the past, examination into a number of propulsion systems using AC, DC and combinational sources have taken place. The research has investigated a number of techniques including characterized AVI, PWM and similar DC chopper power processors, as well as conducting further examination into electrical interfacing techniques with a variety of motor types (Berman & Gelb 1974). The fundamentals of this research are still applicable today, but were not utilised in this work other than to select between similar technologies and their relative merits.

Motor selection and characterisation is flexible and highly dependent on the operational requirements, system budget and market availability. No substantial formal work has been done in benchmarking electric vehicle motors, however, hobbyists such as Halstead (2006) and Rick (2005) have conducted independent research in benchmarking commonly used EV motors and their performance characteristics. A model of EV performance, developed later in this work, will draw from their work and utilise behavioural parameters discovered in this process.

As discussed earlier, a number of commercially available electric cars are present in the market today, ranging from the Tesla Roadster (Figure 9) to the RECC REVA-I. These cars utilise a simple, reliable, mid-range drive train, utilizing various customizations for improved performance (top speed, acceleration and hill climbing).



Figure 9: Tesla Roadster Cross Section (Courtesy: Treehugger)

A number of commercial “white” papers have been released on these vehicles and while most of them are written from a proprietary standpoint, they do, however, illustrate areas in which the technology requires improvement (John 2006; Tesla 2007; Voelcker 2007). The papers also present a general overview as to how these improvements can be achieved. This project will keep an eye on technological changes in the industry throughout its duration.

Performance vehicles differ somewhat to typical commuter vehicles, especially in the electric genre. Trade-offs exist between instantaneous performance, range and cost. Vehicles that combine dual battery technologies to achieve high performance and usable range have been proposed, but are typically complex and expensive (Bourne & Ball 1993).

There are a number of considerations that should be accounted for in the design of a performance drive train. Monkhouse *et al.* (1993) proposed a drive system that permitted 4-wheel drive, with electronic stability control as well as high system ratings and efficiencies. The system utilised direct oil cooling for the motor during high speed operation which resulted in a low profile, compact drive system that permitted hub mounting (Figure 10). The design simplified chassis and suspension design without compromising the availability of regenerative braking. This type of design opened new doors to performance electric vehicle development and the project expects to further this research in future years.

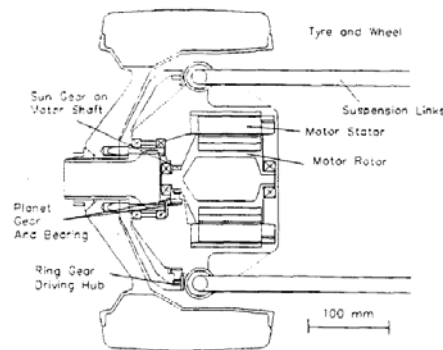

Figure 10: Motor / Hub Assembly (Monkhouse *et al.* 1993)

Electric cars can further be adapted to low range, ultra high speed applications such as setting land speed records. Ohio State University's "Buckeye Bullet" is the world's fastest electric car, and set international land speed records in 2004 (McQuin, Davis & Rizzoni 2006). This paper discusses the three aspects of the electrical drive train: energy storage, electrical power conversion, and electromechanical power conversion, with the later expanding on previous work by Berman & Gelb (1974). The paper also discussed the tuning of the inverter-motor drive interaction in achieving a smooth acceleration profile. This type of research will be essential to REV in conditioning the performance of the car to the environment, but is likely too complex to further at this stage.

## 2.2 Power, Battery and Efficiency

The feasibility of electric cars has a high interdependence on the battery technology of the time, which defines the range and performance capabilities of the vehicle.

Studies can find that a car in the United States with a daily range of 132 kms can meet the needs of the owner on "95 percent of the days of the year" (Schwartz 1977). Increasing this range further does not make the car necessarily useful because intercity travel is still not possible on a single charge (Schwartz 1977). The following work will aim

to refine this figure using Australians commuter transportation statistics. This will define our range requirement (see Section 4.2.3).

While using newer battery technologies can increase our capacity for performance, the energy efficiency of the car determines the rate useful work per quantity of energy. To get better performance out of the vehicle we need to design for efficiency.

"Power management in electric vehicles" (Jefferson 1993) discusses the requirements of design to maximize the power to weight ratio of the vehicle. It defines a modular electrical design for the car and denotes the engineering constraints of the vehicle subsystems. Presented is an optimal design of a primary power source and energy storage facility.

Further, using electrical power to directly drive vehicular subsystems such as heating and air-conditioning has advantages in instantaneous response as well as efficiency (Miller et al. 1999). The research further presents advancements in power electronics, electric drives and control electronics that improve the performance of automotive electrical systems.

Through the implementation of an effective regenerative braking system, the car can increase efficiency by recouping a significant component of power expenditure normally dissipated as heat during the braking process. Ding *et-al* (2007) present a regenerative braking system that utilises a hydraulic accumulator, so that energy regained from braking can be used to make the motor start with low current from stop. Typical methods include reversing motor action through the controller and feeding excess energy to an ultra-capacitor bank or back into the vehicle traction battery.

Augmenting traction batteries with power from the sun has also been linked to efficiency increases but has been distanced from electric vehicles, proving to be complex and expensive the long run. The initial rationale was that solar could replenish the power used by the cars while on the move. It can be conceded that solar energy is not a practical solution for satisfying this lack of energy (contributing a mere 2 km of additional range or requiring 100+ days of sunlight to fully charge a typical EV) but this mechanism can be used to power auxiliary vehicle systems provided that the EV operates at low duty cycles in a sunny, predictable environment (Abusleme, Dixon & Soto 2003).

Increasing efficiency also involves generating reliable, systematic and indicative performance analysis of existing subsystems and techniques for increasing the lifetime of consumables (Lukic & Emadi 2002; Oman 1999). This should be a consideration for project work in future years.

## 2.3 Evaluation Modelling and Simulation

In recent years, the availability of adequate battery technologies has not been a concern with a number of products in commercial production (Oman 1994; Oman & Gross 1995). The selection and benchmarking of the appropriate technology now becomes a concern.

Battery evaluation has been conducted with various technologies with a view to select the ideal battery for commercial electric vehicle applications (Joshi & Deshmukh 2006). The primary indicator of battery performance is actual amount of charge held, which depends highly on the charge and discharge rates. These rates are linked to the

performance of electric vehicle and needs to be simulated under various speeds and gradients etc. Previously systems have been developed for the accurate assessment of battery technologies for electric vehicles that utilize high acceleration rates and full regenerative braking requirements of such an electro-mechanical system (Allen et al. 1993).

At present there is very little research that conducts examination into commercially available batteries and their performance characteristics. Independent evaluations by EV enthusiasts (Halstead 2006; Rick 2005) are the only means to discern between the products. The authors iterate the difficulty in accessing the information, with manufacturers often reluctant to provide information beyond the details in specifications.

*"Performance predictions for a single seater junior formula electric racing car"* (Adcock et al. 1993) describes range and performance variations for several configurations suitable for performance electric cars in line with the scope of this project. The results present the configuration and battery system that has the best performance characteristics, as tested on the circuit. The results of this research may be used as a foundation for the technology which REV can build upon.

Further than battery evaluation, little work has yet been found to produce an accurate model of EV performance and operation based on vehicle and part characteristics. The work conducted as part of this thesis will attempt to build such a model utilising the research discussed above.

## 2.4 Control Systems

Sensor and instrumentation systems can be used to allow users to monitor and control subsystems.

A component of this instrumentation is accurately determining the state of charge (SOC) of a battery array. In the past, adaptive battery monitoring systems for electric vehicles have been developed (Sinclair, Duke & Round 1998). The technology however pertains directly to lead-acid battery measurement using non-invasive techniques. It is hoped that concepts described in this paper, with additional research may apply to other, more applicable battery types.

More complete measuring and monitoring systems enable reporting of all values necessary for subsystem and user interaction. These systems can incorporate an onboard computer utilizing a number of slave measurement units to determine current, voltage and temperature values over a vehicle CAN bus (Kuchta & Varba 2003).

Present-day vehicles utilise a number of different control and indicator/alarm systems often operating independently of each other (Figure 11). Systems that utilize a vehicle management unit and battery management system have also been researched in considerable detail (Sharma, Kamble & Sharma 2006). While much of the discussion applies to hybrid electric vehicles, the concepts are portable to the economy electric car design.

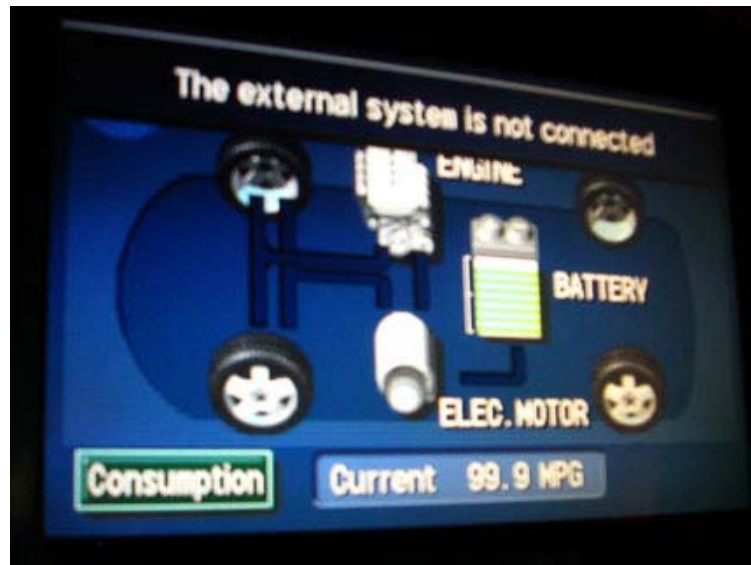

Figure 11: In-Car Computer in Prius Hybrid Electric (Courtesy: Edmunds Insideline)

## 2.5 System Design

The culmination of the technology in a single design solution is presented in "Design and development of high-performance two-passenger electric automobile" (Schwarz 1980) in which the trade-offs in electric vehicle design are highlighted and the rationale behind choices in the design are examined. Schwarz develops an electric vehicle with performance characteristics that include "a 0-48 km/h acceleration time of 10 sec, a top speed of 63 mph, and an operating range of 92 km". This dissertation will expand on the work, refining the requirements and performance specifications to meet the needs of the average city commuter and adapting the design to modern developments to build a performance vehicle that exceeds these benchmarks.

An overview of Project Volta, an attempt on an electric vehicle land speed record is presented alongside a subjective audit of the current level of European technology for high speed electric propulsion (Harrison & Fairhurst 1993). The audit captures a useful snapshot of the commercial technology available and a variety of possible implementations of this technology.

In addition studies have further determined the extent to which various parameters influence electric vehicle performance on various competition vehicle systems, from land speed records to endurance events (Wykes 1993).

Gulhane, Tarambale & Nerkar (2006) present a scope for the research and development of an electric vehicle. The paper conducts a comparative study of motor, battery and control technology as well as discussion into issues regarding promoting electric vehicles as a primary means of transport. The work is very similar to that achieved in this dissertation.

Rizzoni (2005) demonstrates the selection of these parameters in the design, analysis and performance of the "Buckeye-Bullet" (Figure 12). The design occurs with a focus on

developing a vehicle that will satisfy the criteria for obtaining the land-speed record: specialized design criteria which encompass aspects of safety and refuelling are discussed.



Figure 12: Buckeye Bullet at Bonneville (Courtesy: Bath Township Fire Department)

A number of papers discuss the advantage of developing a race car as a platform for engineering education, including the establishment of a competition for University teams to compete at regular racing events (Berry et al. 1994; Wykes 1993). No such event exists in Australia, but the project hopes to develop a competitive electric motorsport group, similar to the Formula SAE class UWA Motorsport Team.

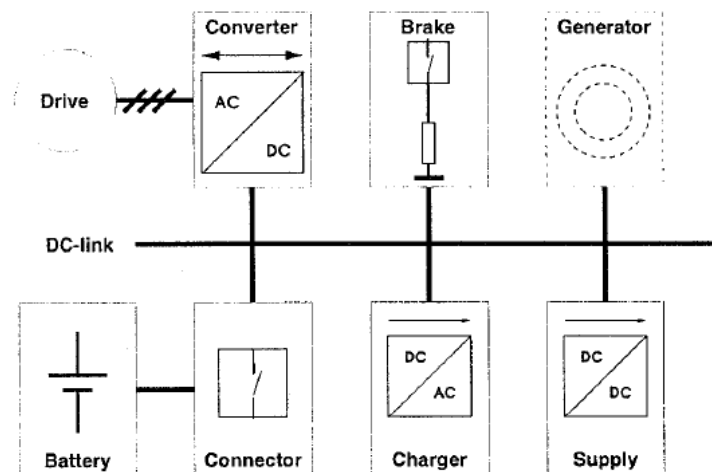

Figure 13: Power Electronics Function Blocks of an EV (Vezzini & Reichert 1996)

Vezzini & Reichert (1996) describe developing the system using function blocks (Figure 13), in the style of top-down-design. The paper further outlines the major function blocks and the requirements / major solutions. Maggetto & Van Mierlo (2000) present a design using similar methodology, outlining key components of the electric vehicle and hybrid variations. The paper presents in summary the material presented in the following dissertation – an overview of electric vehicle design principles.

## 2.6 Range of Present Work

Present work has:

1. Provided an in-depth overview into the history of electric cars and their components, evolution and principles.
2. Verified that they are technologically feasible and a viable form of transportation for the majority of use.
3. Verified that they are capable of working with present day power distribution systems, including renewable sources of power.
4. Presented a number of implementation ideas for power, drive-train and control system design.
5. Demonstrated the growth of electric vehicles as a form of transportation and,
6. Demonstrated the capabilities of the electric vehicle under commercial, performance and high-performance applications.



# 3 Project Management

---

The following chapter discusses the project logistics and management. Included will be a brief discussion of the initialisation of the project: particularly materials, grants and sponsorship acquisition. Additionally the chapter will discuss the established REV development process,

The REV Project began in July 2004, inspired by projects such as Tamagawa University's Solar Car Project, with a focus on building a hydrogen fuel cell vehicle. Since its inception, the project failed to produce a complete solution beyond the development of components for data acquisition and select components of a hydrogen fuel cell. This is attributed to the relative complexity of the hydrogen fuel cell vehicle design discussed earlier.

In 2008 the project was restarted under the supervision of A/Prof. Thomas Braunl with a renewed focus: to develop two vehicles by the end of the year - a performance and commuter electric car. The goal required strong and focused project management to avoid the delays that plagued the project in previous years and achieve results within the 7 month deadline.

The project utilised a variety of materials and resources and relied on sponsorship, grants and external funding as its source of income. An outline of these resources is provided in this chapter.

## 3.1 Materials Acquisition

Parts, tools and equipment from the discontinued hydrogen car project were made available to the reformed project. The commuter car utilised as much of this technology as possible in order to reduce lead time and capital costs associated with development.

In addition to existing resources, the project made a number of purchases to complete the proposed solution.

An inventory of parts acquired from previous work on REV is provided in Appendix A.1. Additionally an inventory of parts purchased for REV 2008 is provided in Appendix A.2.

## 3.2 Sponsorship

As a means to reduce costs the project operated with suppliers and manufacturers with a view to attain sponsorship. The project offered organisations a chance to get involved with a sustainable transportation project by exchanging marketing opportunities (namely logos on car and promotional material) for project funding or through the donation or discount of parts.

A list of REV Sponsors engaged in 2008 are listed in Appendix A.3.

### 3.3 Grants and Other Funding

The REV Project relies heavily on grants and funding in order to acquire, develop and integrate vehicle components into the vehicles. In order to increase our opportunities for grant based funding the project has been required to adapt to play a more integral role in the community by educating the public about principles of electric vehicle design, sustainable transportation and promoting engineering as a profession to primary school students.

There has been no significant grant based contributions to The REV Project this year. It is hoped that in future years, with a tangible outcome (REV Eco) and support from the School of Electrical and Electronic Engineering that there will be further interest in the vehicle to warrant funding.

### 3.4 Development Methodology

From a macroscopic (2-3 year) perspective, the project will apply the Spiral model Development Methodology as the development lifecycle. The model is derived from software engineering principles and is especially suited to large, complicated and expensive projects and combines elements of design and prototyping (Figure 14).

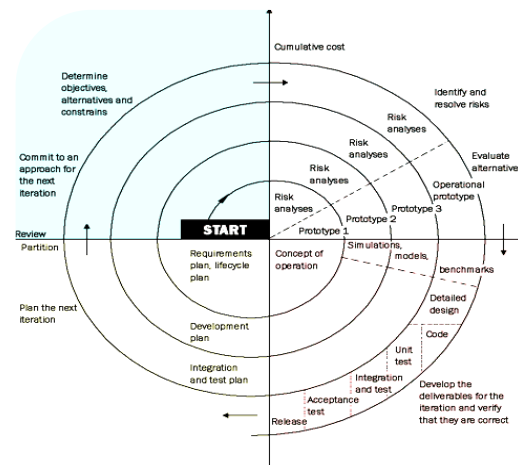

Figure 14: Spiral Model of Design (Courtesy: Elman)

The focus is on short term (1 year) results, with each successive stage improving on the past prototype. Within the year development will focus on improved performance and extended functionality.

This model is similar to that used by the UWA Motorsport team, which integrates improvements in design into a new model vehicle each year. The result is a fleet of successful Formula SAE vehicles.

Since the project attempted to develop two vehicles, members were allocated a project that involved immediate technical development as well as a similar or related project that required further research, design and long term development. Project allocation was done with consideration of personal ability, field of expertise, project duration and

urgency. Sub-projects were left to the students to manage within internal teams. All sub-teams chose an ad-hoc approach to development.

### 3.4.1 Meetings

There were two meetings weekly throughout the duration of the project; formal and informal.

**Formal:** Formal meetings would allocate task and discuss project generalities, administration, issues that involved sub groups, deadlines and reporting (Figure 15).



Figure 15: Formal meetings for task allocation and reporting.

**Informal:** Informal meetings were to consult technical staff and further discuss sub projects, overview project progress and handle to issues early (Figure 16).

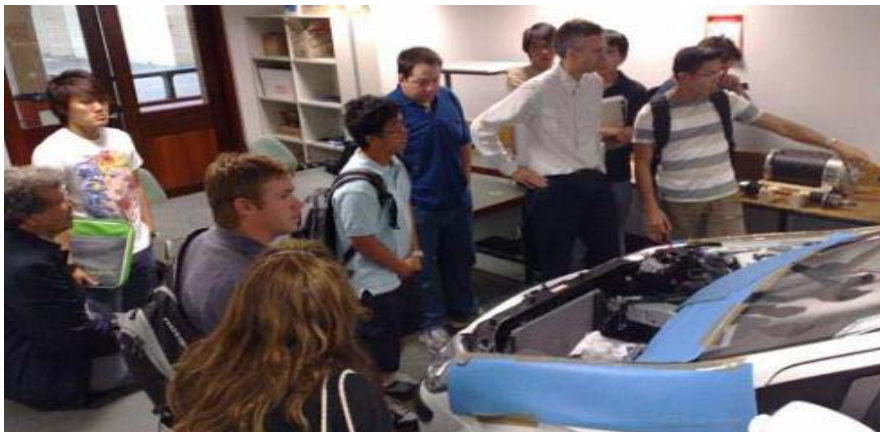

Figure 16: Informal meetings for technical consultation and issue resolution.

Initially, attendance at both meetings was strongly recommended to students, but as attendance fell delegation of tasks became difficult. In second semester attendance contributed to the initiative component of assessment.

### 3.4.2 Task Allocation and Reporting

In the first semester, task allocation was a loose process, relying strongly on the initiative of group members. Only group members who attended meetings could then be assigned tasks. As a pattern of neglect occurred, responsible group members took over neglected tasks. The distribution of work became unbalanced and some tasks were not completed.

In order to overcome this during the second semester, task allocation became strongly defined. Team members were allocated into groups tasked with a sub-project. Sub-projects were broken down into a number of tasks and deadlines. It was the responsibility of group members to get the tasks completed and report on progress at the deadlines.

Reporting was in the form of a presentation at the formal meeting. Technical and management personnel were able to provide direction with further consultation occurring after-hours. Reporting formed a component of initiative assessment.

### 3.4.3 Scheduling and Delays

While it was initially proposed that the project would aim to develop both vehicles (performance and commuter) within the year, difficulties developing designs for a performance vehicle as well as a number of other delays (outlined in Section 3.4.3) resulted in severe alterations to the initial scheduling.

It was later proposed that development of the performance vehicle would occur in 2009, with the focus in 2008 being the completion of the development of Eco.

There were three significant types of delay experienced by the project:

**Part Acquisition:** Due to the lack of an inventory from previous years a number of parts and resources were misplaced and unavailable for use in the project. This coupled with delivery times for parts (including Power Steering, A/C and Brake Assist which were only available from US or UK suppliers) caused a number of prolonged delays.

**Personnel Delays:** Many students undertaking REV project work also had a full academic load (Figure 17). This in-turn lead to additional difficulties in communication, tasking and meeting. New students experienced a period of 2-3 weeks downtime before becoming productive members of the team. Finally, a number of students were absent or unproductive during the holiday period contributing to a month of downtime.

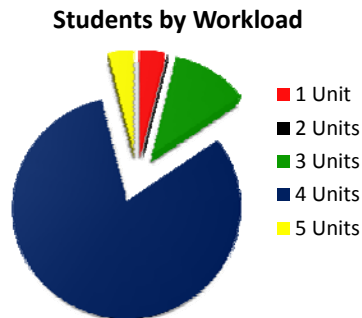

Figure 17: Student Workload Distribution

**Workshop Availability:** The project relied heavily on availability of the workshop personnel for consultation and development. Because these personnel were tasked with other projects there was often a delay before work could be conducted.

**Delay of Lotus:** The shipped Lotus Elise was delayed for a period of 8 weeks (and counting) waiting on components for conversion to Australian specifications. Components for the Lotus had to be ordered directly from the U.K manufacturer.

**Workshop Delays:** The project workshop was not able to house two vehicles and without further modification to the door frame was not accommodate the width of the Lotus Elise. These modifications are considerably expensive and time consuming.

### 3.5 Team and Development Process

Project team members consisted of staff, technicians, undergraduate students and volunteers. A full team list including is included in Appendix A.4.

**Staff:** Primarily took on supervisory and management roles relating to project organisation, academic consultation, project direction, marking and sponsorship.

**Technicians:** Often the fabrication, design and dismantling of components was beyond the ability of project personnel or were better developed by experienced personnel. These tasks were undertaken by technicians.

**Undergraduate Students:** Students who had an active interest in the project could utilise it to form a component of their university assessment.

**Volunteers:** Volunteers included members from industry and academia and also included undergraduate students interested in the project. Members participated in simpler time sensitive tasks such as grant applications, quotes, part installation and consultation.

A customised development process was used to allow students to meet with project supervisors and team members and to report individual progress. The development process used by the team is illustrated in Figure 18.

The project director and student manager would meet to discuss the design with the consultation of Technical members and student input. This was refined into a list of tasks

or sub-projects. Requirements for the task were further formalised by the project manager. At team meetings students and sub-teams groups were allocated tasks. Groups were then permitted to subdivide tasks further internally.

Groups and individual team members were able to discuss the requirements of the task further with the Project Manager as well as workshop and technical staff.

Alongside the requirements of the tasks, team members were encouraged to consider the legal, environmental and commercial requirements of their task and research the application further to develop a solution. Team members were able to utilise the expertise of workshop and technical staff in the production of their design. The results of their investigation as well as the proposed design were presented to the entire team in formal meetings.

In developing their solutions, team members can either manufacture a custom solution or acquire existing products if viable. The solution is tested, benchmarked, packaged and installed into the vehicle. At each stage in development team members are required to report the progress of their work.

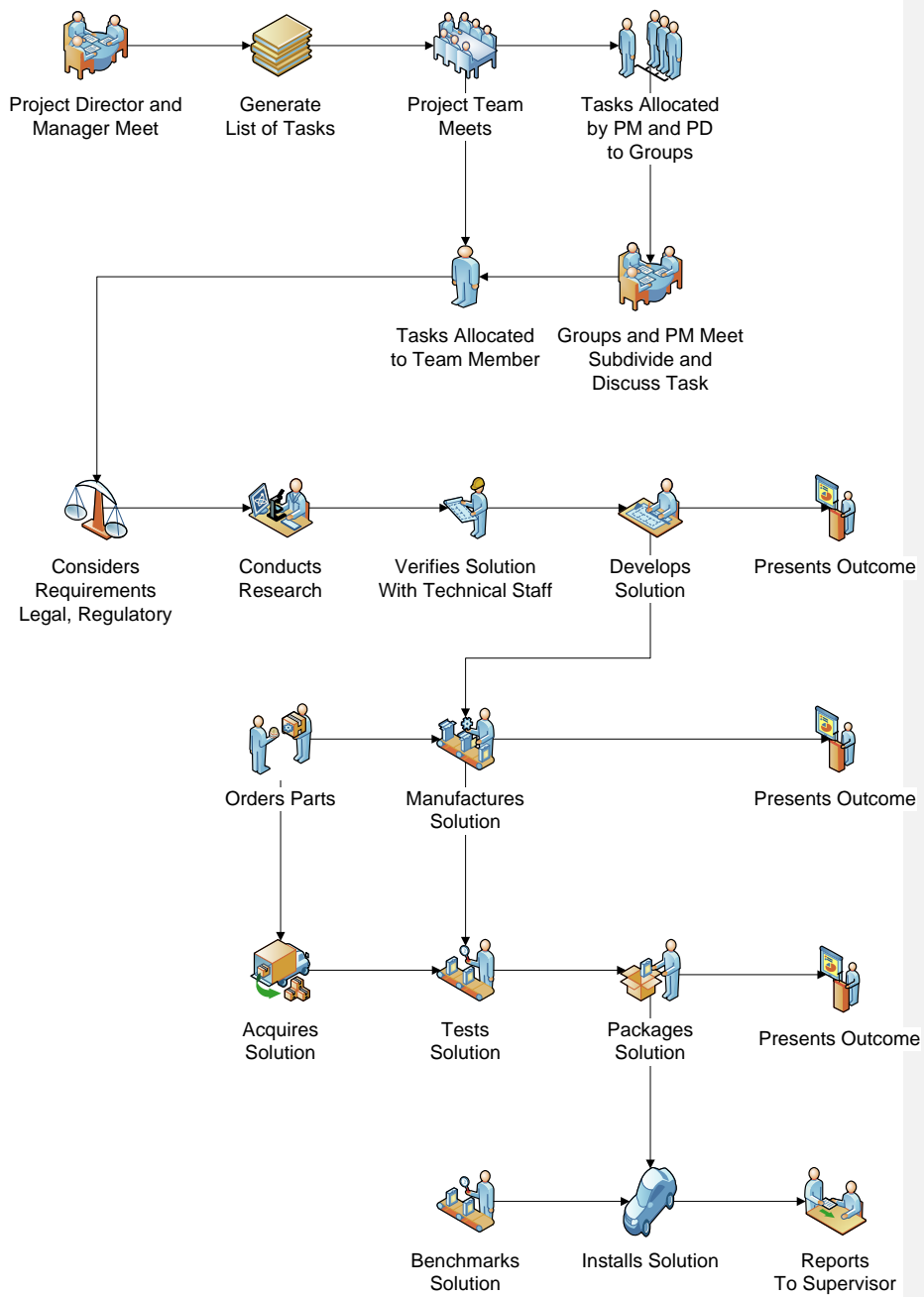

Figure 18: Development Process Flow

### 3.6 Website

The project required an area to advertise its purpose and goals. This area was used to develop sponsor interest in the project and offered a common point where notices could be posted and events could be advertised.

The website (Figure 19) uses the Joomla Content Management System and includes the Community Builder Extension. This allowed users to post and create content without any knowledge of HTML.

The Community Builder Extension allowed users to sign-up to the site and post on the forums. The website also offers a mailing list in which team members can post and receive updates about the project.

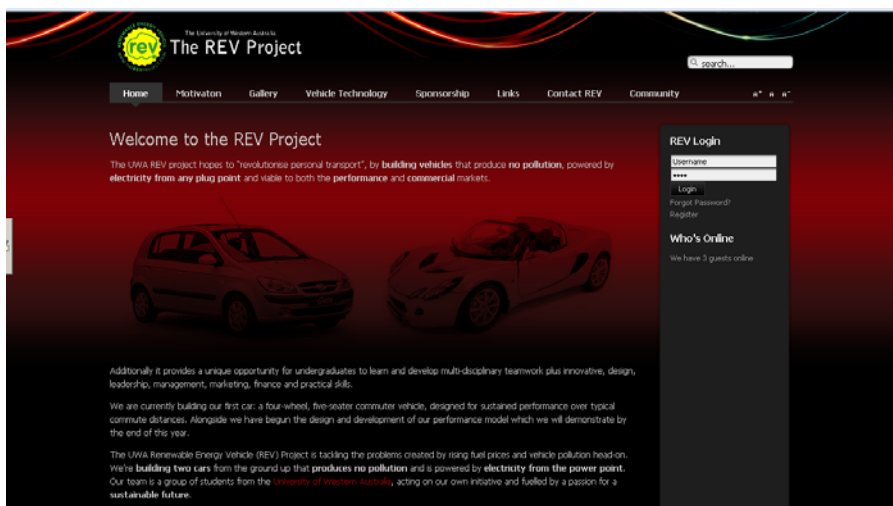

Figure 19: Screenshot of TheREVProject.com

The website is to additionally include a monitoring system that presents solar panel and vehicle charging data and results. This was beyond the scope for 2008, but will be implemented in 2009.



# 4 Requirements Analysis

---

The purpose of the REV vehicle is to transport occupants from one location to another. This will be achieved with a view to maximise comfort and efficiency and minimise environmental impact and expense.

The systems should be robust, efficient and present a commercially viable alternative to fuel, capable of being utilised by any licensed driver without specific training.

The cars will be developed with the intent to reduce consumer cost over the lifetime of the vehicle in order to aid adoption into the market. The system should be able to act as a direct substitute for conventional transportation systems.

This chapter discusses the requirements of two project deliverables: a performance and a commuter electric vehicle.

## 4.1 Aims

In developing the requirements for renewable energy vehicles we need to consider the aspects of the vehicle that make it functional as a means of transportation: specifically, its **range** and **capacity**. We will design the vehicle in order to maximise its range under maximum load.

The duties a specific type of vehicle can perform directly relate to these functional characteristics. It is immediately apparent that because of battery constraints REV vehicles will not be suitable for all applications – we will identify and target REV to specific applications.

Technological factors impose constraints on our design, especially in relation to the power to weight, efficiency, charge density, charge capacity and recharge time. We will attempt to utilise performance technology while minimising costs and developing a framework that is modular and easily extensible.

Finally, requirements analysis will be done with a view to utilise existing components, reduce environmental impact as well as reduce whole of life cost.

The project aims to design and develop vehicles with specific performance attributes targeted at particular tasks, specifically **commuting** and **racing**.

The secondary intent is to increase public awareness of electric vehicles as an alternative means of transportation for niche applications such as commuting.

## 4.2 Functional Requirements

The following section identifies and discusses the functional requirements of the system. Functional requirements are objectives that the project deliverables are tasked with achieving, in order for it to be considered a viable solution.

### 4.2.1 Power Generation

The system must be powered from an environmentally sustainable and economically viable source, with minimal production and tailpipe emissions. There are a number of viable alternative fuels available and a summary of research has been tabulated in Appendix B.1.

Specific research into the viability of different alternative fuels is beyond the scope of the work presented here, but a significant number of other works in the field have argued the advantages of electric vehicle technology over other alternative fuels (Blaabjerg et al. 2005; Gulhane, Tarambale & Nerkar 2006; Olken 2004; Sulzberger 2006; Young 1994). The primary reasoning behind this is the understanding that the electric car can transfer the responsibility of sustainable power generation to the power grid. In the short term, there will be reduced gains as consumers choose to power their vehicles from coal based sources. In the long term, as the power grid becomes more efficient and transitions to cleaner sources, these vehicles will also be able to transition seamlessly.

Both EV vehicles in this project will be **grid powered plug-in electric vehicles**.

### 4.2.2 Capacity

**Commuting:** The REV commuter vehicle will require seating for five occupants, including one driver (Figure 20).

The rationale behind developing a five seater commuter car was a commercial and environmental decision as well as one of practicality.

The commuter vehicle developed will be, in future, the host to a variety of onboard sensory and computation equipment. The technology may be distributed around the vehicle and in order to access and install these rear vehicle doors are required.

Car occupancy rates, while presently low (1.4 persons per car, per trip) have a significant impact on emissions. A 10% increase in cars carrying a second passenger would lead to an emissions reduction equivalent to a two-fold growth in public transport patronage (Stanley, Currie & Stanley 2007).

Consumers also prefer the flexibility of a five seater car for comfort, space and the option to transport more passengers, with 24% of those surveyed rating the seating configuration as vital consideration to their purchasing decision (Johnson-Controls 2005).



Figure 20: Interior of Hyundai Getz (Courtesy: Hyundai)

**Performance:** The REV racer vehicle will require seating for two occupants, including one driver.

Race cars are typically two seater vehicles built with a focus on weight reduction, which in turn improves handling characteristics. In long distance competitions, performance cars require a pillion seat for a navigator.

### 4.2.3 Range and Efficiency

Due to the characteristics of present battery technology and its low energy density, it is unlikely that an electric vehicle could directly compete with a combustion engine in terms of vehicle range.

This project recognises the strong coupling between battery technology and vehicle range. The REV will utilise existing products with an understanding that commercial battery technology will improve in subsequent years and strongly affect the end performance of the vehicle.

If the project distances itself from battery development and focuses on the development of an efficient grid-to-battery and battery-to-wheel system, any subsequent developments can be simply replaced (plug and play) in future years. Selection of appropriate battery technology will be discussed further in Section 5.2.4.

Development of REV vehicles will occur with a view to maximise vehicle efficiency and range at all times. In this section we aimed to define a *minimum* range for the practical viability of an electric commuter vehicle.

Table 1: Total Kilometres Travelled by State/Territory of Registration (Courtesy: ABS)

SELECTED PERCENTILES (a), State/territory of registration—Type of vehicle

	20th Percentile	40th Percentile	50th Percentile	60th Percentile	80th Percentile	95th Percentile	99th Percentile
TOTAL KILOMETRES TRAVELLED							
<b>Passenger vehicles</b>							
New South Wales	1 126	2 435	2 895	3 362	5 100	9 077	11 374
Victoria	1 083	2 379	2 891	3 435	5 495	8 853	13 610
Queensland	1 386	2 523	3 189	3 777	5 429	9 152	12 051
South Australia	1 044	2 091	2 537	3 138	4 962	7 996	12 581
Western Australia	1 156	2 292	2 732	3 300	4 822	7 196	14 055
Tasmania	937	2 148	2 698	3 094	4 782	9 131	15 316
Northern Territory	1 298	2 058	2 568	2 998	4 967	9 057	13 968
Australian Capital Territory	1 398	2 329	2 979	3 548	4 900	7 513	9 499
Australia	1 168	2 376	2 890	3 443	5 218	8 853	12 441

In the highest (99<sup>th</sup>) percentile of cases, Tasmanian drivers achieved around 15,500 km of travel in a year (ABS 2007) (Table 1). In rounding this figure, we account for high end variations in usage, including travel between multiple places of residence or occupation.

If we assume that most passenger vehicle travel is primarily comprised of commuting, we can further characterise the nature of this travel on a daily basis:

- Trips are distributed evenly year round.
- Trips are approximately equidistant and round trips.
- Trips occur on weekdays (normal commute) and weekends (utility / leisure drive)

$$\frac{16000}{356} = 44.94 \approx 45 \text{ kms/day}$$

Deviations from this assumption could occur:

- Holidays (typically 4 weeks a year):  $4/52 = 8\%$  deviation
- One-of trips (assumed 24 times a year):  $24/356 = 7\%$  deviation

The tolerance of this range value is  $\pm 15\%$ .

Thus, to satisfy the daily needs of the significant majority of passenger vehicle owners, specifically commuters, the REV commuter vehicle would require a range of **45 to 52 km**. Figure 21 shows the operating range of the vehicle.

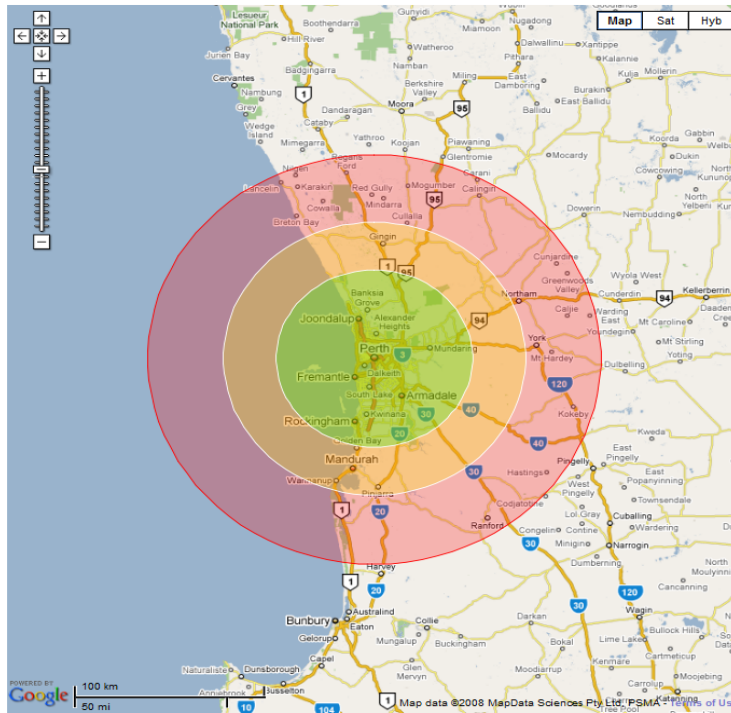

**Figure 21: Servicing Range of a 80-120km Commuter Electric Vehicle**

Green and Orange areas indicate the minimum and maximum round trip range (Trip distances are measured from City Centre: 40km in Green, 50km in Orange). Red indicates the maximum one-way range of the vehicle (From City Centre: 120km in Red).

Figure 21 shows that the vehicle can be used by a significant proportion of the population for the purposes of commuting between work and home in the Perth metropolitan region. Users in the green region may be able commute between places of work and social activities, while users in the yellow region may need to charge their vehicles further at work to achieve the same outcome. Users in the red region would still benefit from commuting with the vehicle but it would be vital that the vehicle was charged before the return journey.

Since electric vehicles have no specific racing constraints or guidelines - due to the relative absence of competition for electric cars, we will define no range requirements for the performance vehicle other than to maximise effective range.

In the long term, the project intends to maximise the efficiency of the car, where as in 2008 the focus was to establish infrastructure capable of efficiency improvement through modification and intelligent control.

In the long term aim of the REV project is to achieve efficiencies close to that of the traction motor of the vehicle. This implies that losses between plug-point and drive train will be minimised.

#### 4.2.4 Cost

To remain competitive in the global market the final product must be able to compete with similar vehicles of its class in terms of total vehicle ownership cost.

A significant component of this cost is capital expenditure on battery technology – a cost expected to diminish as battery technology improves (Richard 2008). Costs are estimated to be approximately 25% of vehicle cost.

Since manufacturers benefit greatly from automation and consequently economies of scale, cars manufactured today cost far less than the sum of their components. Additionally, manufacturers can absorb one-off costs involved in design, prototyping and fabrication over the volume of vehicles produced. For this reason it is unlikely that the REV vehicles produced in a one-off environment would be able to compete in price.

Finally, the cost should not exceed consumer budgets for a new vehicle.

There are four major costs for vehicle owners:

**Vehicle Cost:** Cost of the complete solution should be less than 300% of the cost of a conventional vehicle of a similar class.

**Fuelling Infrastructure Cost:** Since electric cars require frequent refuelling, we intend to minimise the cost of fuelling and distribution infrastructure.

**Operating Cost:** The vehicle should be cheaper to refuel and operate than conventional gasoline or derivative technology.

**Maintenance Cost:** The cost of maintenance, and long term outlay should be minimised.

#### 4.2.5 Renewability

In order to be sustainable, the source of fuel for the REV should be renewable. A resource is classified as renewable if it can be produced naturally at a rate faster than it can be consumed.

Since some renewable resources have to be managed carefully to avoid exceeding natural capacities, the project will attempt to utilise perpetual resources such as solar power.

#### 4.2.6 Sensors and Control

The project will require a control system capable of intelligently monitoring and driving components in order to facilitate quality in performance and comfort for passengers.

**Monitoring:** The system should be able to provide the driver with the following vehicle status and performance metrics:

- Speed
- Motor Rpm
- Battery charge condition
- Distance and Navigation information

- Range metrics

Additionally, the system should be able to determine the faults, warnings or critical states within the vehicle.

In the long term the system should be capable of affecting change within subsystems.

**Control:** The system should be able to control, through user interaction:

- Battery charging characteristics
- Motor performance
- Instrumentation (indicators, lights and wipers)
- Environment (climate control and seat positions)
- Drive-by-wire

### 4.3 Non-functional Requirements

The project will attempt to use resources that have minimal environmental cost. This cost can be incurred through:

- The production of the part and components that form the part.
- The production of the resources that from the components.
- The installation of the part.
- The operation, wear and maintenance of the part.
- The disposal of the part.

It is important to note that the project itself will use a variety of resources during development that impact significantly on the environment, especially during the formation of the first iteration of the vehicle(s). Ideally, the completed solution will be presented after examining the cost of life analysis on all parts and processes involved.

Computer control systems and instrumentation will provide accurate and informative drive metrics and will aid the driver in the operation of the vehicle subsystems. The systems developed should be easy and intuitive to use, with little to no specialised training required.

The finished modified vehicles will continue to comply with relevant vehicle standards including the latest Road Traffic (Vehicle Standards) Regulations/Rules and the Australian Design Rules (ADRs) (ADR 2006). The ADRs are construction and emission standards applying to motor vehicles intended for use in transport in Australia.

Modifications will be conducted under the "Code of Practice for Light Vehicle Modifications" (VSB14 2008). This code was developed to assist owners to perform safe and legal modifications. The full code of NCOP Rules and Regulations is included in the Disk Media attached.

Vehicles will be formally licensed and registered before road testing to ensure that they comply with these standards. Registration will be conducted through the Department of Planning and Infrastructure, Western Australia.

# 5 Eco: Commuter Design

---

This chapter outlines the proposed design for an electric commuter / short-medium distance passenger vehicle for inter-city travel. The design of the electric commuter vehicle was oriented around the conversion of a typical commuter vehicle. Through conversion, development time and costs were significantly reduced.

Additionally, conversion offered a base line to compare the performance of the vehicle. The proposed design formalised the conversion process.

The conversion process involved the extraction of the internal combustion engine and combustion related components from a donor vehicle. The vehicle was then fitted with an electric traction motor and battery system. Auxiliary systems were modified as necessary to operate in the vehicle.

**NB:** Specification sheets for components and parts mentioned below can be found in the disk media attached.

## 5.1.1 AC / DC System Selection

The commuter vehicle operated as a DC system. DC Systems are characterised by:

**Quick Setup Time:** Parts are readily and commercially available through EV part suppliers - this is the technology of choice for most conversions due to its relatively low cost. Additionally, the parts available from previous years work were DC system components.

**Low Cost:** DC motors and controllers are cheaper and can be purchased independently (AC motors are usually paired with a specific type of controller). Additionally because these systems operate at lower system voltages, fewer batteries are required, which reduce battery expense.

**Easy Controlling:** DC controllers require little to no programming or configuration for the setup of control – independent components can work out-of-the-box.

**Low RPM Torque:** Series wound motors have much higher torque at lower RPM while AC systems require gearing down. This characteristic is particularly desirable for conversion of a commuter vehicle that is subject to start-stop operation in areas with high traffic light density.

## 5.2 Traction Systems

The following components comprise the main traction system of the REV Eco, the name given to the electric commuter vehicle:



### 5.2.1 Donor Vehicle

The electric vehicle was to be based on an early model **2008 Hyundai Getz Series 1.4 S**, five door, five speed manual - a popular super-miniature class, passenger vehicle (Figure 22).

The five seater vehicle was chosen to satisfy the requirements (outlined in Chapter 4), for its low cost, standard feature set and typical commuter vehicle profile.

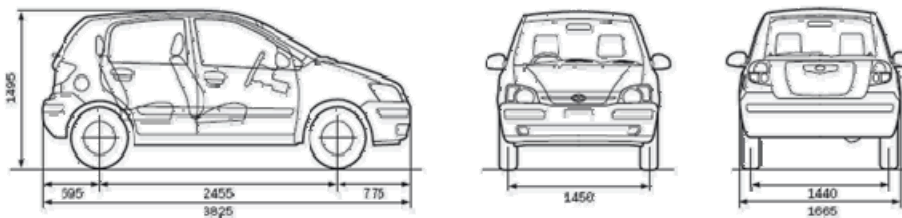

Figure 22: Hyundai Getz 2008 Size and Dimensions

The vehicle was ordered including air conditioning, power steering as well as passenger and driver airbags but without ABS in order reduce the complexity of conversion.

### 5.2.2 DC Motor

There are a number of different types of DC Motor:

- Permanent Magnet
- Series
- Shunt
- Separately Excited

With the exception of the permanent magnet type, which uses fixed magnets, all motors utilise field coils in the stator to generate a magnetic field for the rotor to spin in, with their names specifying the way coils are wired with respect to the rotor (Figure 23).

All four types use a commutator to polarise the appropriate winding and maintain rotation. The commutator mechanism is the main source of inefficiency and requires replacement every 100,000 km.

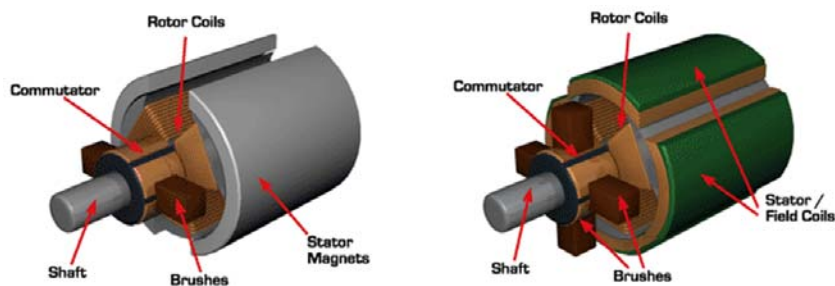

Figure 23: a) Permanent Magnet and b) DC Motor with Wound Stator (Hooper 2008)

An alternative to this commutator arrangement is the Brushless DC which has permanent magnets in the rotor (as opposed to the stator) and electronically switches the field coils (Figure 24). Due to the large permanent magnet used in the rotor and the added expense of the speed controller, the technology is prohibitively expensive at present for use in a commutator electric vehicle.

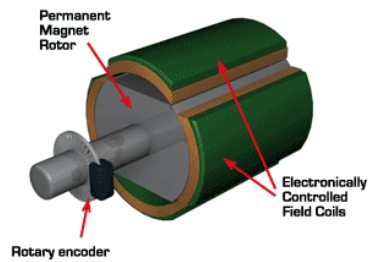

Figure 24: Brushless DC (Hooper 2008)

The REV Commuter vehicle utilised an Advanced DC FB1-4001A Series Wound Motor. The motor has been used successfully in both racing and heavy electric vehicles in the past and is capable of generating up to 100 hp. The motor is shown coupled to the existing transmission of the vehicle and mounted to the vibration damping pads (Figure 25).

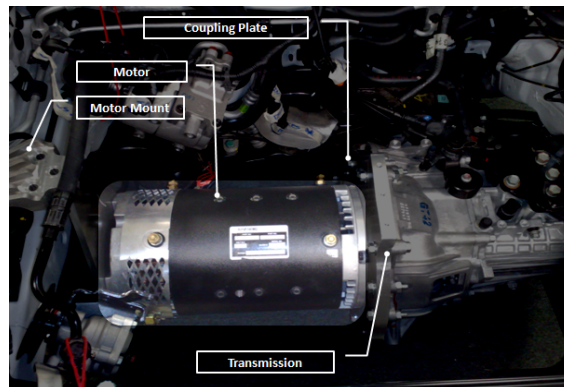

Figure 25: Motor Configuration in Engine Bay

### 5.2.3 DC Controller

Modern motor speed controllers utilise microprocessor analysis of sensors to drive a preamplifier, which in turn drives a power stage amplifier (comprised of either MOSFETs or IGBTs) which controls the power transferred from the battery to the motor (Figure 26).

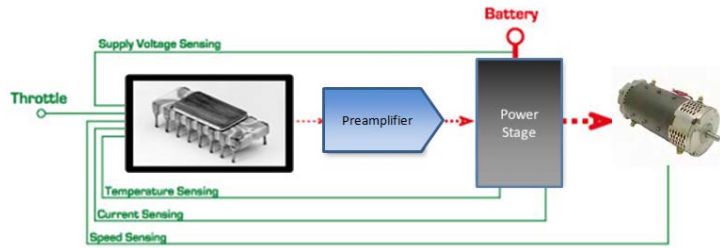

Figure 26: Topology of a Modern Motor Speed Controller

Controllers typically use Pulse Width Modulation to vary the voltage seen by the motor. The modulation (blue in Figure 27) occurs through switching of the interconnection between the source and the load at high frequencies typically 15-20 kHz (green).

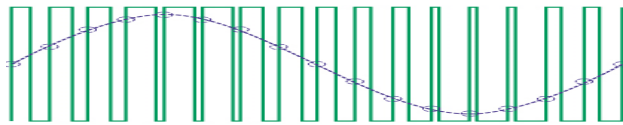

Figure 27: PWM of Motor Voltage

Switching at this frequency is almost inaudible to human ears (which can typically hear between 20 Hz and 20 kHz). The high frequency of the noise combined with the muffling characteristics of the combustion engine bay design will mean that the vehicle would appear almost silent in high RPM operation.

The 1231 controller utilised (Figure 28) is prone to a design defect in which the FET driver for the 19 internal IXTH50N20 MOSFETs is positioned inadequately: The PWM signal propagates from the driver reaching the nearer FETs fractionally faster (Hooper 2008). If the motor being driven has high inductance there can be a surge in current in the nearer FETs beyond their rating.

In an attempt to resolve this the 1231C models used frequency shifting to reduce the operating frequency from 15 kHz to 1.5 kHz for low PWM output (typically less than ~15%). This improved current limit control and helped protect the controller when the motor was at near stall conditions. This meant that a high pitched noise was heard at low RPM.

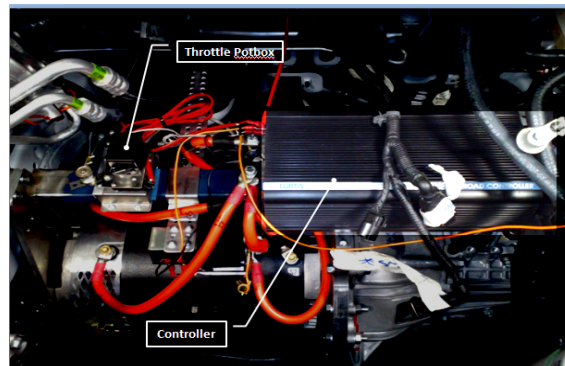

Figure 28: Controller Configuration in Engine Bay

## 5.2.4 Batteries

The characteristics of the battery are the critical factor in the performance of the vehicle. In selecting the battery we needed to consider the following:

- Cost
- Required system voltage
- Power/weight ratio
- Cost/power ratio
- Charging time
- Lifetime, duty cycle and performance degradation
- Environmental cost
- Physical configuration and weight distributions
- Limitations imposed by the suspension and handling of the donor
- Charging and management hardware costs

It is important to recognise the limitations of battery technology:

1. Battery technology, while rapidly improving, is not comparable in energy density to traditional hydrocarbon or natural gas based fuels which have densities ranging from between ~13 and 34 kWh/kg (Figure 29) (Allen et al. 1993). The best battery technologies today (Cobalt based Lithium Ion / Zinc Air) have energy densities around 0.2 kWh/kg (Joshi & Deshmukh 2006). This limitation means that an electric engine holding 250 Kg of battery and operating at 98% efficiency (49 kWh) would only be able to travel 63% of the range of a vehicle with a 45 Litre gasoline tank operating at 20% efficiency (77.5 kWh<sup>1</sup>).

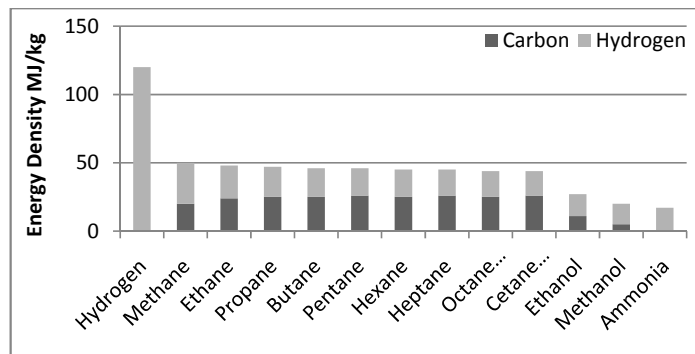

Figure 29: Specific Energy of Hydrocarbon Based Fuels - Adapted from Thomas (2003)

2. Present day batteries have a finite life-span dictated by their cycle life – a figure which typically represents the number of times it is possible to drain 80% out of the battery. Battery management systems can extend the life of the battery through

<sup>1</sup> (31MJ/Litre<sup>[3]</sup> \*45 Litres\*0.2 =279MJ = 77.5 kWh using 1 kWh = 3.6 MJ.)

proper treatment of the battery (see Section 5.2.5) but this effect is marginal (Allen et al. 1993). After this duration, the battery unit needs complete replacement. With poor treatment (overheating, rapid charging/discharging) the batteries are subject to shorter life spans.

Given these two considerations it is unlikely that today's battery technology is sufficient to produce robust, long range or high load bearing production vehicles – however, with correct battery selection we were able to develop a vehicle to satisfy our specified range requirements for the task of commuter transportation.

Comparison was made difficult by the lack of information from manufacturers and intricate costing from suppliers. Suppliers additionally provided volume discounts. Ordering internationally meant that prices were affected by shipping costs, currency fluctuations and global demand. Finally, statistics like cycle times and operating range varied depending on the rigour of testing.

This type of testing was a complex issue and outside the scope of work presented here. Instead, a basic compilation of battery types and brands was developed from a number of online sources (Appendix B.2). From the information available it appeared that the Thunder-sky Lithium Ion LFP-90AHA batteries provided a good balance between power-to-weight and cost-to-power as well as very high charge/discharge efficiencies.

To achieve the required system voltage, 45 batteries (at 3.6V nominal) were used in a series configuration. In addition, a battery cage (Figure 30) was constructed to house and protect the individual cells, charger, management system and fuses. A simple wiring layout of the battery system is shown in Figure 31 <sup>ii</sup>.

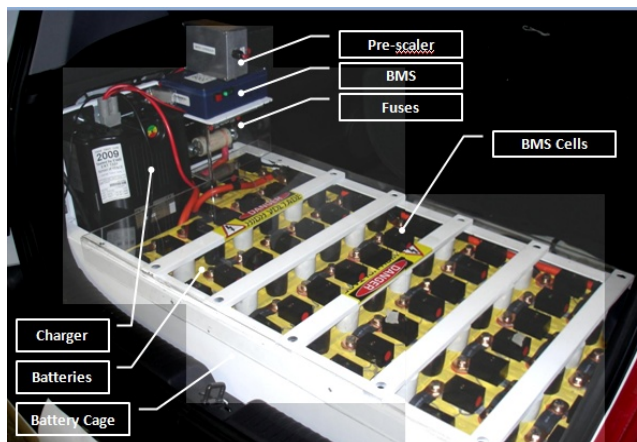

Figure 30: Battery Configuration in Boot

<sup>ii</sup> The diagram is not indicative of physical topology – changed so that the battery configuration can fit in the rear of the vehicle.

## 5.2.5 Battery Management and Monitoring

The Lithium Ion Traction Battery System within the EV is made up of 45 monitoring cells connected in series (Figure 31). Because each cell had a slightly different capacity, due to manufacturing tolerances and environmental conditions, the state of charge in different cells can become unequal, or “unbalanced”, over time.

This is undesirable because the array of batteries no longer perform as a single unit and thus cannot be used (charged / discharged) as a whole. Over a number of charges, the battery array could have some elements requiring charging while other elements were near full capacity. Continued discharging of undercharged batteries or charging of overcharged batteries affects the lifetime of the battery (Doerffel & Sharkh 2006).

The Battery Management System (BMS) served three main functions:

1. The BMS prevented overcharge/overheating/excessive discharge of the batteries by controlling the current to the battery charger.
2. The BMS unit provided a simple interface to monitor battery metrics typically comprising of:
  - a. The temperature of the pack (not used)
  - b. The voltage of the pack
  - c. The amperage of the charge and discharge
3. The BMS used battery information to adjust the charge going into *each* battery (battery balancing).

While some battery technologies are more resistant to abuse than others, all batteries benefit from having a battery management system (BMS henceforth) to ensure they work within their operating parameters. Lithium based batteries require BMS because they can be damaged if overcharged and discharged.

REV Eco utilised a BMS which had been specifically developed for use with the Thunder-sky LFP series, the EV-power TS90. The TS90 comprised of 45 monitoring cells, one for each battery, and a Master Control Unit (MCU). The cells were positioned above each battery and monitored the voltage of each cell in the array (see Figure 31). The monitoring cells were connected in a daisy chain (one-wire interface) and reported to the MCU. The MCU also regulated the power to the battery charger, cutting supply when the battery voltage reached capacity.

As well as a visual (red/green LED) indicator on each cell, the TS90 MCU emitted an internal alarm in the event of any failure.

The BMS interfaced with the TBS Expert-Pro battery fuel gauge, to provide battery metrics to the driver. Additionally, an adapted fuel sensor reported on the state of charge of the battery to the original car dashboard.

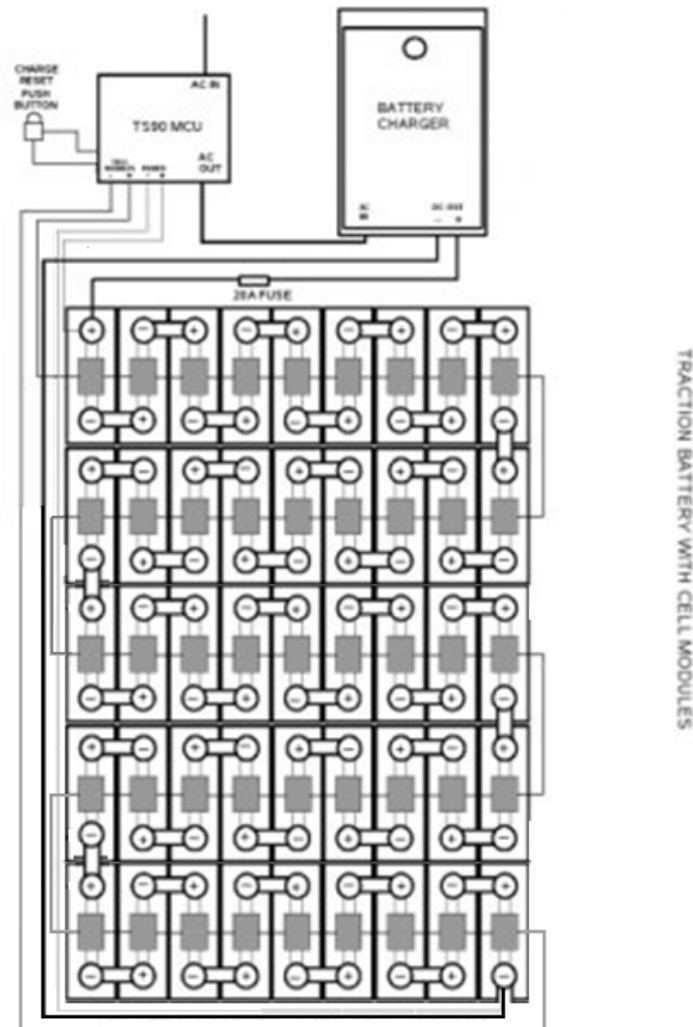

Figure 31: TS90 Battery Management System Connections

## 5.2.6 Battery Charging

The charging of the traction battery was achieved through the Zivan NG3 Battery Charger - a high frequency, high efficiency battery charger that operated on single phase 230 VAC (mains power). The charger was microprocessor controlled and internally protected against overload, short circuit, incorrect connection and voltage transients.

Through the configuration of an internal selector switch, the unit could be paired to a particular battery type. Further, a temperature sensor could be configured to electronically compensate for temperature changes.

The charger was connected to an external caravan plug that was waterproofed and inset in the fuel door area.

### 5.2.7 Power Transmission and Distribution

To convey 144 V from the battery unit in the back of vehicle to the engine bay, high current low resistance power cable with orange insulation was used (see Appendix C.2).

This cable consisted of 50 mm<sup>2</sup> of copper conductor made up of very fine strands, resulting in a highly flexible power cable (Figure 32). It was double insulated (orange outer with white inner) for wearability and safety.

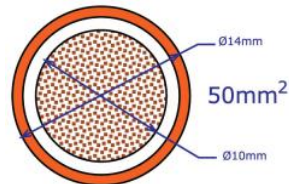

Figure 32: Cross section of Primary Distribution Cable

The cable had a maximum continuous rating of 150 Amps and was typically used with controllers rated 500 Amps or greater (such as the Curtis 1231C). It ran the length of the vehicle, from a cavity in the boot of the vehicle, under the chassis in the place of the original exhaust line to the internal emergency stop, to the engine bay.

### 5.2.8 Safety

There were a number of safety related components used to mitigate critical failures within the vehicle. These failures fell into two main categories:

1. A failure of motor, controller or control system that resulted in vehicle run-away.
2. An electrical short between the traction battery and earth line.

In the event of controller or motor run-away, a mechanical disconnect was installed to disconnect the motor and controller from the traction battery system and transmission line (Figure 33). This disconnection allowed service personnel to verify that components were isolated from the traction battery before commencing work. A key allowed only authorised personnel to engage power to test the vehicle.





**Figure 33: REV Eco Emergency Disconnect**

This mechanical system required operator intervention which were found to be slow, or fail to actuate altogether, in certain circumstances (such as driver error). For this reason and in order to mitigate Category 2 failures, a secondary fuse cut-off was also present. The Shawmut A50QS400-4, a fast blowing semiconductor fuse, sat in the primary transmission line between the mechanical disconnect and the traction battery. The 400A, 500V rated fuse could trip fast enough to protect the controller from excessive internal damage.

The present system is simplistic and does not adequately protect users and maintenance staff and requires further work before a redundant and safe system is achieved. A proposal for this design is outlined in the Appendix C.

### 5.3 Preparation and Installation

To prepare the car for the conversion, space had to be created for incoming components. The motor was then coupled to the existing transmission (Figure 34). A bar was mounted on the motor between the vibration dampeners. This bar then served as a framework for the mounting of engine bay components. A tachometer sensor was attached to the shortened axle side.



**Figure 34: Cleared Engine Bay with DC Motor installed.**

The primary conduit was installed beneath the vehicle and braced to the undercarriage. The conduit was fed from the spare wheel cavity to the front axle of the vehicle and fed into the engine bay. The battery cage was installed in the rear of the vehicle and batteries, fuses, battery charger and BMS installed.

The fuel cap was removed and replaced with a waterproof 240 V AC plug with a micro-switch sensor to detect the presence of a charging / extension cable (Figure 35). The emergency stop was installed into the lower dash and the main contactor installed into a bracket in the engine bay.



**Figure 35: Charging cable connected to Recharging plug in fuel door.**

The radio was removed from the centre console and repositioned under the passenger seat. A number of communication lines (Serial and Ethernet) were run from this position to the Eyebot controller, positioned in the original radio location (Figure 36). A GPS unit was installed and appropriate signal lines from the existing MCU and dash were replicated and connected to the Eyebot controller.



**Figure 36: Installed Eyebot configuration on dash**

Signal lines from the Eyebot were run to sensors around the vehicle and to the primary micro-switch. The micro-switch was wired to the primary contactor between the controller and battery.

The brake pump was mounted and connected to a secondary vacuum chamber, which in turn was connected to the original brake booster. The power steering unit was installed and connected to the existing power-steering fluid lines. The air conditioning unit was mounted securely to the right of the engine bay.

A 12 V DC bus was installed at the top of the engine bay and connected to the 12 V auxiliary appliances. A DC-DC converter was installed parallel to the motor-controller and primary contactor and connected to the 12V lead acid battery.

## 5.4 Topology

The complete system topology is presented in Figure 37. The diagram shows the interconnections between 144 V elements and the main traction battery.

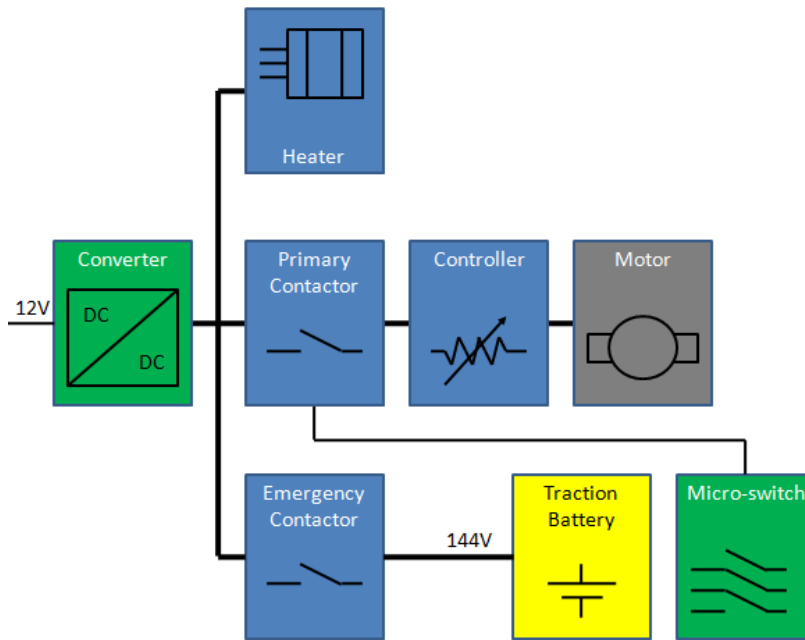

Figure 37: Overall System Topology

# 6 Auxiliary Systems

---

Within the vehicle's rolling architecture there existed a number of auxiliary sub-systems that assisted vehicle control and occupant comfort. This chapter discusses the adaptation of these systems for electric drive in the REV Eco.

## 6.1 Instrumentation and Control

A typical vehicle needs to provide the driver with some standard metrics such as speed, status of fuel and rpm. REV vehicles were required to further this by providing information on various vehicle components for research and benchmarking. This information will be used in future to:

- Provide the driver with advanced metrics.
- Enhance the quality of the drive.
- Provide detailed history on the operation of the vehicle and its components.

The system will, in future, be capable of:

- Providing driver/occupants with advanced control of vehicle hardware.
- Providing auxiliary "intelligent" systems (e.g. climate control).

### 6.1.1 Controller

The system was centred around a controller which took in a number of digital and analogue inputs from car sensors. The metrics were processed mathematically where required and displayed a summary on a screen. Where needed, metrics could be stored on a USB thumb drive for removal from the vehicle for benchmarking / analysis.

The controller was realized by the Eyebot Mk 6, a multi-purpose Linux based on-board controller developed for robotic applications (Figure 38). The controller utilized a low profile Gumstix computer which piggy-backed onto an accessories board which provided Bluetooth, Network, USB and serial connectivity in a low cost, open source control solution.



Figure 38: Eyebot Mk 6 Controller

The Eyebot utilised its touch screen for user interaction. In future the system may utilise voice recognition to operate.

The unit provided:

- Graphical display of vehicle warnings
- Critical error resolution
- GPS position and navigation
- Vehicle and trip metrics
- Speed, RPM and fuel gauge information

## 6.2 Accessories

The vehicle needed to provide a set of auxiliary services to:

- Increase passenger comfort
- Increase the ease of operation of the vehicle.

A topology of the accessories rail is presented in Figure 39. Further discussion of the components can be found in the sections below.

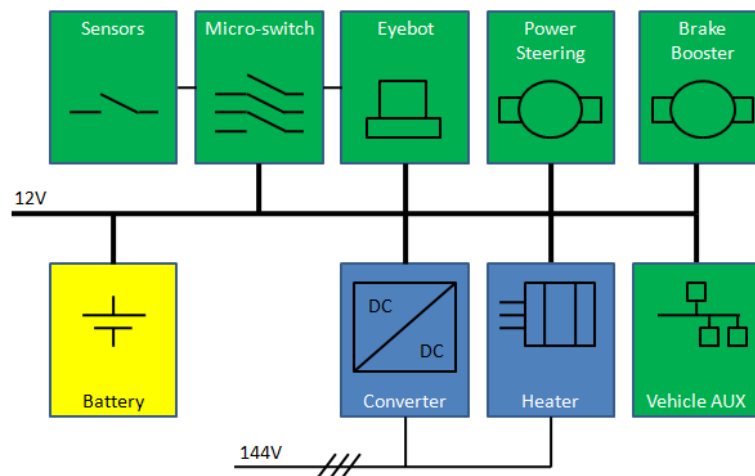

Figure 39: Topology of the Accessories Rail

### 6.2.1 Auxiliary 12V DC Systems

In order to power auxiliary services, a source of power was required. To reduce cost and complexity, the original battery and electrical systems were maintained.

The auxiliary battery was the power source for various vehicle subsystems and control logic. The battery used was a standard 12 V, 400 AH lead acid car battery.

At a future date these could be replaced by Thunder-sky Lithium Ion batteries similar to those that provide traction power – their higher energy density would decrease the load on the traction battery, however, this would require a battery management utility as discussed in Section 5.2.5.

## 6.2.2 DC-DC Converter

In normal service the vehicle's engine-driven alternator powered the electrical systems and recharged the battery. This was not a practical alternative for the electric vehicle: powering the DC system using the traction motor as a generator would have resulted in a number of losses in efficiency and would have required an array of moving components (requiring service).

It made more sense to recharge the auxiliary battery from the traction battery. Two options were presented:

1. System voltage (150V) could be used to supply a 12 V rail by passing through a DC-DC converter. The Iota DLS-55 is a compact and efficient converter that is capable of outputting a dual voltage: 14.2 V during vehicle use and 13.6V when the vehicle was off. The unit could provide 55 Amps and could be used for charging applications.
2. A high frequency battery charger modified to operate from DC voltages could be used to charge the auxiliary battery. The NG1 12-50 is a smaller version of the NG3 (see Section 5.2.6). The unit is microprocessor controlled, internally protected against overload, short circuit and incorrect connection and is capable of charging batteries up to 650AH. The unit could provide 60 Amps.

In selecting between the two options, the primary factor was charging efficiency. However, manufacturers are unclear about these figures as they have been shown to vary from application to application. The NG1 is regarded to be a more efficient unit (>85% efficiency vs. >80% of the Iota).

The NG1 is a specialised battery charger with features such as alarm, visual indicators and some limited thermal compensation features. However, during operation the NG1 failed to provide sufficient current to assist the auxiliary battery in powering subsystems – in most cases this led to a flat battery and failure to start the vehicle. For this reason the Iota was selected for implementation into the Eco REV as the DC converter and auxiliary battery charger.

It is important that the DC system draw no more than 60 Amps continuously during operation. Failure to meet this limitation will result in damage to the auxiliary battery and prolonged use can result in damage to the DC-DC converter.

## 6.2.3 12V DC Rail

A variety of onboard equipment (including auxiliary systems, sensors and devices) utilised 12 V power. Since the Eco REV will be used to facilitate a lot of future research into vehicle technologies, it's likely that future projects will need similar supply sources. To accommodate this a central bus providing 12 V was required.

The unit provided two rails:

**Always On Rail:** For devices such as the Eyebot controller that required permanent power, even while the vehicle is switched off.

**Auxiliary Rail:** For devices that needed only operate when the vehicle was switched on, this was typical of existing systems within the vehicle.

Additionally the bus provided a set of fuses to prevent over-current and minimised the damage of short circuiting.

Any 5 V devices were run through an internal 12 V - 5 V voltage regulator capable of driving the appropriate load.

#### 6.2.4 Heating

Heating an area the size of a vehicle cabin required a significant power source. Additionally it required a control system to ensure that the element was safely and efficiently operated.

The heating element (Figure 40) was configured in parallel to the traction motor and controller and could access the full 144 V of the traction motor. The heating system was controlled using the 12 V auxiliary supply which operated a 200 V relay.

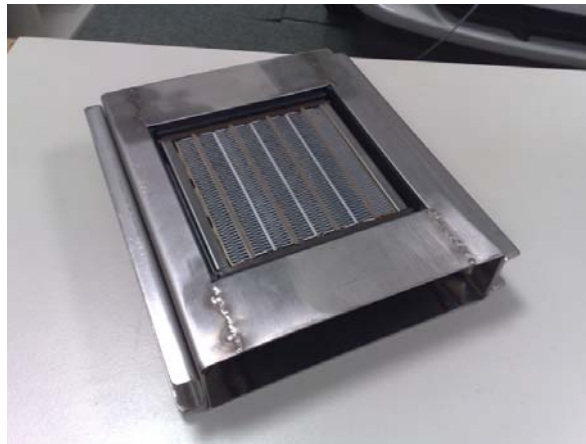

Figure 40: Heating Element in custom housing

The 12 control signal was set by a number of inputs:

**A user operated switch on the dashboard:** The interface for turning the heating system on/off. The switch contained a light which indicated if the control signal was active and high (implying element was on). It was important to note that an activated switch (down position) did not mean that the heating element was active. The relay signal could be disabled due to the presence of the following safety signals:

**A signal from the blower control switch:** Air passing through the heater element served as a transmission mechanism of heat, but in doing so, cooled the element. An element that was hot while the blower was off could cause overheating, damaging of surrounding plastic housing and had the risk of causing internal fire. A 12V relay was used with existing signal lines that ran to the blower multi-stage switch to provide a control signal.

**A signal from the vent door configuration:** The vent door configuration distributed air from the mixer to different vent locations in the vehicle. A mixer vent door also divided the proportion of cold air from the air-conditioning and hot

air from the heater. The mixer could constrict air flow to the element, even with the blower at maximum capacity. A reed sensor was installed into the mechanism to detect the appropriate vent door positions.

**A signal from a thermal cut-off on the element:** The heater core housed a PTC heating element – a self regulating core which established itself at 240 °C. Temperatures this high were safe for the surrounding plastic. As a safety measure, and to ensure the comfort of the passengers, the element was restricted to 100 °C using a thermal cut-off mounted onto the element.

**A signal from ignition switch position:** The power for the control signal was provided from the 12 V DC Rail which in turn was activated by a signal from the ignition switch. This ensured that the element was not armed when a user had left the vehicle.

The signals were connected in series logic - all signals needed to be armed in order for the element relay to activate.

The control signal armed a SSRDC (SPST 200 V 40 A) relay which connected the traction battery to the heating element. The element was comprised of multiple cells configured in a parallel configuration (Figure 41).

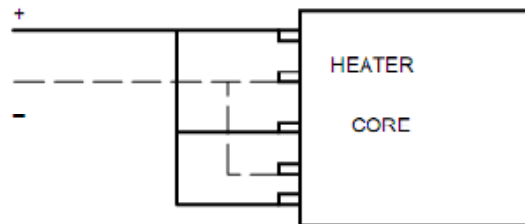

Figure 41: Heater Core Pin-out

The element drew 5 A and provided heated air at 45 °C with the blower actuated.

### 6.2.5 Air-conditioning

Due to time constraints and supply delays, the vehicle did not have working air-conditioning at time of licencing.

The existing air-conditioning system utilised a 2 kW compressor driven by a belt to the engine crankshaft. There were a number of problems associated with this configuration:

- The crankshaft of the electric motor was not long enough to drive a belt.
- The crankshaft was not constantly turning, so air-conditioning was only effective in gear.
- The present unit consumed a substantial amount of power.
- There were mechanical losses in driving a motor in this manner.

There were two potential solutions:



**Utilising a compact industrial electric motor:** The motor would drive the existing compressor through a belt and gearing system. The vehicles condenser, receiver-drier, thermostatic expansion valve and evaporator were left in place and would be utilised without change.

**Utilising an industrial refrigeration unit:** The unit would contain a high efficiency compressor powered through a refrigeration controller. Typically expensive, these would provide an efficient, compact and modular solution. The controller would additionally require AC voltage and require an inverter of sufficient capacity to power the device.

At present, inverters of sufficient capacity are prohibitively large and expensive to utilise in the vehicle. It was likely that both solutions would be needed to utilise the 144 V DC voltage provided by the traction battery, to provide sufficient power for air-conditioning.

### 6.2.6 Power-Steering

The power steering unit comprised of a rotary vane pump driven by the combustion engine through a belt and pulley system. The pump pressurised flow from the return line and provided the fluid to the power steering rotary valve at high pressure.

Electrical power steering solutions are present but were be expensive and supply was limited internationally. Since the power steering pumps were modular, a 12 V electric power-steering pump from an alternative vehicle was used and mated to the existing fluid lines.

### 6.2.7 Vacuum Brake Assist

The braking mechanism on ICE powered vehicles was vacuum assisted using pressure generated from the combustion process. Since this source of pressure no longer exists, an electric pump was required to maintain a vacuum.

The pump was mounted in the engine bay and powered from the 12 V DC Rail. The system was not powered when the auxiliary was switched off, which reduced the power dissipation of the vehicle while it was not being used.

In order to provide a source of pressure in the event of pump failure, an auxiliary vacuum chamber was installed into the engine bay. The chamber provided a vacuum storage volume sufficient to assist five to six actuations of the brake. The internal brake booster chamber additionally provided another two to three assisted actuations in the event of chamber failure.

The pump was actuated by a simple control system utilising two mercury pressure switches.

**The main pressure sensor:** Kept the vacuum pressure in the system at a stable level (13 inches). When the pressure fell below this level, the pump would actuate on a timer circuit (for a predefined time) to bring the pressure down.

**The failure sensor:** The switch provided a failure signals to the Eyebot when the pressure fell below a certain level (three inches).

The Eyebot conveyed error signals to the dash. As a legal requirement, the vehicle instrumentation was required to test warning lights, specifically the brake failure, to ensure that driver warnings were not masked by instrumentation (bulb) failure (ADR 2006). The existing car computer already performed this test.

# 7 Methods

---

In this chapter we attempted to model the car's behaviour based on relationships derived from electrical and mechanical theory. Benchmarking the vehicle was not possible due to the late completion of the vehicle and time constraints.

The model is inclusive of all major factors that acted on the vehicle. It was primarily designed to estimate range and provide a simple assessment of optimum gear configuration for reduced cost and range. It does not include a modelling of regenerative braking systems.

The model will accept a variety of vehicle and component parameters. In Section 7.1 we will introduce the various relationships and their variables. Section 7.2 will define the values used to model of the commuter vehicle.

## 7.1 Model

The model was developed in Microsoft Excel 2007 and accepted metric inputs on main vehicle attributes. It drew from previous work on EV performance modelling (Halstead 2006; Rick 2005).

The model is available in Excel 2003/05 as well as Excel 2007 format and can be found in the included disk media as EVModel.xls and EVModel.xlsx respectively.

### 7.1.1 Vehicle

The force required to overcome opposing forces is the force that the motor had to impart to the vehicle to keep it moving at speed.

For the purposes of modelling a typical vehicle we considered:

**Rolling Resistance:** Resistance associated with the contact between tyre and road.

**Brake and Steering Resistance:** Resistance associated with contact of braking and steering systems with the traction system.

**Aerodynamic forces:** Resistance associated with the drag due to travelling through air and into wind.

**Inclination forces:** Forces associated with the effect of gravity acting on the vehicle on an incline.

The total opposing forces can then be written as:

$$F_{Opp} = F_{rr} + F_{bs} + F_{drag} + F_{incline}$$

Where:

- $F_{rr}$  is the rolling resistance of the vehicle in N.
- $F_{bs}$  is the brake and steering resistance of the vehicle in N.
- $F_{drag}$  is the aerodynamic drag of the vehicle in N.
- $F_{incline}$  is the incline (hill) force of the vehicle in N.

The rolling resistance is defined as:

$$F_{rr} = C_{rr} \cdot N$$

Where:

- $C_{rr}$  is the dimensionless rolling resistance coefficient of the vehicle.
- $N$  is the normal force of the vehicle in N.

Expanded, this can be re-written as:

$$F_{rr} = C_{rr} \cdot m \cdot g \cdot \cos(\theta)$$

Where:

- $m$  is the mass of the vehicle in kg.
- $g$  is the gravitational acceleration.
- $\theta$  is the angle of inclination.

The rolling resistance coefficient,  $C_{rr}$  can be estimated as a constant, however for lower speeds the co-efficient behaves linearly (Brant 1993) and can be represented by:

$$C_{rr} = C_r \left(1 + \frac{V}{100}\right)$$

Where:

- $C_r$  is approximately 0.015 on hard surface (concrete), 0.08 on a medium hard surface and 0.30 on a soft surface such as sand.
- $V$  is the speed in mph of the vehicle.

There must then be some minimum rolling resistance coefficient,  $C_{r,min}$  for a vehicle at rest. Additionally, rolling resistances of tyres rated by manufacturers for a specific speed. The relationship between rolling resistance and velocity can then be written as:

$$C_{rr} = C_{r,min} + (C_{r,rated} - C_{r,min}) * \frac{v}{v_{rated}}$$

Where:

- $C_{r,min}$  is the minimum rolling resistance for the vehicle (rolling resistance when *just* about to move).
- $C_{r,rated}$  is the manufacturer specified rolling resistance.

- $v$  is the speed of the vehicle in m/s.  
 $v_{\text{rated}}$  is the speed corresponding to the rated rolling resistance in m/s.

Similarly, the brake/steering resistance is defined as:

$$F_{bs} = C_{bs} \cdot m \cdot g$$

Where:

- $C_{bs}$  is the dimensionless braking/steering resistance coefficient of the vehicle.

The magnitude of the aerodynamic force on the vehicle (also known as drag) can be calculated from:

$$F_{drag} = F_{drag,air} + F_{drag,rw}$$

$$F_{drag,air} = \frac{1}{2} \cdot \rho \cdot v^2 \cdot A \cdot C_d$$

Where:

- $\rho$  is the density of the fluid medium, in this case air at standard atmospheric pressure.  
 $v$  is the velocity of the vehicle through the medium in m/s.  
 $A$  is the frontal area of the vehicle in  $m^2$ .  
 $C_d$  is the dimensionless co-efficient of drag for the vehicle.

Similarly,

$$F_{drag,rw} = \frac{1}{2} \cdot \rho \cdot v_{rw}^2 \cdot A_{incident} \cdot C_{d,incident}$$

Where:

- $v_{rw}$  is the wind speed relative to the vehicle direction in m/s.  
 $A_{incident}$  is the proportion of surface area of the vehicle the wind strikes.  
 $C_{d,incident}$  is the co-efficient of drag on the incident surface.

The angle of incidence ( $\phi$ ) of the wind on the vehicle affects  $v_{rw}$ . We considered two cases:

**Headwind:** Wind that strikes the vehicle with ( $-90 < \phi < 90$ ). Acts in a manner which opposes motion on the vehicles frontal surface area ( $A$ ) and with the defined co-efficient of drag ( $C_d$ ).

**Tailwind:** Wind that strikes the vehicle with ( $-90 > \phi > -180$  and  $180 > \phi > 90$ ) which speeds the car up and acts on the vehicle's rear surface area ( $A_{\text{rear}}$ ) and with the co-efficient of drag ( $C_{d, \text{rear}}$ ).

That is to say, we only considered the forces acting in parallel to the direction of vehicle motion as these had the greatest effect on a vehicles range. The component of wind speed ( $v_{wind}$ ) which struck (A) or ( $A_{rear}$ ) was related to ( $\phi$ ) such that:

$$v_{rw} = v_{wind} \cdot \cos(\phi)$$

The forces associated with wind striking the vehicle in a direction perpendicular to the motion of the vehicle were shown to affect the form drag, interference drag, skin resistance and rolling resistance but was considered negligible for the purposes of this analysis.

Finally, the component of gravitational force which acted on the vehicle as it ascended or descended an incline was given by:

$$F_{incline} = m \cdot g \cdot \cos(\theta)$$

### 7.1.2 Wheels

Since drag is the force which had to be overcome in order for the vehicle to move, it was useful to know how much torque needed to be exerted by the wheels to move the vehicle.

$$\tau_{wheels} = F_{opp} \times r$$

Where:

- $\tau_{wheels}$  is the torque required at the wheels in Nm.
- $r$  is the radius of wheel (position of the force with respect to the fulcrum).

A figure of merit, the power in kW expended at the wheels was:

$$P_{wheels} = \frac{\tau_{wheels} \times 2\pi \times rpm}{60000}$$

### 7.1.3 Transmission

An automobile uses gear ratios in both the transmission and the drive axle to multiply power. The two ratios multiplied together equal the motor to wheel ratio.

$$R_{mw} = R_{gear} \cdot R_{finaldrive}$$

The motor to wheel ratio is the relationship that defines the number of turns of the motor for a single turn of the wheel. This gearing ratio was our torque multiplier:

$$\tau_{wheels} = \tau_{motor} \cdot R_{mw}$$

### 7.1.4 Motor

We rewrote this formula, accounting for the losses that took place in the transmission and drive system:

$$\tau_{motor} = \frac{\tau_{wheels}}{R_{mw} \cdot E_{drive}}$$

Where:

- $E_{drive}$  is the efficiency of the drive and traction system.
- $R_{mw}$  is the motor to wheel drive ratio.

It was assumed in the model that the losses at the wheels of the vehicle (in friction and sliding) were negligible when compared to other losses in the transmission and so was factored into the drive efficiency.

Similarly the motor rpm can be calculated by:

$$rpm_{motor} = 60 \cdot K \cdot v \cdot R_{mw}$$

Where:

- $K$  is the number of revolutions of the wheel per meter.
- $v$  is the velocity of the vehicle in m/s.

#### 7.1.4.1 Experimental Modelling

The relationship between current and torque and that between voltage, torque and RPM was complex and varied depending on motor characteristics. Two relationships were held:

$$\tau = k \cdot I^n$$

This can be re-written in terms of current as:

$$I = \left(\frac{\tau}{k}\right)^{\frac{1}{n}}$$

Where:

- $\tau$  is the motor torque in lb-ft.
- $k, n$  are dimensionless experimental parameters.
- $I$  is the motor current in Amps.

and,

$$V = \frac{d \cdot rpm}{\tau^b + c}$$

Where,

- $V$  is the motor voltage in volts.
- $rpm$  is the motor rpm.
- $\tau$  is the motor torque in lb-ft.
- $a, b, c, d$  are experimental parameters.

The motor parameters  $a$ ,  $b$ ,  $c$ ,  $d$ ,  $k$  and  $n$  were based on the experimental analysis of the ADC FB-4001 (Rick 2005). The parameters captured the motor behaviour under load (motor torque and current curves) in a mathematical relationship.

The electrical power drawn by the motor was then:

$$P_{motor} = V_{motor} \cdot I_{motor}$$

But since the motor was regulated with a lossy controller, we needed to account for the efficiency of the controller:

$$P_{motor} = \frac{V_{motor} \cdot I_{motor}}{E_{controller}}$$

Where:

$E_{controller}$  is the efficiency of the motor regulating controller.

The power drawn from the motor was equal to the power output from the battery:

$$P_{motor} = P_{battery}$$

### 7.1.5 Battery

The total power drawn from the battery was comprised of the power provided to the system plus power lost in internal dissipation.

$$P_{battery} = P_{system} + P_{internal\_disp}$$

$$P_{battery} = V_{system} \cdot I + R_{array} \cdot I^2$$

$$R_{array} \cdot I^2 + V_{system} \cdot I = P_{battery}$$

Finally, using the solution to the quadratic equation

$$I = \frac{-V_{system} - \sqrt{V_{system}^2 - 4 \cdot R_{array} \cdot P_{battery}}}{2 \cdot R_{array}}$$

Where:

$I$  is the battery current.

$R_{array}$  is the total array resistance.

$V_{system}$  is the total system voltage.

Once battery current ( $I$ ) was known the battery voltage ( $V$ ) was given by:

$$V = P_{battery}/I$$



To calculate the total array resistance, we needed to calculate the number of cells in the array. The number of batteries required depended on the system voltage and the voltage of individual cells, as well as the configuration of the batteries as defined by the following relationship:

$$N_{bat} = \frac{V_{system}}{V_{cell}} * S$$

Where:

- $N_{bat}$  is the number of batteries in the system.
- $V_{system}$  is the total system voltage.
- $V_{cell}$  is the voltage of the battery cell
- $S$  is the number of battery chains

Once the number of batteries was known, the internal resistance for the battery array was derived:

$$\frac{1}{R_{array}} = \frac{S}{R_{str}}$$

with

$$R_{str} = R_{cell} \cdot \frac{N_{bat}}{S}$$

Where:

- $R_{array}$  is the total array resistance.
- $R_{cell}$  is the resistance of each cell
- $R_{str}$  is the resistance of each string

### 7.1.6 Range

To estimate the range of the vehicle, we required an analysis of the SOC of the lithium battery array. Peukert's law was applied due to its relative simplicity and accuracy (Doerffel & Sharkh 2006). The law expressed the capacity of a lead-acid battery in terms of its discharge rate (Peukert 1897).

The product of velocity and the discharge time provided the distance covered by the vehicle:

$$d = \frac{C_p}{I^k} \cdot v$$

Where,

- $d$  is the range in km/h.
- $C_p$  is Peukert's Capacity of the array.
- $K$  is Peukert's Exponent for a Lithium Ion Cell
- $v$  is the speed of the vehicle in km/h.

It was important to note that this distance was attributed to a vehicle that started in motion at velocity  $v$  and remained at a constant speed in a straight path until the battery was fully discharged. It did not account for acceleration or braking, nor any external influences that opposed the motion of the vehicle not already discussed. It was to be considered a theoretical maximum under the best case scenario.

## 7.2 REV Eco

The follow sections account for the figures used in the formulas discussed which pertain to the vehicle characteristics.

### 7.2.1 Vehicle

The Getz was modelled on a based on a non-aerodynamic, front wheel drive, small car.

**Drag Coefficient ( $C_d$ ):** 0.33

The figure was estimated based on aerodynamic characteristics of similar vehicles. In addition, Eco REV will receive an under plate to improve its aerodynamic characteristics. In future the drag coefficient could be calculated from a "roll down" test, where the time (or distance) taken for a vehicle to come to stop from a given speed could be used to calculate  $C_d$  (Rutman 2007). Unofficial figures for the Hyundai Getz were around 0.33 (Cordes 2008), however the value is in line with both figures from similar models (Honda Civic Type R – 0.33, Toyota MR2 – 0.35, Toyota Prius – 0.26) and for typical small cars (around 0.35) and thus considered reliable (Brant 1993; Rick 2005).

**Frontal Area ( $m^2$ ):** 2.49 (CarToday 2006)  
**Initial Curb Weight (kg):** 1097 (Manufacturer Specification)

Figures were modelled for minimum passenger loads (driver and no luggage).

**Drive Efficiency Factor:** 0.91

The drive efficiency factor was estimated based on approximate values from models such as the Hyundai Tiburon, Honda Insight and Ford F250.

**Gear Ratios:**  
 1<sup>st</sup> Gear – 3.615 (Manufacturer Specification)  
 2<sup>nd</sup> Gear – 1.950  
 3<sup>rd</sup> Gear – 1.296  
 4<sup>th</sup> Gear – 1.061  
 5<sup>th</sup> Gear – 0.939

### 7.2.2 Motor

**Voltage (V):** 144V (Manufacturer Specification)  
**Weight (kg):** 65 (Manufacturer Specification)  
**Horse Power (hp):** 28.5 (Manufacturer Specification)  
**Maximum RPM (rpm):** 7000 (Manufacturer Specification)

Experimental Parameters:

**Motor A:** 46264 (Rick 2005)  
**Motor B:** 0.907 (Rick 2005)  
**Motor C:** 2068 (Rick 2005)

<b>Motor D:</b>	120	(Rick 2005)
<b>Motor N:</b>	1.55	(Rick 2005)
<b>Motor K:</b>	0.0085	(Rick 2005)

### 7.2.3 Battery

<b>Voltage (V):</b>	3.6	(Manufacturer Specification)
<b>Max. Weight (kg):</b>	3.1	(Manufacturer Specification) <6.84>
<b>Peukert's Exponent:</b>	1.025	(Modelled)

These figures were derived from simulations (see Appendix B.2: Figure B.2-1 and Peukert's Modelling Spreadsheet *Peukert.xls* on Disk Media) to correspond with manufacturers discharge curves. The figure was a good approximation when compared to typical LFP batteries with Peukert's values of around 1.05 (Plug-In-Supply 2008). The result was calculated using three points of comparison from battery discharge curves (Manufacturer Specification) (90 A draw, 88 Ah), (45 A draw, 90 Ah), (30 A draw, 91 Ah) which was fit to Peukert's model for a trial-and-error value (Figure 42).

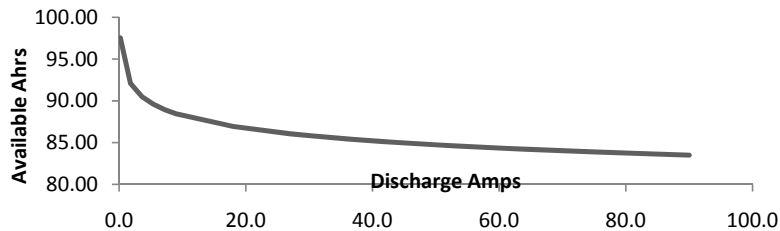

Figure 42: LFP90AHA Modelled as 94Ahr Battery with 1.025 Peukerts

<b>Battery Capacity:</b>	94Ahr (Modelled)
	90Ahr (Manufacturer Specification)

Because of chemical differences between lithium polymer and lead acid, the battery was modelled as a 94 Ahr unit with the Peukert's Exponent above to fit the data set.

<b>Discharge Current (Amps):</b>	27	(Manufacturer Specification)
<b>Peukert's Capacity (Amps):</b>	86.06	(Modelled)

The figure was modelled using maximum battery capacity of 94 Ah and 27 A standard discharge current draw with Peukert's Exponent above (Figure 42).

<b>Max. Resistance (Ohms):</b>	0.003	(Manufacturer Specification)
--------------------------------	-------	------------------------------

### 7.2.4 Controller

<b>Min. Voltage (V):</b>	96	(Manufacturer Specification)
<b>Max. Voltage (V):</b>	144	(Manufacturer Specification)
<b>Max. Current (Amps):</b>	500	(Manufacturer Specification)
<b>Weight (kg):</b>	11.2	(Manufacturer Specification)
<b>Efficiency Factor:</b>	0.95	(Manufacturer Specification)

## 7.2.5 Adjustments

<b>System Voltage (V):</b>	162	(Nominal)
<b>Battery Strings:</b>	1	
<b>Depth of Discharge (%):</b>	80	

Discharging a Lithium battery to its empty state could severely damage the battery and affect its performance characteristics. This in turn could adversely affect our analysis. To minimise damage, the battery was never discharged more than 80% between charges.

<b>Charger Weight (kg):</b>	5.5	(Manufacturer Specification)
<b>DC Converter Weight (kg):</b>	2.2	(Manufacturer Specification)
<b>Other Weights Removed (kg):</b>	230	(Manufacturer Specification)

Consisting of:

<b>Engine (kg)</b>	134	
<b>Radiator</b>	5	(Estimated)
<b>Fuel Tank (kg)</b>	14	
<b>Fuel (kg)</b>	45	
<b>Exhaust (kg)</b>	10	(Estimated)
<b>Alternator (kg)</b>	2	(Estimated)
<b>Power Steering Pump (kg)</b>	2	(Estimated)
<b>Spare Tyre (kg)</b>	15	(Estimated)
<b>Plastic Loss (kg)</b>	3	(Estimated)

<b>Other Weights Added (kg):</b>	55	
----------------------------------	----	--

Consisting of:

<b>Cable Weights (kg):</b>	10	(Estimated)
<b>Conduit Weights (kg):</b>	5	(Estimated)
<b>Fuses, Electronics (kg):</b>	5	(Estimated)
<b>Mounts and Braces (kg):</b>	25	(Estimated)
<b>Relays and Pumps (kg):</b>	10	(Estimated)

<b>Wind (N):</b>	0	
<b>Incline (factor):</b>	0.68	(Keuhs 2008)

Figures were modelled for typical Perth incline and no wind (Keuhs 2008).

<b>Tire Section (mm):</b>	175	(Manufacturer Specification)
<b>Tire Aspect (mm):</b>	65	(Manufacturer Specification)
<b>Tire Rim (inches):</b>	14	(Manufacturer Specification)
<b>Rolling Resistance (<math>C_{rr}</math>):</b>	0.011	(at 50km/h Manufacturer Specification)
<b>Brake/ Steer Resistance:</b>	0.003	(Estimated)

Figures assumed suitably inflated tires and a tuned braking system

<b>Electricity Kw/h Rate:</b>	0.11	
<b>Average Commute Distance:</b>	45 km	(Section 4.2.3 on Range)

# 8 Results and Analysis

---

The following sections present and discuss the results of the project including its tangible and theoretical components.

## 8.1 Workshop

The project was successful in establishing a workshop in the School of Electrical and Electronic Engineering. Although the workspace provided was adequate for our present development needs, a better solution is required due to continual team and development growth in the long term. Additionally:

- The workshop requires widening of the room doors to allow for easy vehicle removal – future vehicles will not fit this narrow clearance.
- Further space to hold developed vehicles is needed, since the workshop could only accommodate one vehicle at a time.
- The workshop requires organisation and needs to be fitted with additional storage and safety solutions.
- The workshop requires a secure wireless network with additional computing capabilities including software packages for modelling, simulation and PCB design.
- Further tools are needed primarily for wiring, insulation, waterproofing and drilling.
- Whiteboards and Noticeboards for team communication are required.

## 8.2 Solar Panel System

The solar panel system did not commence development this year. Consultations with a number of firms lead to a well defined analysis of what was required (Appendix D).

This component of the project was delayed due to a recent increase in demand for solar systems and a decreased supply of panelling systems. Also, the reluctance of contractors to work within stringent and inflexible university standards significantly delayed progress.

Research into the monitoring technology was conducted utilising the established solar system setup in the IDEAL House project.

The solar charging station component was looking to share or at least partially offset some of the costs of a larger installation with the University Environmental Services, and will do so, pending board approval.

### 8.3 Project Structure

The project had an established structure including:

- safety inductions
- team and technical meetings and presentations
- a method of division of labour

The project further needs:

- a means to track and assess student initiative
- a means to track the progress and quality of students practical work
- a reporting system to monitor bugs and develop a task list
- a documentation system to log and update present and past work

### 8.4 Website

The website was fully operational ([www.therevproject.com](http://www.therevproject.com)) and hosted a mission statement, objectives and goals, project history and regularly updated pictures of REV expos and events.

**Comment [P.S.1]:** If you're printing all this in colour, then why not make this look like a hyperlink like people are used to seeing URLs

In the nine month duration of the project, the site received 1374 hits and enlisted 28 members. Usage trends indicated that interest in the project, as measured by the number of unique visitors, was growing substantially (Figure 43).

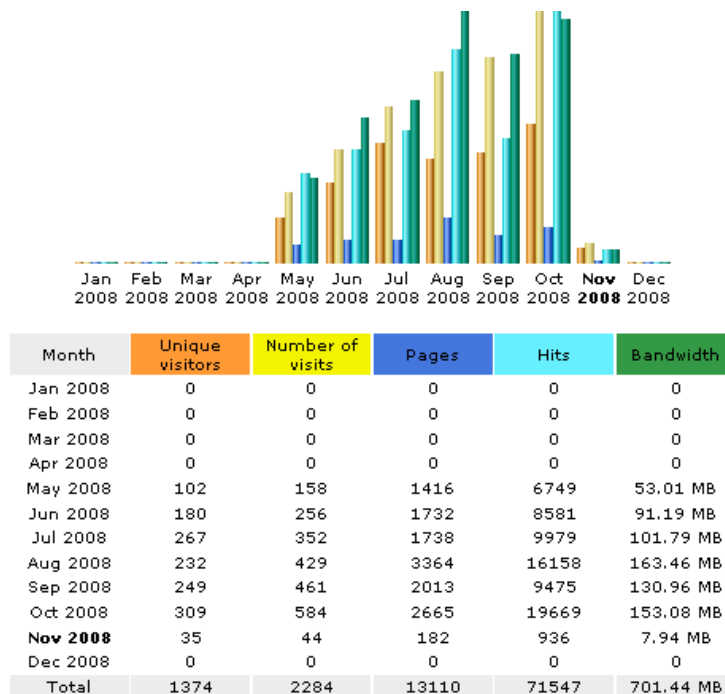

Figure 43: TheREVProject.com Usage Statistics as of 1<sup>st</sup> Nov 2008

The site additionally acted as a source of contact for a number of parties interested in sponsorship and could be a vital asset with further development in the future.

The energy monitoring system was developed but not implemented on the site. It is envisioned that the page will reside on the local EE web server and be linked to the REV website.

The site additionally needs to be upgraded to include a wiki for knowledge transfer and a blog containing up-to-date news and information regarding the project and the status of its deliverables.

## 8.5 Vehicle

The vehicle is in its finishing stages and has been successful in acquiring a restricted registration with a full registration pending some minor changes. The vehicle can now be driven using a standard C class manual licence on Australian public roads.

It will be displayed at a number of events after its public launch and will be ready for extensive benchmarking in Semester 1, 2009.

The following sections present the results derived from the theoretical analysis of the vehicle justified against real world measurements.

### 8.5.1 Weight and Distribution

The total mass of the vehicle was 1145.4 kg, approximately 48.4 kg heavier than its initial curb weight. There was significant capacity to reduce the weight of the vehicle using lighter materials, especially in the frame and chassis, as well as in the removal of unneeded components. The majority of this weight could be offset in commercial development because brackets and reinforcing structures could be built into the design.

The weight distribution however, changed significantly. The results are presented further in a colleague study by Ip, Tan and Wilson (2008; 2008; 2008). This new distribution was accommodated by a modified vehicle suspension and was not likely to significantly affect driving performance.

### 8.5.2 Opposing Force Analysis

Larger forces act on the vehicle at higher speeds (Figure 44). At these high speeds a significant component of opposing force was due to air drag and wind resistance. These forces were proportional to  $C_d$  the coefficient of drag of the vehicle, a parameter of the vehicle chassis design.

At lower speeds the rolling resistance of the vehicle was a significant component of the opposing force, and correlated to the type of tyres used on the vehicle.

For the purposes of analysis, drag contributed by opposing wind was considered negligible but was significant at high speed.

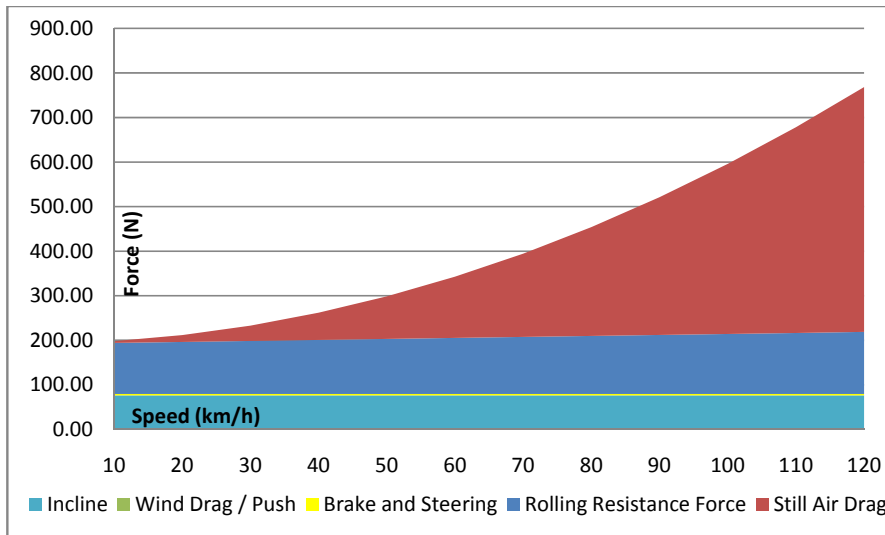

Figure 44: Total Opposing Forces acting on Eco

### 8.5.3 Range Analysis

Theoretical range analysis was based on the measurement of a vehicle starting at speed on a surface of zero incline, acted on and continuing unstopped until full discharge of the batteries and brought to a stop only by opposing forces above.

Since the rate of discharge directly affected the remaining capacity of the battery (Peukert's Law) and since forces opposing motion are low in magnitude at these speeds, we observed longer driving ranges at lower speeds.

Figure 45 illustrates the theoretical (blue) and probable (red) range of the vehicle from the developed model:

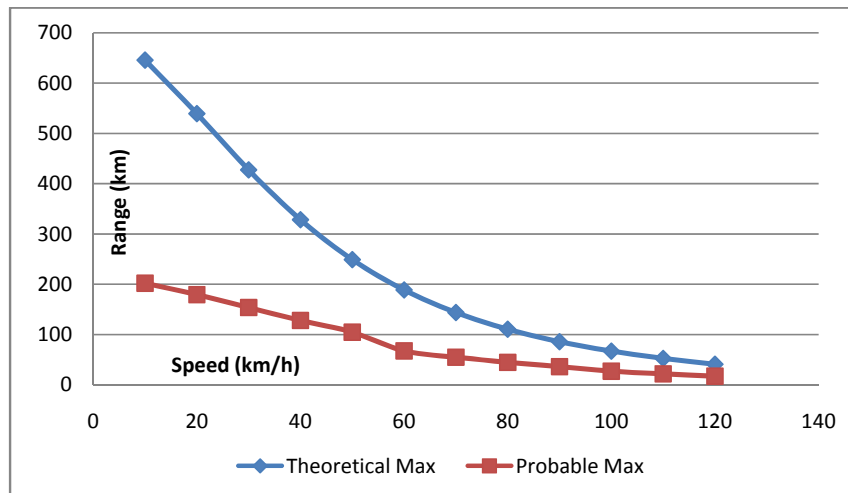

Figure 45: Theoretical vs. Probable Maximum Range



In typical city driving, vehicles accelerate and decelerate over short distances. Forces in acceleration added to the current draw from the traction battery. Braking will act as an opposing force over this distance.

Since trips rarely occur over distances with a zero degree incline, we also considered the effect of this incline on range. The average incline factor of Perth is 0.68 (Keuhs 2008).

Finally we needed to consider the maximum rated RPM of the motor and shift gears appropriately to avoid long term stress and damage. Gearing is described in more detail in Section 8.5.4.

At average city speeds (around 50 km/h) the vehicle was expected to have approximately a 104 km maximum range to full battery discharge. With correct battery treatment (80% DOD) the range was expected to be around 80 km.

### 8.5.4 Gear Analysis

An analysis of the gearing required for the REV Eco is shown in Table 2. We noted that fourth and fifth gears are not normally used because they restrict the operating range of the vehicle, but were available if extra power is necessary.

In actual driving, starting the vehicle in first gear was difficult because the torque at the wheels was too high to prevent wheel slipping. The vehicle needed to be started in second or third gear depending on road conditions.

The vehicle was always parked in first gear, because in neutral in the absence of a handbrake (due to human error), the vehicle may roll. Additionally, since there was no over-rev protection, pressing the accelerator in neutral (subjecting the motor to extremely high RPM for a prolonged duration) could have caused permanent damage to the drive motor.

Table 2: Gear Analysis of REV Eco

Gear Table	10	20	30	40	50	60	70	80	90	100	110	120
1st Gear	311	276	236	197	161	130	105	84	68	54	43	34
Motor RPM	1264	2527	3791	5055	6318	7582	8845	10109	11373	12636	13900	15164
2nd Gear	239	213	184	154	127	104	84	69	56	45	36	28
Motor RPM	682	1363	2045	2727	3408	4090	4771	5453	6135	6816	7498	8180
3rd Gear	206	185	160	135	112	92	76	62	51	42	33	26
Motor RPM	453	906	1359	1812	2265	2718	3171	3624	4077	4530	4983	5436
4th Gear	194	174	151	128	107	88	73	60	49	41	33	26
Motor RPM	371	742	1113	1484	1854	2225	2596	2967	3338	3709	4080	4451
5th Gear	187	168	146	124	104	86	72	59	49	40	33	26
Motor RPM	328	656	985	1313	1641	1969	2298	2626	2954	3282	3611	3939

### 8.5.5 Operating Cost Analysis

By following the optimum gear selection presented in Section 8.5.4 users of the vehicle will minimize the running cost. The trends show that operating the vehicle at higher speeds and higher gears increased the cost of the drive.

The operating cost of the vehicle over a commute distance of 45 km (see Section 4.2.3) for best, typical and worst case gearing are tabulated (Table 3). The cost analysis factors in green energy pricing, ongoing servicing and maintenance costs under responsible ownership of the vehicle (Synergy 2008).

**Table 3: Cost analysis for a 45km commute by avg. speed**

Cost Table	10	20	30	40	50	60	70	80	90	100	110	120
Best Case	\$0.22	\$0.24	\$0.27	\$0.32	\$0.39	\$0.47	\$0.57	\$0.69	\$0.83	\$0.99	\$1.17	\$1.38
Typical Case	\$0.22	\$0.24	\$0.27	\$0.41	\$0.49	\$0.58	\$0.70	\$0.83	\$1.06	\$1.24	\$1.43	\$1.63
Worst Case	\$0.35	\$0.39	\$0.43	\$0.50	\$0.59	\$0.69	\$0.81	\$0.95	\$1.10	\$1.27	\$1.45	\$1.65

In most cases a commuter could expect to pay \$0.49 for the 45km return trip which is considerably cheaper than public transport (Transperth 2008).

Over 7.5 years (the simulated lifespan of the battery) the main traction battery will approach end of life, requiring replacement. At this point replacement of the battery is functionally beneficial – aside from efficiency gains, it is likely that battery improvements that would have occurred in this in period could be utilised - meaning increased range and better performance characteristics when compared to the original vehicle.

Over two years (since its purchase) the depreciation on the original Thunder-sky battery pack was approximately \$4000. After 7.5 years the \$10000 battery pack was expected to cost around \$2000 to replace with an equivalent model (around \$250/year) or around \$10000 to replace with a mid range new model (around \$1000/year).

# 9 Discussion

---

With an operating range of 80 km, REV Eco was theoretically capable of achieving the requirements of a successful commuter vehicle and was more than sufficient for medium to long term commuter use.

The overall cost of conversion was estimated at around \$25,000 excluding labour. This was priced within the typical price bracket for vehicles of this class. With large scale manufacturing the price to the end user will be even lower. Discounting depreciation and life, the vehicle can compete against high end petrol and diesel models.

REV Eco was capable of achieving high efficiencies and better performance than conventional vehicles. Additionally, the system was easier to drive, requiring no clutch to change gears.

Future benchmarking runs are expected to verify the vehicle range, efficiency, top speed and acceleration characteristics with the later expected to significantly outperform that of the original ICE.

## 9.1 Drive

Initial tests found that the vehicle was comfortable and virtually silent to drive. These tests were performed at slow speed over a limited range.

There was some inherent danger, due to the lack of noise in the operation of the vehicle. At very slow speeds the vehicle controller made a high pitched whine (see Section 6.2.3) but at higher speeds the vehicle was difficult to hear approaching which posed a safety risk to pedestrians. It was expected that the limited noise made by the vehicle would be inaudible to the driver of another vehicle.

## 9.2 Model and Limitations

The model created a good foundation to assist in the design of a typical AC or DC EV. While the formulas presented are basic, the model presented probable estimates of range based on environmental factors.

Future work should verify the model and adapt it as needed.

A significant limitation of the model was its inability to accept acceleration values and examine the effect of this force on battery discharge and range. Additionally it would be desirable for cornering forces to be considered and for a user to be able to input the characteristics of a particular trip in stages, for the calculator to determine the performance of the car in a journey under these conditions.

### 9.3 Suggestions of Vehicle Improvement

A number of suggestions can be derived from the model for vehicle improvement.

**Reduction of Weight:** A reduction of weight can reduce the still air drag, rolling resistance and incline forces directly. Weight reduction can be achieved by using lighter weight materials for chassis as well as additional mounting, improved battery technology (lighter weight), removal of excess plastic, insulation and redundant components and reducing cabling lengths.

**Reduction of Drag Coefficient ( $C_d$ ):** A reduction of the drag co-efficient can reduce the still air drag and the drag from wind resistance. This can be achieved by changing the aerodynamic characteristics of the chassis. The following table (Brant 1993) outlines the components of the coefficient of drag for a typical 1970's vintage car:

Table 4: Breakdown of Drag contribution by Chassis Area (Brant 1993)

Car Area	$C_d$ Value	Percentage of total
Body-Rear	0.14	33.3
Wheel wells	0.09	21.4
Body-Under	0.06	14.3
Body-Front	0.05	11.9
Projections & Indentations	0.03	7.1
Engine compartment	0.025	6.0
Body-Skin friction	0.025	6.0
Total	0.42	100.0

While the coefficient of drag is relatively low for Eco, improvements could be made to lower the value further:

- **Body Rear:** The ideal chassis shape is typically that of a "falling raindrop" with a rocket nose and boat tail (Brant 1993). This is typically difficult to achieve and can have a negative effect on aesthetics.
- **Tyre and wheel well:** The area makes up a large proportion of the drag so small changes can have significant benefits (Brant 1993). Smooth wheel covers, thinner tyres, rear wheel well covers, removal of mud guards and lowering of vehicle height are suggested improvements. The installation of some of these can have a negative effect on aesthetics, reducing consumer demand.
- **Under-body:** Installation of an under plate to restrict airflow – as characteristic of the General Motor's EV1. It serves a dual role in protecting the vehicle from debris and water thrown up by the road. The plate has been designed but needs to be manufactured and installed.

**Safety System Improvement:** While the vehicle's present safety system is adequate for operational purposes, further improvements can mean safer isolated voltages, device isolation and electronically triggered shutdown.

**Onboard Computer Deprecation:** The combination of Eyebot and dash would be sufficient for the control and monitoring of the vehicle's subsystems. It would be useful to transition all existing vehicle computer control subroutines to the Eyebot for enhanced software control and monitoring.

## 9.4 Future Work

There is much future work required, aside from further research and improvement into battery technology a number of subsystems can be investigated further with a view to be improved:

**Battery management and balancing:** Improvements in battery management systems can lead to features such as individual cell monitoring and charging. Improvements in configuration can be expected with proposed future designs avoiding the "rats nest" wiring configuration in favour of a daisy chain type link. Development on a new type battery management system has commenced with senior workshop technician Ivan Neubonner producing first prototypes to be used with the Lotus EV.

**Battery and component configuration:** The layout and orientation of batteries and components in the vehicle to distribute load efficiently and increase interior space while ensuring occupant safety.

**Battery comparison:** The REV project and wider EV community would greatly benefit from some standardized comparison and independent benchmarking of EV battery technology including performance and physical characteristics, availability and price.

**Wireless charging:** A wireless charging system for electric vehicles would have significant benefit in future. The system would likely utilise some form of induction to convey charge over an air gap into the vehicle.

**Power payment system, green payment system:** The wireless charging technology, especially when interfaced with a registration and energy accounting system would allow vehicle charging without user intervention.

**Controller technology:** Is an area that requires much improvement. High quality, high performance controllers are difficult to obtain and prohibitively expensive. Research and development of a motor controller could have significant benefits in the performance of the vehicle and motor.

**Eyebot Control of Auxiliary Systems:** The Eyebot controller can easily be adapted to control auxiliary subsystems such as climate control, navigation, reversing aids, occupant safety and comfort.

# 10 Conclusions

---

It is possible to develop an environmentally sustainable and commercially viable means of transportation for the purposes of inter-city duties such as commuting.

The REV vehicle was shown to be able to meet the needs of 99% of Australian commuters for a lower initial capital cost when compared to similar vehicles of its class. Furthermore, it was capable of achieving and exceeding performance baseline requirements of a commuter vehicle, with an 80-100 km servicing range.

It was found that EV technology was highly efficient when compared with alternative fuels and energy carriers such as hydrogen. Further it decoupled the problem of sustainable power generation from the vehicle. The technology can easily be paired with solar power to become self-sustaining. Alternatively, in sourcing power from the grid, electric vehicles can seamlessly transition as the grid becomes more efficient and switches to renewable sources.

Electric vehicles are simpler in design and consequently cheaper to maintain and easier to operate. When combined with an intelligent control system, this work has shown that the result is capable of providing all the conveniences of a modern vehicle while serving as a platform for future automotive research.

# 11 Acknowledgements

---

I would formally like to acknowledge the work, support and direction of the following people without which the project would not have been possible:

**Assoc. Prof. Thomas Braünl** for his supervision, direction and support managing the team.

**Dr. Kamy Cheng** for his supervision and expertise on mechanical concepts.

Senior Workshop Technicians: **Ivan Neubonner** and **Ken Fogden** for countless hours of work on the vehicle, advice and creative direction.

**Steve Whitely** and members of the **REV Team** for their invaluable project work.

**Tuarn Brown, Ian Hooper, Rob Mason, Rod Dilkes** and **WAEVA** for their technical support, dedication to the EV cause and expertise.

**Pooja Subramanya** for her unconditional support and reassurance over many sleepless nights as well as many late nights proof reading herself.

**Rachel Butler, Jess Manea** and **Bindi Shah** for proof reading.

**Comment [P.S.2]:** Technically you should put rach, bindi and jess in this section too.

# 12 References

---

- ABS 2007, *Survey of Motor Vehicle Use* Australian Bureau of Statistics.
- Abusleme, A., Dixon, J. & Soto, D. 2003, 'Improved performance of a battery powered electric car, using photovoltaic cells', in *Power Tech Conference Proceedings, 2003 IEEE Bologna*, ed. J. Dixon, p. 6 pp. Vol.3.
- Adcock, P., Crewe, C. M., Grange, N. & Passmore, M. A. A. P. M. A. 1993, 'Performance predictions for a single seater junior formula electric racing car', in *Systems for Electric Racing Vehicles, IEE Colloquium on*, ed. C. M. Crewe, pp. 8/1-8/7.
- ADR 2006, *Vehicle Standard (Australian Design Rule 35/00 – Commercial Vehicle Brake Systems)* in ADR 35/00, vol. ADR 35/00, Australian Government - Attorney-General's Department, Australia.
- Allen, T., Mellor, P. H., Monkhouse, P. J. & Howe, D. A. H. D. 1993, 'Assessment of battery technologies for electric vehicles', in *Systems for Electric Racing Vehicles, IEE Colloquium on*, ed. P. H. Mellor, pp. 7/1-7/5.
- Berman, B. & Gelb, G. H. 1974, 'Propulsion systems for electric cars', *Vehicular Technology, IEEE Transactions on*, vol. 23, no. 3, pp. 61-72.
- Berry, W. B., Bauer, P. H., Martin, R. A., McMullen, S. R. A. M. S. R. & Schneider, E. D. A. S. E. D. 1994, 'A race car, the formula lightning as an engineering education platform for enhancing the engineering development of the electric car between industry and university', in *Power Electronics in Transportation, 1994. Proceedings*, ed. P. H. Bauer, pp. 41-46.
- Blaabjerg, F., Consoli, A., Ferreira, J. A. & van Wyk, J. D. A. v. W. J. D. 2005, 'The future of electronic power Processing and conversion', *Power Electronics, IEEE Transactions on*, vol. 20, no. 3, pp. 715-720.
- Bourne, C. & Ball, R. 1993, 'A hybrid battery powered drivetrain for a high performance electric vehicle', in *Systems for Electric Racing Vehicles, IEE Colloquium on*, ed. R. Ball, pp. 4/1-4/3.
- Boyd, R. S. 2007, 'Hydrogen cars may be a long time coming', *McClatchy Newspapers*.
- Brant, B. 1993, *Build Your Own Electric Vehicle*, 1st edn, Published by McGraw-Hill Professional, 1994.
- Bruegmann, R. 2005, *Sprawl: A Compact History*, 1st edn, University of Chicago Press, Chicago.
- CarToday 2006, 'The number game', no. August 2006, pp. pp 102-106. [4 November 2006].
- Cooper, J. C. B. 2003, 'Price Elasticity of Demand for Crude Oil: Estimates for 23 Countries', *OPEC Review*, vol. Vol. 27, pp. pp 1-8.
- Cordes, R., *Index of vehicle drag co-efficients*, [4 Nov 2008].
- D'Agostino, S. 1993, 'The electric car', *Potentials, IEEE*, vol. 12, no. 1, pp. 28-32.
- Ding, Z., Zhao, D. & Zuo, J. 2007, 'Modeling and Simulation about an Electric Car's Regenerative Braking System', in *Mechatronics and Automation, 2007. ICMA 2007. International Conference on*, ed. D. Zhao, pp. 1705-1709.
- Doerffel, D. & Sharkh, S. A. 2006, 'A critical review of using the Peukert equation for determining the remaining capacity of lead-acid and lithium-ion batteries', *Journal of Power Sources*, vol. 155, pp. pp 395-400.
- Duany, A. P.-Z., Elizabeth 2001, *Suburban Nation: The Rise of Sprawl and the Decline of the American Dream*, 1st edn, North Point Press.
- Gringmuth, A. 1996, 'Electric vehicle components', in *Northcon/96*, p. 385.
- Gross, B., Sutherland, I. & Mooiweer, H. 2007, *Hydrogen fueling infrastructure assessment*, General Motors Research & Development Center.



- Gulhane, V., Tarambale, M. R. & Nerkar, Y. P. 2006, 'A Scope for the Research and Development Activities on Electric Vehicle Technology in Pune City', in *Electric and Hybrid Vehicles, 2006. ICEHV '06. IEEE Conference on*, ed. M. R. Tarambale, pp. 1-8.
- Halstead, J., *EVConvert.com*. Available from: <http://www.evconvert.com/> [19 October 2008].
- Harrison, M. & Fairhurst, P. 1993, 'Project Volta-towards an electric speed record', in *Systems for Electric Racing Vehicles, IEE Colloquium on*, ed. P. Fairhurst, pp. 9/1-9/5.
- Hirschorn, J. S. 2005, *Sprawl Kills - How Blandburbs Steal Your Time, Health, and Money*, Sterling & Ross, New York.
- Hooker, M. A. 2002, 'Are Oil Shocks Inflationary? Asymmetric and Nonlinear Specifications versus Changes in Regime', *Journal of Money, Credit and Banking*, vol. 34, no. 2.
- Hooper, I., *Zero Emission Vehicles Australia*. Available from: <http://www.zeva.com.au/>.
- Inslee, J. B. H. 2007, *Apollo's Fire*, Island Press, Washington, D.C.
- Jefferson, C. M. 1993, 'Power management in electric vehicles', in *Systems for Electric Racing Vehicles, IEE Colloquium on*, pp. 5/1-5/5.
- John, V. 2006, 'Electric Cars For Enlightened Stars', *Spectrum, IEEE*, vol. 43, no. 11, pp. 14-16.
- Johnson-Controls 2005, *Enhancing Interior Features, Functions and Performance*, Michigan.
- Joshi, R. P. & Deshmukh, A. P. 2006, 'Hybrid Electric Vehicles: The Next Generation Automobile Revolution', in *Electric and Hybrid Vehicles, 2006. ICEHV '06. IEEE Conference on*, ed. A. P. Deshmukh, pp. 1-6.
- Keuhs, J. 2008, *Re: Perth GEO Information*, R. Mathew, Perth, Australia.
- Kuchta, R. & Varba, R. 2003, 'Measuring and monitoring system for electric cars', in *Diagnostics for Electric Machines, Power Electronics and Drives, 2003. SDEMPED 2003. 4th IEEE International Symposium on*, ed. R. Vrba, pp. 342-344.
- Lukic, S. M. & Emadi, A. 2002, 'Performance analysis of automotive power systems: effects of power electronic intensive loads and electrically-assisted propulsion systems', in *Vehicular Technology Conference, 2002. Proceedings. VTC 2002-Fall. 2002 IEEE 56th*, ed. A. Emadi, pp. 1835-1839 vol.3.
- Maggetto, G. & Van Mierlo, J. 2000, 'Electric and electric hybrid vehicle technology: a survey', in *Electric, Hybrid and Fuel Cell Vehicles (Ref. No. 2000/050), IEE Seminar*, ed. J. Van Mierlo, pp. 1/1-111.
- McQuin, N. P., Davis, A. J. & Rizzoni, G. 2006, 'Electrical Drive-Train Design for the Current Electric Land-Speed-Record Car', in *Power Electronics, Machines and Drives, 2006. The 3rd IET International Conference on*, ed. A. J. Davis, pp. 459-463.
- Miller, J. M., Emadi, A., Rajarathnam, A. V. & Ehsani, M. A. E. M. 1999, 'Current status and future trends in More Electric Car power systems', in *Vehicular Technology Conference, 1999 IEEE 49th*, ed. A. Emadi, pp. 1380-1384 vol.2.
- Monkhouse, P. J., Allen, T., Mellor, P. H. & Howe, D. A. H. D. 1993, 'An advanced drive-train for electric racing vehicles', in *Systems for Electric Racing Vehicles, IEE Colloquium on*, ed. T. Allen, pp. 6/1-6/4.
- Murray, G. O. & Ostrowski, G. J. 1981, 'Powering the electric car', in *Vehicular Technology Conference, 1981. 31st IEEE*, ed. G. J. Ostrowski, pp. 45-48.
- Olah, G. A., Goepfert, A., Prakash, G. K. S. & V.C.H, W. 2006, 'Beyond Oil and Gas: The Methanol Economy'.
- Olken, M. 2004, 'Distributing the load: distributed resources bring generation close to home', *Power and Energy Magazine, IEEE*, vol. 2, no. 3, pp. 4-6.
- Oman, H. 1994, 'New electric-vehicle batteries', in *Northcon/94 Conference Record*, pp. 326-330.
- Oman, H. 1999, 'Making batteries last longer [for electric vehicles]', *Aerospace and Electronic Systems Magazine, IEEE*, vol. 14, no. 9, pp. 19-21.
- Oman, H. 2002, 'Electric car progress', *Aerospace and Electronic Systems Magazine, IEEE*, vol. 17, no. 6, pp. 30-35.
- Oman, H. & Gross, S. 1995, 'Electric-vehicle batteries', *Aerospace and Electronic Systems Magazine, IEEE*, vol. 10, no. 2, pp. 29-35.
- Paine, C. 2006, *Who Killed the Electric Car?*, [Documentary], Sony Pictures Home Entertainment.
- Plug-In-Supply, *Plug-In Supply FAQ about LiFePO4 Batteries*. Available from: <http://www.pluginsupply.com/FAQ.htm> [4 November 2008].
- Plunkket 2008, *Automobile and Truck Statistics*.

- Richard, M. G. 2008, 'Lithium Iron Phosphate Breakthrough: Better Batteries for Hybrids and Electric Cars', *Treehugger.com*, 29 July 2008.
- Rick, U., 27 October 2005, *Electric Vehicle Calculator*. Available from: <http://www.geocities.com/hempev/EVCalculator.html> [19 October 2008].
- Rizzoni, G., Sinsheimer, B., Ponziani, K., Gorse, J. A. G. J., Davis, T. A. D. T., McQuin, N. A. M. N. & Miotti, A. A. M. A. 2005, 'Design, analysis and performance of an electric land speed record streamliner', in *Vehicle Power and Propulsion, 2005 IEEE Conference*, ed. B. Sinsheimer, pp. 445-449.
- Rutman, J. 2007, *How to do a Roll-down test*, Clausthal-Zellerfeld, Germany.
- Salihi, J. T. 1973, 'Energy Requirements for Electric Cars and Their Impact on Electric Power Generation and Distribution Systems', *Industry Applications, IEEE Transactions on*, vol. IA-9, no. 5, pp. 516-532.
- Sandalow, D. 2007, 'Ending Oil Dependence', *The Brookings Institution*.
- Schiffer, M. B. 2003, *Taking Charge: The Electric Automobile in America*, Smithsonian.
- Schwartz, H. J. 1977, 'The computer simulation of automobile use patterns for defining battery requirements for electric cars', *Vehicular Technology, IEEE Transactions on*, vol. 26, no. 2, pp. 118-122.
- Schwartz, R. 1980, 'Design and development of high-performance two-passenger electric automobile', in *Vehicular Technology Conference, 1980. 30th IEEE*, pp. 203-210.
- Sharma, V. K., Kamble, R. D. & Sharma, R. 2006, 'Control, Alarm and Indicator Systems in Modern Electric Vehicles', in *Electric and Hybrid Vehicles, 2006. ICEHV '06. IEEE Conference on*, ed. R. D. Kamble, pp. 1-5.
- Sinclair, P., Duke, R. & Round, S. 1998, 'An adaptive battery monitoring system for an electric vehicle', in *Power Electronic Drives and Energy Systems for Industrial Growth, 1998. Proceedings. 1998 International Conference on*, ed. R. Duke, pp. 786-791 Vol. 2.
- Stanley, J., Currie, G. & Stanley, J. 2007, 'The way to go?', *No Way to Go*, vol. 1, no. 1, pp. 16.1-16.11.
- Sulzberger, C. 2006, '100 miles on one charge', *Power and Energy Magazine, IEEE*, vol. 4, no. 6, pp. 68-70.
- Tesla 2007, *Twenty First Century Car Data*, Tesla Motors.
- Thomas, G. 2003, *Hydrogen Storage*, [Powerpoint Presentation], Sandia National Laboratories, [1st November 2008].
- USEPA 2008, *Inventory of U.S Greenhouse Gas Emissions and Sinks 1990-2006*, USEPA #430-R-08-005.
- Vezzini, A. & Reichert, K. 1996, 'Power electronics layout in a hybrid electric or electric vehicle drive system', in *Power Electronics in Transportation, 1996. IEEE*, ed. K. Reichert, pp. 57-63.
- Voelcker, J. 2007, 'Top 10 Tech Cars 2007', *Spectrum, IEEE*, vol. 44, no. 4, pp. 34-41.
- Wakefield, E. H. 1978, 'The electric phoenix an illustrated history of electric cars, motors, controllers, and batteries', in *Vehicular Technology Conference, 1978. 28th IEEE*, pp. 73-74.
- Wykes, F. C. 1993, 'Influence of electric vehicle racing formulae on electric competition vehicle systems', in *Systems for Electric Racing Vehicles, IEE Colloquium on*, pp. 311-313.
- Yerkes, J. W. 1994, 'Electric vehicle developments in Europe and Japan', in *Northcon/94 Conference Record*, pp. 254-259.
- Young, W. R., Jr. 1994, 'Electric vehicles of yesterday carry us into tomorrow', in *Southcon/94 Conference Record*, pp. 14-16.